

PORTIERI, A HELLENISTIC *FATTORIA* IN THE FOOTHILLS OF THE SIBARITIDE (CALABRIA, ITALY),  
SITE REPORT AND SHARD CATALOGUE

N. OOME & P.A.J. ATTEMA

*University of Groningen, Groningen Institute of Archaeology, Groningen, the Netherlands*

**ABSTRACT:** In the October 2004 campaign of the Raganello Archaeological Project (RAP) of the Groningen Institute of Archaeology (GIA), a survey team headed by the first author located the remains of a Hellenistic site in the foothills of the Sibaritide plain in northern Calabria (Italy). The size and nature of the artifact scatter that was mapped indicated a different type of site than the subsistence farms known so far from previous surveys. Study of the ceramics suggests that the storage of wine played a prominent role on the site. From this, it may be deduced that we are dealing with a site that specialized in viniculture and produced for the market of the Greek town of Thourioi, located in the plain at a distance of 20 km. Through the ceramics, the Portieri site can be dated in the period from approximately mid 4<sup>th</sup> until mid 3<sup>rd</sup> century BC (c. 350-250 BC).

**KEYWORDS:** southern Italy, Sibaritide, Raganello Archaeological Project, Hellenistic settlement patterns, Hellenistic *Fattoria*, survey, Hellenistic amphorae

## 1. INTRODUCTION

In the October 2004 survey of the Raganello Archaeological Project (RAP) of the Groningen Institute of Archaeology (GIA) a large concentration of shards dating to the Hellenistic period was found

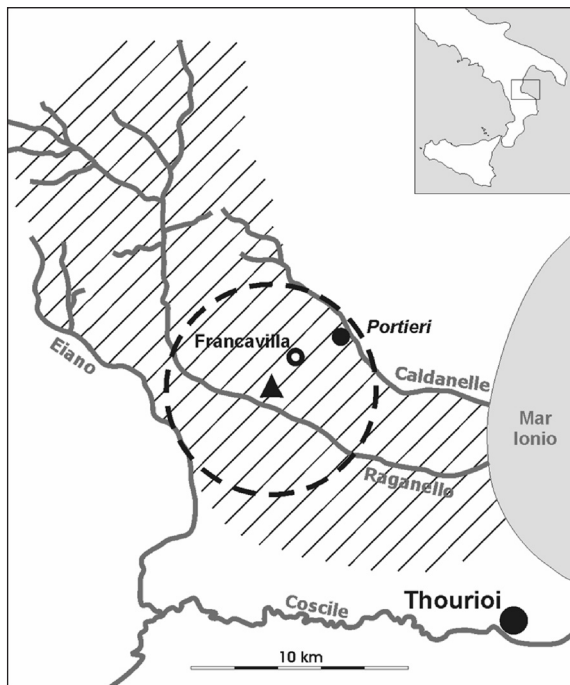

Fig. 1. Research area (GIA).

at a location known as Portieri. The site of Portieri is located to the northeast of present-day Francavilla Marittima, between the rivers Sciarapottolo and Caldanelle in the foothills of the Sibaritide, in the northern part of Calabria (fig. 1). The extent of the site at Portieri, approximately 50 m × 50 m, and the nature of the pottery found, much black gloss ware and many amphorae, make the site stand out from the generally much smaller sites that are characteristic of the Hellenistic rural settlement pattern on the terraces and plateaus in this area. The site was studied in much detail, as it might add to our knowledge of the socio-economic structure of the countryside in the Hellenistic period.

The survey at Portieri is part of a systematic landscape-archaeological research project into long-term settlement development and land use in the coastal plain, foothills and the mountainous interior of the Sibaritide (Attema *et al.*, 2006). Surveys carried out by the RAP in this area in previous years, and even earlier, in the late sixties, by an Italian team of researchers, had already resulted in the mapping of a substantial number of ceramic concentrations in the foothill zone. (Van Leusen & Attema, 2001/02; Quilici *et al.*, 1969). These concentrations date from the protohistoric up to the Hellenistic and Roman periods. It is noteworthy that the Hellenistic ceramic concentrations generally have small dimensions and not much fine pottery.

Until the survey campaign of 2004, it therefore appeared that only remnants of small subsistence farms had been found. Larger rural sites seemed al-



Fig. 2. Location of Portieri site from NW (P.A.J. Attema, GIA).

most absent in the archaeological assemblages from the 4<sup>th</sup> until the 2<sup>nd</sup> century BC. This seemed strange, given the presence of the Greek town of Thourioi in the Sibaritide plain. Thourioi was founded in 444 BC as the successor of the famous Greek colony Sybaris. The latter was destroyed in 510 BC by the rivalling Greek *polis* of Croton. The successful development of Thourioi must have brought changes to the socio-economic structure of its hinterland, which intensive archaeological surveying should be able to pick up on. The site at Portieri, which on account of its pottery can be dated to the early Hellenistic period, indeed is a site of a different and larger type. In this paper the methods of the field survey at Portieri are discussed, as well as the pottery collected in the survey; this is followed by an assessment of its probable function as a wine-producing farm. In the final section a comparison with other Hellenistic sites in southern Italy is made. The paper concludes with a catalogue of diagnostic potshards.

## 2. LOCATION AND SURVEY OF THE SITE

The concentration of Hellenistic pottery was found in an olive grove with young trees on a hill with a fairly flat top known as “Portieri”. The Portieri hilltop lies to the east of the Caldanelle river valley at 245 m above sea level and offers a grand view across the Sibaritide plain (fig. 2). Down in the plain, the contemporary Hellenistic sea port of Thourioi was situated at a distance of 20 km. On its western side, the site of Portieri is protected by the limestone mountain range of the Serra del Gufo, with higher up the twin peaks of the Monte Sellaro. The lower slopes of the Serra del Gufo are nowadays used for the cultivation of cereals and olives. Although Quilici and his team in their previous surveys had found archaeological sites in the surroundings of Portieri, at the time no site was recorded at this particular location.<sup>1</sup>

During the 2004 survey the olive grove had been lightly ploughed, which made for good surface visibility. In accordance with the field methods adopted

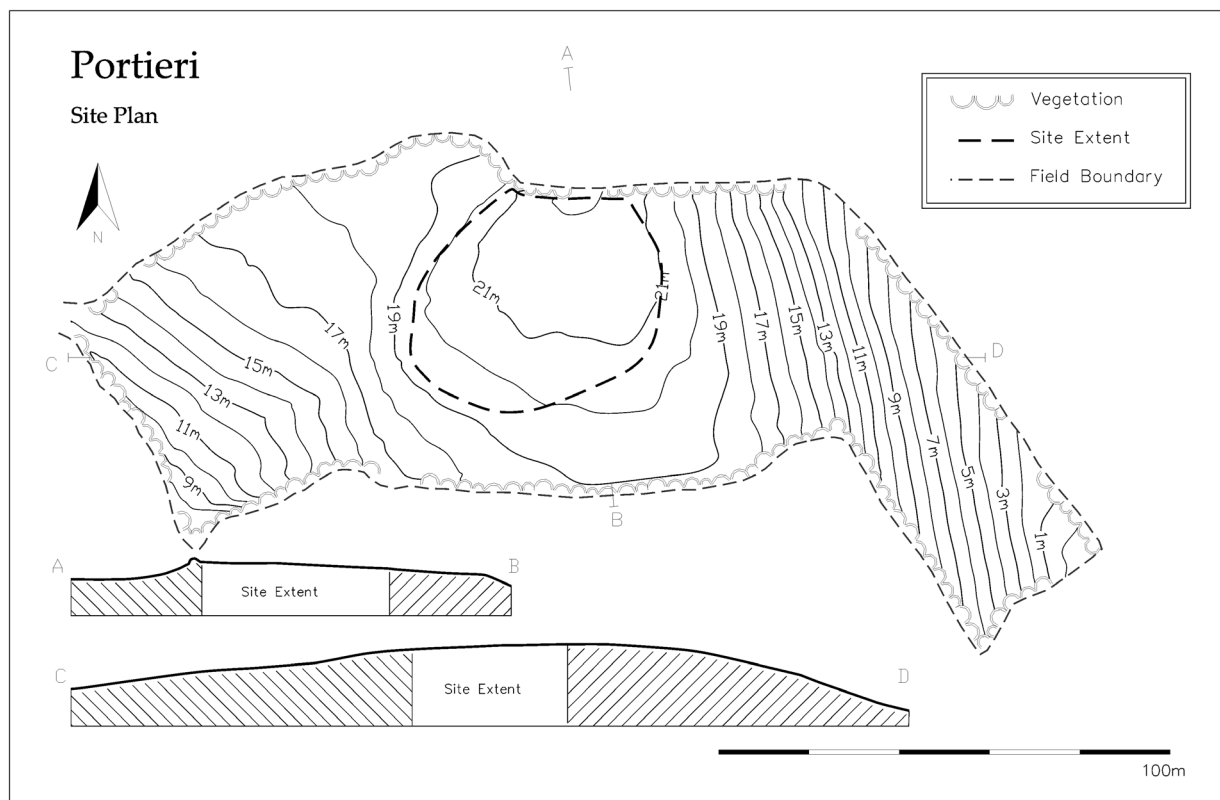

Fig. 3. Site map Portieri (N. Hogan & E. Bolhuis, GIA).

in the RAP surveys, the field was divided into blocks of 50 m × 50 m. These were logged into a handheld field computer linked to a GPS (Van Leusen & Ryan, 2002). The blocks were walked and searched for archaeological materials by the survey team, with a ground coverage of 20%. Two of the blocks were found to contain a very high density of ceramics, over an area of approximately 50 m × 50 m. This area was identified as the site area. Following the standard investigation, the site area was searched more intensively for diagnostic shards (rims, bases, handles).

In October 2005, a revisit took place during which again a small amount of diagnostic material was collected. On this occasion, also a digital relief map of the hilltop was made (fig. 3). The map showed not only that the site area is located on the highest part of the hill, but also that in the Hellenistic period the hill may have been modified for habitation. On the northern side of the site, a flat area is visible in the otherwise sloping hill surface, while the transition to the field immediately to the west is marked by a steep dip, nowadays accentuated by a sub-recent drystone wall (fig. 4). The site area thus seems to have been provided in antiquity with an artificial terrace to create a more prominent position for a Hellenistic building

that presumably was located here. The sub-recent wall that delimits the site plateau to the north is probably made of the foundations and other stone debris of this building removed by farmers from their fields. This would explain why no building materials other than roof tiles have been found in the site area. The next section will discuss the ceramics found in the survey.

### 3. THE POTTERY

In the survey 1474 shards were collected, with a total weight of slightly over 57 kg. These shards were classified into the following categories: tile, coarse ware, depurated ware and black gloss ware (fig. 5a).<sup>2</sup>

From this sample, 521 fragments were of diagnostic value (fig. 5b). These were classified into four functional categories: amphorae, black-gloss tableware, *ceramica comune* and building material (tiles).<sup>3</sup> Of these diagnostic fragments, 218 have been drawn and described (see catalogue). The catalogued shards provided a date for the Portieri site between 350 and 250 BC.

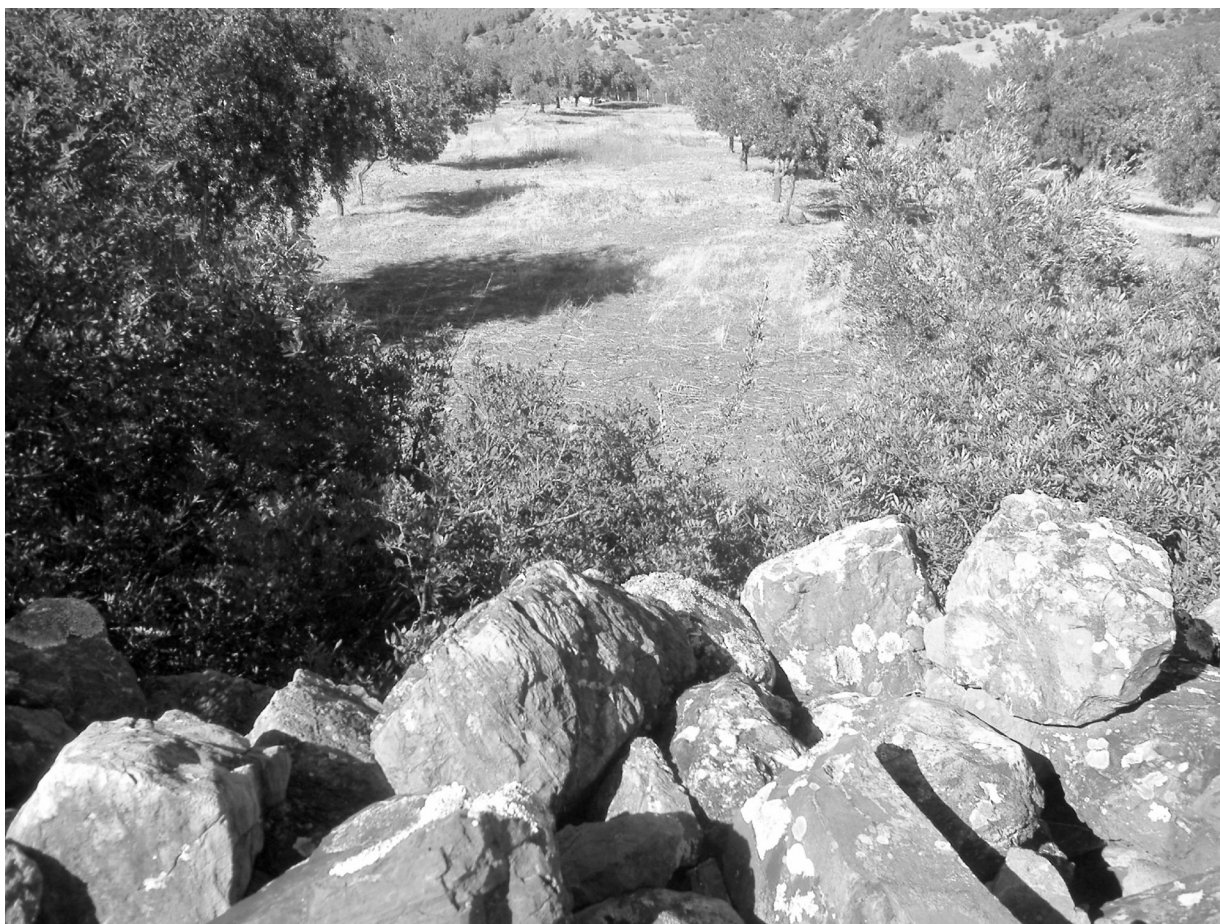

Fig. 4. Sub recent wall and adjacent lower field from SE (N. Oome, GIA).

### 3.1. Amphorae

Among the diagnostic amphora fragments there were many rims and handles and only a few spikes. In the following these will be described under separate headings.

*Rims*: three main rim types were distinguished (although they differ slightly):

- The first type is a slightly outcurved rim that is thickened on the outside. Its lip is triangular in section (see catalogue: Pl. I, Nos AM1-AM9). The lip may be slightly rounded on the in- and outside. The upper surface of the lip is flat or slightly convex. The transition from rim to neck is in some cases marked by a thin horizontal incision. Some have a shallow groove between rim and neck, which in the descriptions is referred to as ‘undercut’;
- The second type is an outcurved rim that is thickened on the outside and differs only slightly from the first rim type. Its lip is triangular in section

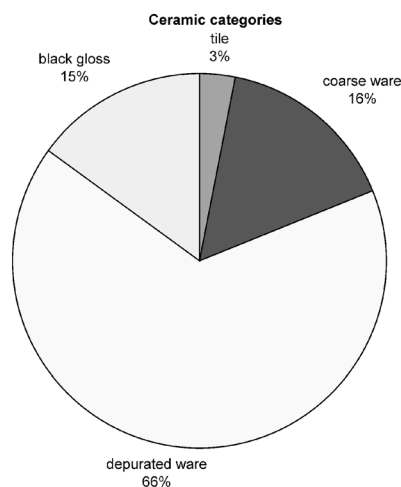

Fig. 5a. Ceramic categories (N. Oome, GIA).

(see catalogue: Pl. I-III, Nos AM10-AM27). The majority of the rims belong to this type. Like the previous type, the lip may be slightly rounded on the in- and outside, while its upper surface is flat or slightly convex. The section of the rim in a few cases is comparatively thin. The transition from rim to neck is often marked by a thin horizontal incision or groove, which in the descriptions is referred to as 'undercut'. The rims of the second type include three fragments that are decorated with a horizontal ridge below the incision or groove between rim and neck (see catalogue: Pl. III, Nos AM28-AM30);

- The third type is outturned with a clear internal angle between rim and neck (see catalogue: Pl. IV, Nos AM31-AM32). This rim type too is thickened on the outside and has a lip that is triangular in section. The lip may be slightly rounded on the in- and outside, while the upper surface is flat or slightly convex. The transition from rim to neck is not marked on the outside. One rim fragment seems to be decorated with an external horizontal groove (see catalogue: Pl. IV, No. AM33).

*Handles:* all are vertical band handles and differ only in the way they are attached to the neck, and in section. Some have a finger imprint where the handle is attached to the shoulder (see catalogue: Pl. IV, No. AM37). Unfortunately no complete handle was found, and consequently the original length of these handles is unknown. Two slightly different types can

be discerned:

- The first type of handle is attached to the neck, bends sharply and then continues straight downwards. Some of them are oval in section, while others are more rounded in section (see catalogue: Pl. IV, Nos AM34-AM35);
- The second type is likewise attached to the neck, but curves slightly upwards before bending downwards. Also some of these handles are oval in section, with others more rounded in section (see catalogue: Pl. IV, No. AM36).

*Spikes:* only nine spike fragments were found. They represent four different types:

- The knob of the first type is convex and its inside is concave. The bottom of the knob is thicker than its walls (see catalogue: Pl. V, No. AM38);
- The knob of the second type, like the first type, is convex with a concave inner surface. Its wall, however, is at first straight and then curves outwards. The bottom is thinner than that of the previous type. This spike type is the longest of the four types (see catalogue: Pl. V, No. AM39);
- The third type of spike has an almost flat knob that is concave on the inside. The walls curve out and are relatively thick compared to the other types (see catalogue: Pl. V, No. AM40);
- The fourth type is cylindrical in shape and has a raised, almost flat base. Its inner surface is convex (see catalogue: Pl. V, No. AM41).

Diagnostic shards in catalogue

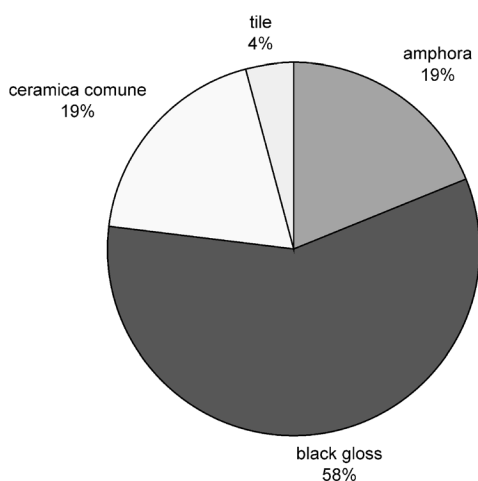

Fig. 5b. Diagnostic shards (N. Oome, GIA).

Diagnostic shards

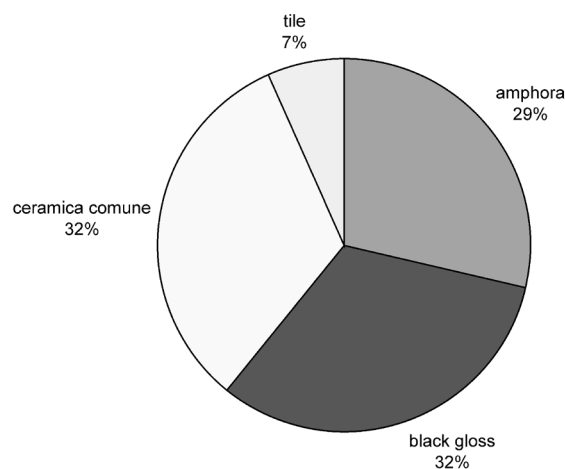
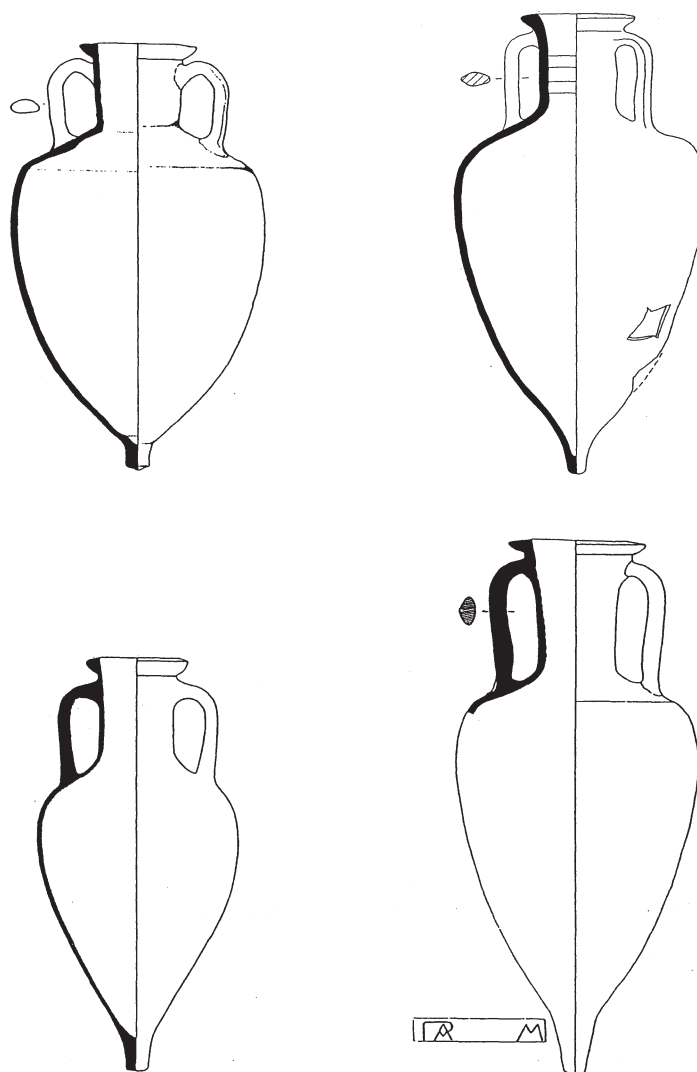

Fig. 5c. Diagnostic shards in catalogue (N. Oome, GIA).

Fig. 6. Amphorae: Vandermersch's types MGS III and IV (Vandermersch, 1994: 70, 74).



#### *Notes on the fabrics*

The fabric of almost all of the amphora fragments consists of a coarse, homogeneous clay. The most commonly occurring fabric has been called "coarse ware A". The clay of this fabric seems deperated, but it contains many small inclusions that make the surface rough. The colour of the paste of coarse ware A varies little and generally it is red (2.5YR 6/6).

Amongst the amphora shards is a small group of coarse ware fragments that can be divided into coarse ware with larger inclusions ("coarse ware B") and coarse ware that is sandier ("coarse ware C"). The colour of the pastes of coarse wares B and C is also mainly red (2.5YR 6/6). Furthermore, there are some amphora fragments made of deperated clay. The colour of their paste varies from red (2.5YR 6/6) to reddish yellow (5YR 7/6 and 7.5YR 7/6).

#### *Typological classification*

The amphora fragments from Portieri can be classified according to the typo-chronology drawn up by Vandermersch for the South Italian and Sicilian amphorae (Vandermersch, 1994) (fig. 6). These are the so-called MGS types, which is short for Magna Grecia and Sicily. While parallels for the spikes were difficult to find, the rims and handles of the Portieri amphorae appear to bear a close resemblance to Vandermersch's type MGS III. Parallels for this amphora type have been found at the site of Thourioi (Vandermersch, 1994: 71–72). Only a few Portieri amphora fragments are comparable to his type MGS IV, of which just one fragment has turned up in Thourioi (Vandermersch, 1994: 73).

Typologically, both types have straight or slightly outcurved rims, which are triangular in section and

Fig. 7. Black gloss (N. Oome, GIA).

| <i>Open forms</i> | <i>Closed forms</i> |
|-------------------|---------------------|
| Plate             | Jug                 |
| Bowl              | <i>Lekythos</i>     |
| Cup               | Lamp                |
| <i>Skyphos</i>    |                     |
| Crater            |                     |

have a flattened lip (Vandermersch, 1994: 70, 73–74). Another characteristic feature is the accentuated transition from rim to neck. Further, the vertical band handles too are similar to Vandermersch's types MGS III and IV, sometimes even down to the finger imprint where the rim is attached to the shoulder.

Thourioi is named by Vandermersch as one of the production sites of MGS III and IV amphorae.<sup>4</sup> The function of these amphorae is thought to be the storage and transportation of wine (Vandermersch, 1994: 72). Vandermersch dates the MGS III amphorae between the late 5<sup>th</sup> century and 330/310 BC, while the MGS IV amphorae are dated in the entire 4<sup>th</sup> and early 3<sup>rd</sup> century BC (Vandermersch, 1994: 72, 76).

### 3.2. Black gloss

Apart from the large quantity of amphorae, also a sizeable amount of black gloss pottery was found at the Portieri site. Especially fragments of drinking cups (*skyphoi*) and jugs are present in considerable numbers, but also plates, bowls and small cups can be distinguished. All shapes belong to tableware.

However, not all tableware was painted with black gloss. Several non-painted jugs and some large dishes, which were used in the kitchen for the preparation of food, may also have been put on the table (Barra Bagnasco, 1989b: 10–14; Nava & Osanna, 2001: 63–71). Their forms were more or less the same as the painted ones (Barra Bagnasco, 1989b: 12; Nava & Osanna, 2001: 67–68).

Many fragments of the black gloss ceramics in the catalogue of the Portieri site have parallels at Locri (Barra Bagnasco, 1989a), at Roccagloriosa (Gualtieri & Fracchia, 1990) and in the Brettia area (Mollo, 2003). Comparable types also appear in Morel's black gloss typology (Morel, 1981). Finally, many similar fragments have been found at Thourioi, where products from the countryside must have been traded and where ceramics may have been produced and sold (*Atti Lincei*, 1970, 1972, 1974 and 1988/89). These parallels suggest a dating for the Portieri site of approximately 350–250 BC.

The black gloss pottery from the Portieri site can be divided into open and closed forms (fig. 7). The various forms of each category will be described in the following.

#### *Open forms:*

– Plate. Plates can be divided into three types (fig. 8). The first type has an incurved rim that is thickened on the outside and has a diameter of at least 30 cm (see catalogue: Pl. V, Nos BG1–BG4). The second type has a flaring or incurved wall with a straight rim and a flattened lip that may be thickened on the outside. The diameter varies between c. 7 to 10 cm (see catalogue: Pl. V, Nos BG5–BG9). Typologically these plates have parallels in Morel's classification (1981: Nos 2237 and 2283–2286). Comparable plates have also been found at Roccagloriosa (Gualtieri & Fracchia, 1990: Nos 134 and 140), at Cetraro (Mollo, 2003: Nos C118 and C119) and at Thourioi (see catalogue). Finally, a third type of plate has been distinguished with an outturned rim and a convex lip that is thickened on the outside (see catalogue: Pl. V, Nos BG10–BG11). The bases of the plates probably were flaring ring bases with a rounded edge (see catalogue: Pl. VI, Nos BG12–BG16).

– Bowl. Bowls occur with various rim types (fig. 9). The first rim type is outcurved, with a rounded lip thickened on the outside. Its diameter varies from 12 to 23 cm (see catalogue: Pl. VI, Nos BG17–BG19). Parallels for this type may be found at Roccagloriosa (Gualtieri & Fracchia 1990: Nos 130 a and b). The second rim type is upright or incurved and has a very pronounced collar. Its diameter is between 20 and 30 cm (see catalogue: Pl. VI, Nos BG20–BG22). Probable parallels of this type are found in Morel's classification (1981: Nos 1552 and 2538). A third rim type is slightly incurved and its collar, although closely resembling it, is less pronounced than that of the previous rim type (see catalogue: Pl. VII, Nos BG23–BG25). Its diameter varies from 12 to 20 cm. Another rim type has a very slightly incurved rim with a convex lip. These bowls have a striking red clay colour (see catalogue: Pl. VII, No. BG26). A parallel has been found in Morel's classification (1981: No. 4121). Bases belonging to the bowls probably were flaring ring bases with a rounded edge, just like the bases of the plates, but with larger diameters (see catalogue: Pl. VII, Nos BG27–BG28). Two bases were identified as belonging to the so-called *kylix* type of bowl (see catalogue: Pl. VII, Nos BG30–BG31).

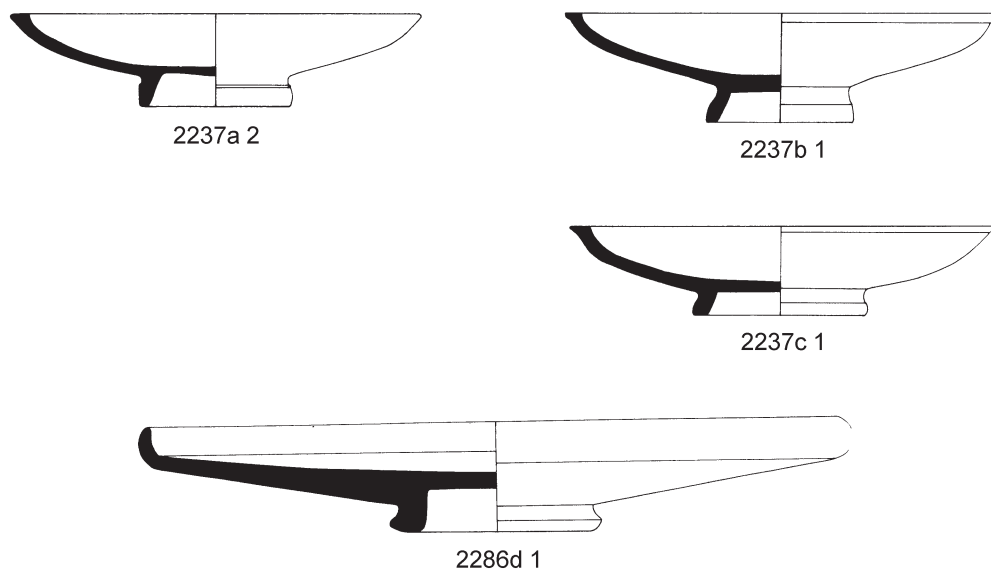

Fig. 8. Parallels for Portieri plates (Morel, 1981: Nos 2237 and 2286).

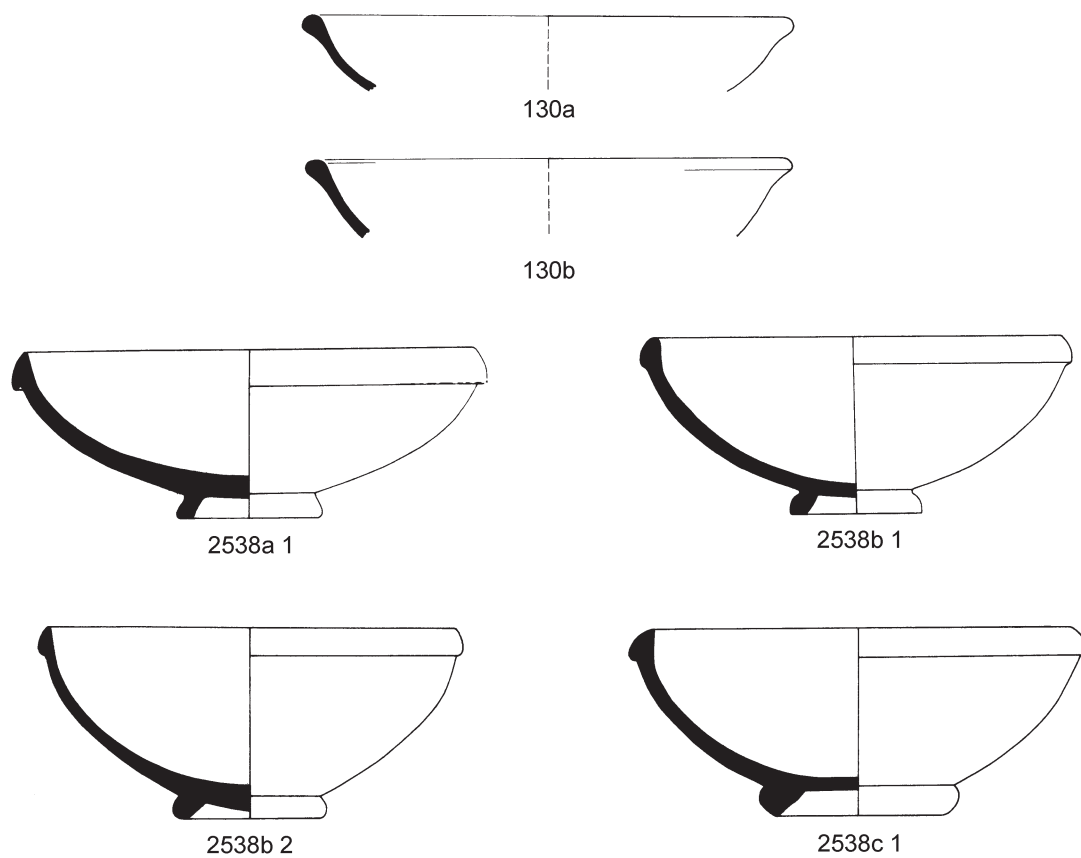

Fig. 9. Parallels for Portieri bowls (Gualtieri & Fracchia, 1990: 130a-b and Morel, 1981: No. 2538).



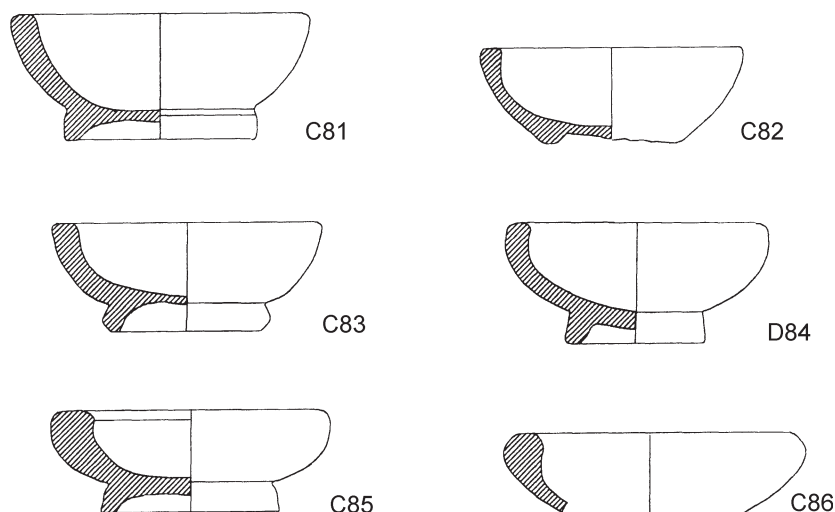

Fig. 10. Parallels for Portieri cups (Mollo, 2003: Nos C81-86).

These are flaring ring bases with a horizontal ridge on the exterior of the foot. By the look of their clay they may be of Attic production or indeed imitations of Attic ceramics produced in Magna Graecia. Parallels for this type of bowl have been found in Morel's classification (1981: Nos 4221-4222). Another base found at Portieri probably is an imitation of Attic pottery (see catalogue: Pl. VII, No. BG29).

- Cup. As to the cups (fig. 10), the types occurring most frequently are those with a flaring wall and a straight rim with a (slightly) convex or flattened lip (catalogue: Pl. VII, Nos BG32-BG37). The bases of these cups were flaring ring bases (see catalogue: Pl. VIII, Nos BG45-BG46) and a flatter type of ring base (see catalogue: Pl. VIII, Nos BG42-BG44). Parallels for these cups are known from Cetraro (Mollo, 2003: Nos C81-C86) and Thourioi (see catalogue). Besides these cups, Portieri also yielded some exceptional rim types belonging to cups (catalogue: Pl. VIII, Nos BG38-BG41).<sup>5</sup> Further, a base fragment appeared with a remarkable impressed design on its interior surface that consists of four palm leaves around a circle (catalogue: Pl. VIII, No. BG47) (fig. 11). This decoration seems to be a simplification of a motif marking the end of a long decorative tradition of this type (Barra Bagnasco, 1989a: 188–190). A clear parallel was found at Locri (Barra Bagnasco, 1989a: No. 197), while similar fragments also turned up in the excavations of Thourioi (Barra Bagnasco, 1989a:

124 and 190; *Atti Lincei*, 1974: 523, fig. 484 (6061) and 526, fig. 486 (10383)).

- *Skyphos*. Within the group of *skyphoi* (fig. 12), many small variants were distinguished. Generally the rims are upright or slightly outcurved (catalogue: Pl. VIII, Nos BG48-BG55). There is a striking fragment decorated with two horizontal incised lines on the exterior just below the rim. This type of decoration on a *skyphos* seems characteristic of *skyphoi* from Roccagloriosa (Gualtieri & Fracchia, 1990: No. 78). Parallels for the *skyphoi* are not only found at Roccagloriosa (Gualtieri & Fracchia, 1990: Nos 71, 73 and 74), but also in the area of Acquappesa and Cetraro (Mollo, 2003: Nos C14, C32, C33 and C42) and at Thourioi (see catalogue). Also a few handle fragments with rim have been

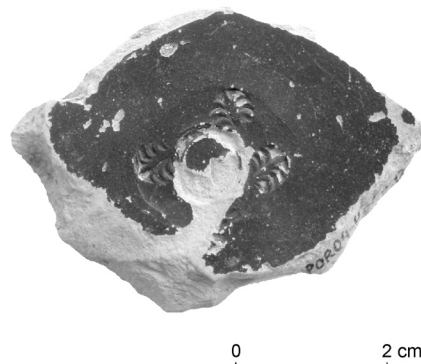

Fig. 11. Decoration of palm leaves (N. Oome, GIA).

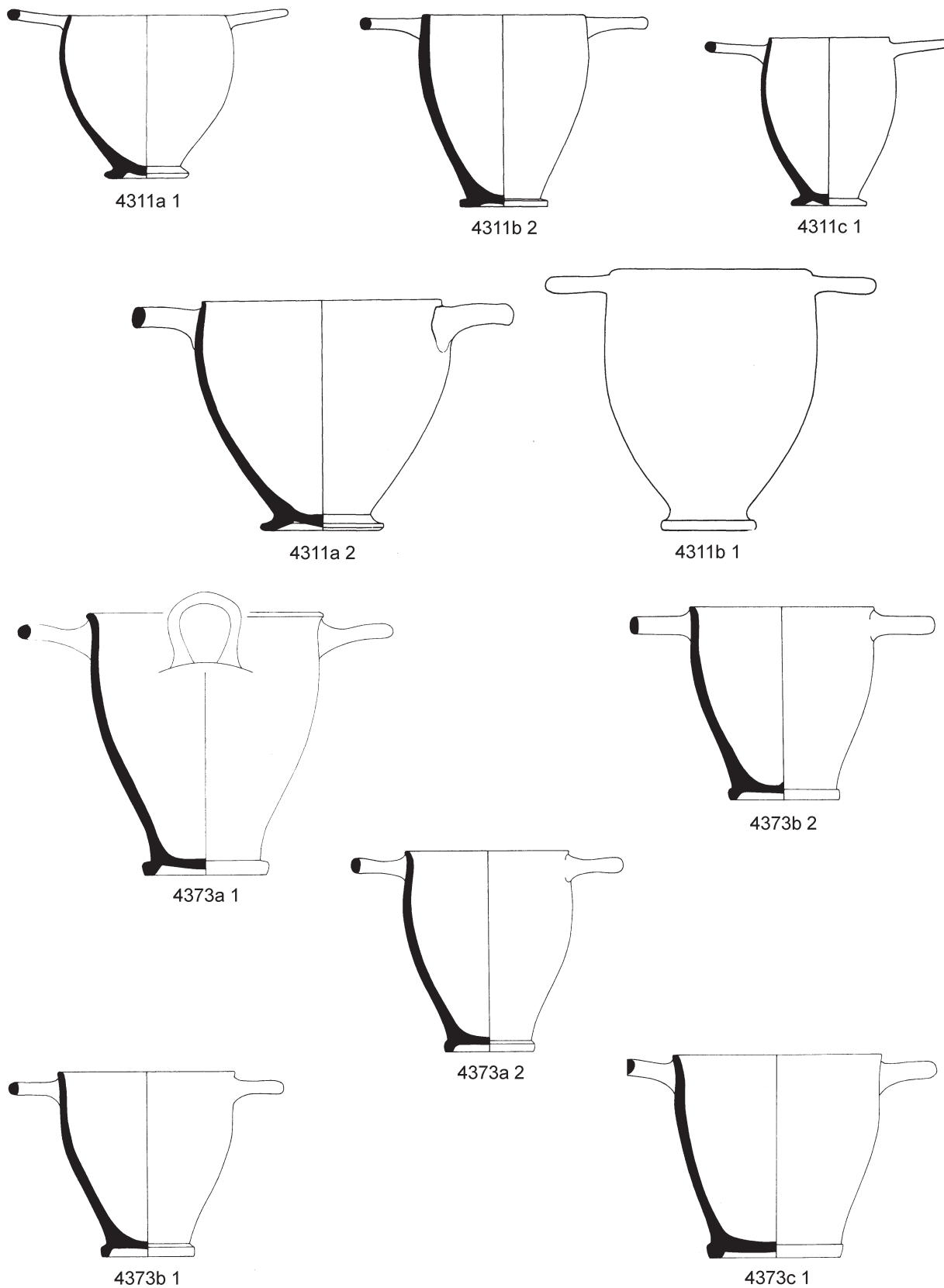

Fig. 12. Parallels for Portieri skyphoi (Morel, 1981: Nos 4311 and 4373).

found at Portieri, obviously belonging to *skyphoi* (see catalogue: Pl. IX, Nos BG56-BG57). The bases of the *skyphoi* can be divided into three groups, which all have parallels at Thourioi (see catalogue). The first group consists of flaring ring bases with an outturned foot with a rounded edge (see catalogue: Pl. IX, Nos BG58-BG61). These bases have parallels in Morel's classification (1981: No. 4311) and probably are imitations of Attic pottery produced in the south of Italy. The second group contains flaring ring bases with a more upright foot with a thinner rounded edge (see catalogue: Pl. IX, Nos BG63-BG65). According to Morel's classification (1981: No. 4373) these bases can be attributed to Apulian producers. The bases of the third group are flaring ring bases with an upright foot with a bevelled edge (see catalogue: Pl. IX, BG66-BG71). Some of these have a decoration of black circles on the exterior of the base. Between these circles the paste colour is visible. For these bases too, parallels are found in Morel's classification (1981: Nos 4352, 4373) and at Roccagloriosa (Gualtieri & Fracchia, 1990: No. 81b). The *skyphoi* with decoration may be either of original Attic provenance or local imitations.

- Crater. The last group within the category of open forms consists of crater fragments (see catalogue: Pl. X, Nos BG72-BG75). An outturned crater rim, a lug and two probable crater bases have been identified. Parallels for these fragments were found in Morel's classification (1981: No. 4618), at Locri (Barra Bagnasco, 1989a: Nos 272-273) and at Thourioi (see catalogue).

*Closed forms:*

- Jug. The first group of closed forms are the jugs (fig. 13). Although probably not all of these were painted with black gloss, they typologically belong to the same type of jug and both will have served for pouring out beverages. For this reason, painted and plain jugs have been put together in the same category. The rims of the jugs are rather varying between straight, slightly incurved and outcurved (see catalogue: Pl. X-XII, Nos BG76-BG99). All have flattened lips. Few rims seem to have some kind of interior ridge to support a lid (see catalogue: Pl. XI, Nos BG90-BG92). Parallels for the jugs are quite difficult to find. Only at Thourioi (see catalogue) comparable fragments have been found and possibly one type in Morel's classification (1981:

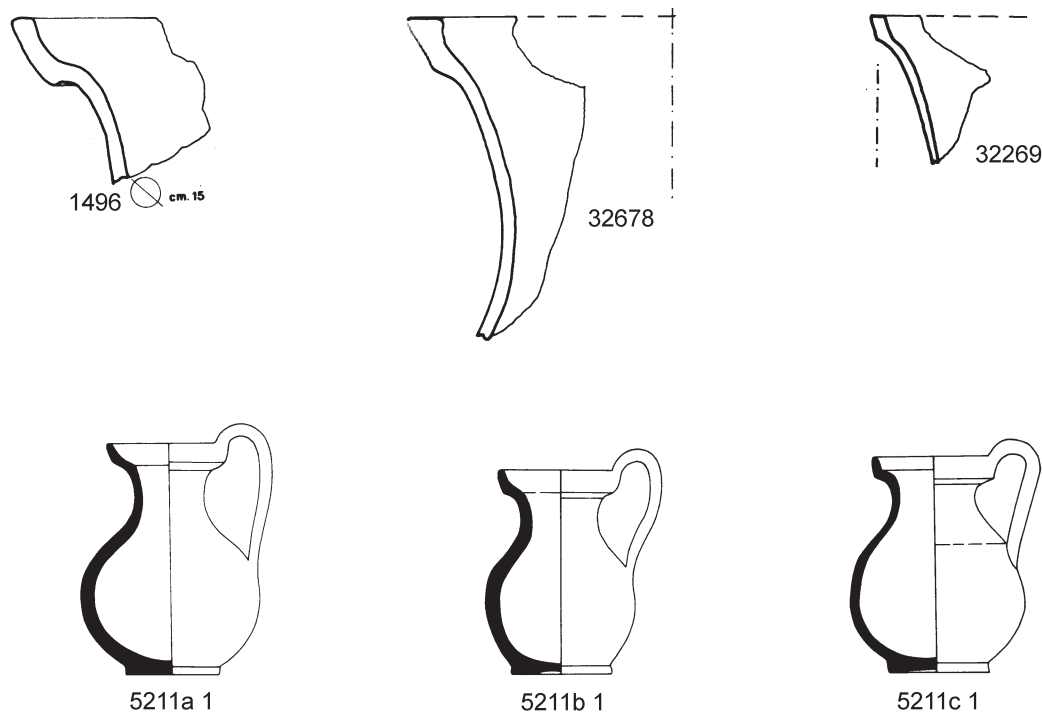

Fig. 13. Parallels for Portieri jugs (*Atti Lincei*, 1988/89: 280, Inc. 1496; 511, PS 32269; 515, PS 32678 and Morel 1981: No. 5211).

No. 5211) may be similar. Since so few parallels have been found for these relatively numerous jug rims, local production in the north of Calabria may be assumed.<sup>6</sup> The bases of the jugs are flaring ring bases with a slightly outcurved, rounded edge (see catalogue: Pl. XII, Nos BG108-BG109). Other jug bases found at Portieri probably belonged to so-called *olpai* (see catalogue: Pl. XIII, Nos BG110-BG115). For these *olpai* bases too, parallels have been found only at Thourioi (see catalogue). It is not clear which rims belong with the *olpai* bases.

- *Lekythos*. Another group of closed forms are the *lekythoi*, only a few fragments of which have been identified. The rim fragments are all outcurved, with a convex or flattened lip (see catalogue: Pl. XIII, Nos BG117-BG121). The bases all have a small, flaring base ring with an outcurved, rounded edge (see catalogue: Pl. XIII, Nos BG124-BG126). A very clear *lekythos* fragment is the wall fragment decorated with a lozenge pattern on the exterior and a circle of solid colour around the handle attachment (see catalogue: Pl. XIII, No. BG122) (fig. 14). Various parallels for this fragment have been found at Thourioi (see catalogue).
- Lamp. Finally, two lamp fragments were recovered. One is just a small part of the spout. The other fragment is a spout with part of the belly, on which an oval stamp can be seen, just below the attachment of what may be a handle (see catalogue: Pl. XIII, No. BG127). No parallel has yet been found for this lamp fragment.

#### Notes on the fabrics

The fabric of most of the black gloss ceramics ap-



Fig. 14. Decorated *lekkythos* fragment (N. Oome, GIA).

Fig. 15. Ceramica Comune (N. Oome).

| <i>Depurated clay</i> | <i>Coarse ware clay</i> |
|-----------------------|-------------------------|
| Basin                 | Miscellaneous           |
| Mortar                | Cooking pot             |
| “Pelvis”              | Storage vessel          |
| Cooking pot           | Storage vessel          |

pears to be homogeneous and generally consists of highly depurated clay with a light reddish brown colour (5YR 6/4). However, a few recovered fragments have quite a soft fabric and a very pale brown colour (10YR from 8/4 to 7/4). Some fragments may have been of Attic production, given their soft and highly depurated fabric. They have a reddish yellow (5YR 6/6) and pinkish grey colour (7.5YR 6/2) with very small, glittering inclusions. A few fragments have a reddish colour (2.5YR 6/6) and some of these have a remarkably hard fabric. Some *skyphoi* fragments have a red fabric with patches of grey (2.5YR 6/6 and 5YR 6/1). Finally, there are a few fragments with a very strong orange colour (2.5YR 6/8).

### 3.3. *Ceramica Comune*

This category contains depurated, non-painted pottery as well as coarse ware (fig. 15). These were all used in the kitchen for the preparation and storage of food, although the coarse ware forms were better able to resist the heat of fire. As said before, non-painted depurated *ceramica comune* might also be put on the table. Indeed some of the basins and mortars assigned to this category seem to have traces of black gloss. However, they have been considered here as *ceramica comune* because of corresponding fragments without any traces of gloss and because of parallels which assign them to this (functional) category.

Parallels for the *ceramica comune* have been found at Locri (Barra Bagnasco, 1989a), at Roccagloriosa (Gualtieri & Fracchia, 1990), in the Brettia area (Mollo, 2003) and at Thourioi (*Atti Lincei*, 1970, 1972, 1974 and 1988/89). Again the parallels suggest a dating for the Portieri site in the period from approximately the mid 4<sup>th</sup> to mid 3<sup>rd</sup> century BC. Below, the fragments made of depurated clay will be considered first, and then the coarse ware.

#### *Ceramica Comune of depurated clay:*

- Basin. The basins are all of roughly the same type (fig. 16). They have straight rims with a convex lip that is thickened on the in- and outside; in some

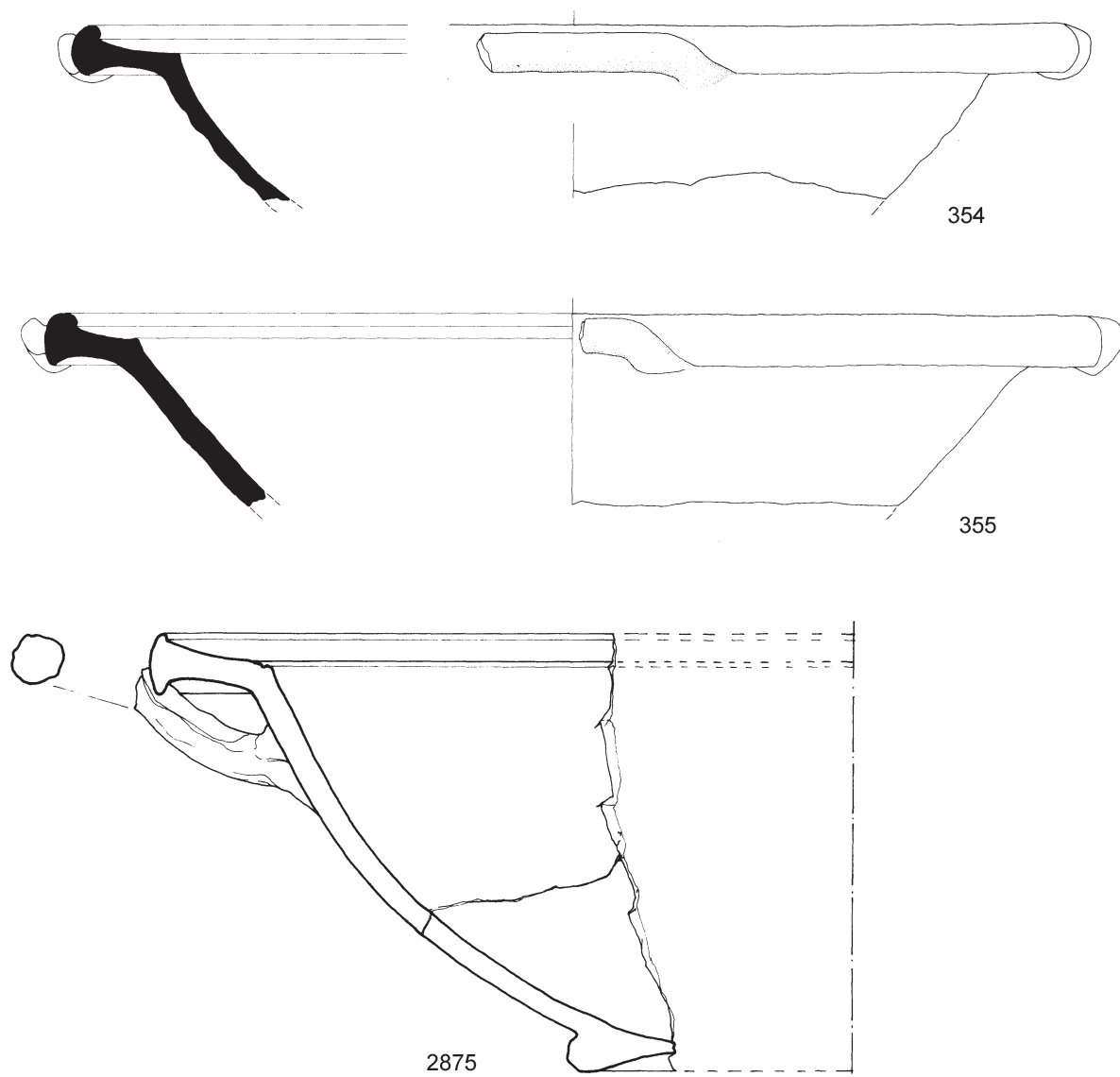

Fig. 16. Parallels for Portieri basins (Barra Bagnasco, 1989a, No. 354-355 and *Atti Lincei*, 1988-89: 227, St. 2875).

cases, the internal angle of the outturned wall is preserved (see catalogue: Pl. XIV, Nos CC1-CC6). Two of these fragments also preserve the attachment and remnant of a horizontal ring handle. These were situated below the outturned part of the rim and almost touched the lip (see catalogue: Pl. XIV, Nos CC5-CC6). Parallels for this type of basin have been found at Locri (Barra Bagnasco, 1989a: Nos 354-355) and at Thourioi (see catalogue).

- Mortar. The Portieri material includes a particular type of mortar of depurated clay (fig. 17). It has a flaring wall with an outturned rim and a convex lip that is thickened on the outside and curves down-

wards (see catalogue: Pl. XIV-XV, Nos CC7-CC9). Comparable forms have been found at Locri (Barra Bagnasco 1989a: No. 349) and Thourioi (see catalogue).

- "Pelvis" basin. This type of basin has a slightly incurved rim and a convex lip that is thickened on the outside (see catalogue: Pl. XVI, Nos CC10-CC11) (fig. 18). The basin is called "pelvis" in accordance with parallels found at Thourioi (see catalogue). The horizontal groove on the exterior of the rim should be noted. These basins might have a spout for pouring out a liquid (see parallels).

Fig. 17. Parallel for Portieri mortars (Barra Bagnasco, 1989a: No. 349).

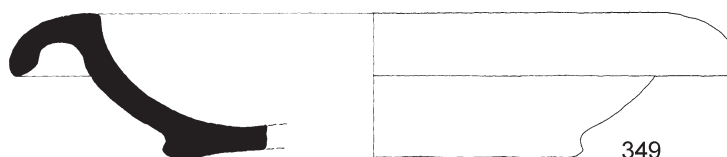
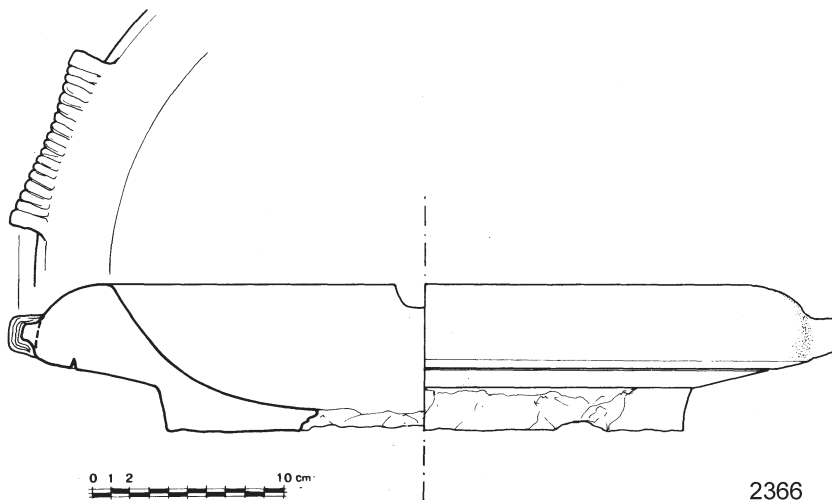

Fig. 18. Parallel for Portieri "pelvis" basins (*Atti Lincei*, 1988–89: 585, CB 2366).



- Cooking pot. Two fragments may belong to cooking pots, despite being made of depurated clay (see catalogue: Pl. XV, Nos CC12-CC13). The first fragment looks similar to the so-called “casseroles” and may be assumed to belong to a cooking pot. The second fragment, although it has traces of black gloss, has a probable parallel at Thourioi.
- Storage vessel. One fragment seems to be the base of a storage vessel (see catalogue: Pl. XV, No. CC15), which possibly has a parallel at Thourioi (see catalogue). Also a rim of what probably was a storage vessel was identified. It is an upright rim with a flattened lip thickened on the outside (see catalogue: Pl. XVI, No. CC14). For this fragment no parallel has as yet been found.

#### *Ceramica Comune of coarse clay*

- Miscellaneous. Two small fragments possibly of bowls have been found (see catalogue: Pl. XVII, Nos CC16-CC17), but no parallels are apparent. Also a small knob of an incomplete lid has been distinguished (see catalogue: Pl. XVII, No. CC18). Furthermore, three rim types could be distinguished: with outcurved, upright or barely outturned rims (see catalogue: Pl. XVII, CC19-CC21). For these, parallels have been found at Thourioi (see catalogue) and Cetraro (Mollo, 2003: No. D93). There

are many different handle fragments probably belonging to jugs (see catalogue: Pl. XVII-XVIII, Nos CC22-CC31), but without any parallels.

- Coarse-ware cooking pots. These can be divided into three different types. The first type is that of the so-called *chytrai*, which have an upright rim and a convex lip that is thickened on the outside (catalogue: Pl. XVIII, Nos CC32-CC33). So far, only one comparable form has been found, at Roccagloriosa (Gualtieri & Fracchia, 1990: No. 249). The second type is the *pentola* type of cooking pot. These have a slightly incurved wall, straight rim and convex lip that is thickened on the outside (catalogue: Pl. XVIII, Nos CC34-CC35). A similar type was found at Locri (Barra Bagnasco, 1989a: No. 298). The so-called “casseroles” form the third type of cooking pot (fig. 19). These have an upright or incurved rim, a flattened lip that is thickened on the inside and a ridge on the inside of the rim, just below the lip (catalogue: Pl. XVIII, Nos CC37-CC38). This ridge serves to support a lid. Parallels for this type have been found at Locri (Barra Bagnasco, 1989a: No. 316) and at Thourioi (see catalogue). Only one probable base of a cooking pot was distinguished, which is concave inside and only slightly concave outside (catalogue: Pl. XIX, No. CC39). No parallels have been found,

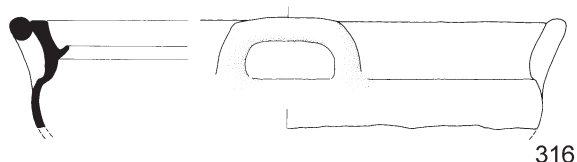

Fig. 19. Parallel for Portieri "casserole" (Barra Bagnasco, 1989a: No. 316).

but it may be assumed that this base belonged to one of the cooking pots.

- Storage vessels. Two fragments of storage vessels of coarse ware clay have been found. The first fragment is an upright rim and has a flattened lip that is thickened on the outside (catalogue: Pl. XIX, No. CC40). The other fragment is a vertical ring handle with the attachment to the neck (catalogue: Pl. XIX, No. CC41). Again, no parallels have yet been found.

#### Notes on the fabrics

The fabric of the *ceramica comune* is fairly homogeneous. The depurated, unpainted surface is quite soft and generally has a red (2.5YR 6/6) or reddish yellow (5YR 6/6) colour. The coarse-ware clay too is quite soft and has a red colour (mainly varying from 2.5YR 5/8 to 6/8).

#### 3.4. Tiles

The last category of the Portieri ceramics to be discussed are the roof tiles. The rim fragments of the tiles are very similar and display only little variation (see catalogue: Pl. XX, Nos BM1-BM7). Possibly they also include an *imbrex* fragment (see catalogue: Pl. XX, No. BM9). No clear parallels for these tiles can be indicated.

The fabric of this building material again looks quite homogeneous, although the clay of the first three fragments contains more sandy inclusions than the others. Its colour generally varies from red (2.5YR 6/6 or 6/8) to reddish yellow (7.5YR 7/6).

### 4. FUNCTION AND CHRONOLOGY OF THE PORTIERI SITE

#### 4.1. Portieri site

Since the site of Portieri has not been excavated and we consequently lack information on the kind of building to which the pottery and roof tiles belong,

we have to rely on the ceramic finds as our sole source for obtaining an understanding of the site's function. We already noted that wine amphorae constitute a substantial part of the ceramic assemblage at Portieri. The quantity of amphorae well exceeds the needs of a single family and we therefore assume that we are dealing with a farmstead where wine was produced, stored and transported. Parallels for the types of amphorae found at the site suggest a close connection with Thourioi, where the amphorae also may have been produced. They would then have been filled at the farm, to be transported back to Thourioi or another destination.

The presence of storage and cooking vessels as well as black gloss and depurated tableware within the ceramic assemblage of Portieri indicates that the farmstead was inhabited throughout the year by a family who may also have owned the farm, although external ownership by entrepreneurs from Thourioi is a possibility as well. The black gloss ceramics found at Portieri in part belong to the category of *symposium* tableware.<sup>7</sup> This indicates that the inhabitants of the Portieri site enjoyed a certain social standing.

The ceramic scatter of approximately 50 m × 50 m is among the larger scatters that up till now have been mapped at individual rural sites in the surveys of the RAP. The presence of roof tiles in combination with the stone rubble scattered about the field and piled up in the terrace wall indicates that we are dealing with a substantial building. However, the fact that only few tiles have been found implies that only part of the structure is likely to have been covered with roof tiles, possibly only the living quarters. An additional indicator that we are dealing with a site of some importance is its location in a commanding position in the foothills of the Sibaritide, with a fine view over the Sibaritide plain, the rural territory of Thourioi and the sea.<sup>8</sup> The various categories of pottery that are discussed indicate that the farm was active over a period of approximately 100 years between 350 and 250 BC. In the next paragraph we shall make some suggestions as to the physical appearance of the site. The best examples of Hellenistic farmhouses to date are found in the coastal plain of the Metapontino, north from the Sibaritide, but excavated examples are known also from the Sibaritide itself. We shall start with the latter.

#### 4.2. Other farmhouses in the Sibaritide

Opposite the Portieri site, across the Caldanelle river, a farmstead has been documented at Montegiordano. This site lies at a distance of 35 km from Thourioi and 25 km from Heraclea and would have been in

Fig. 20. Plan of Fattoria at Montegiordano (Russo Tagliente, 1992: 184, fig. 110).

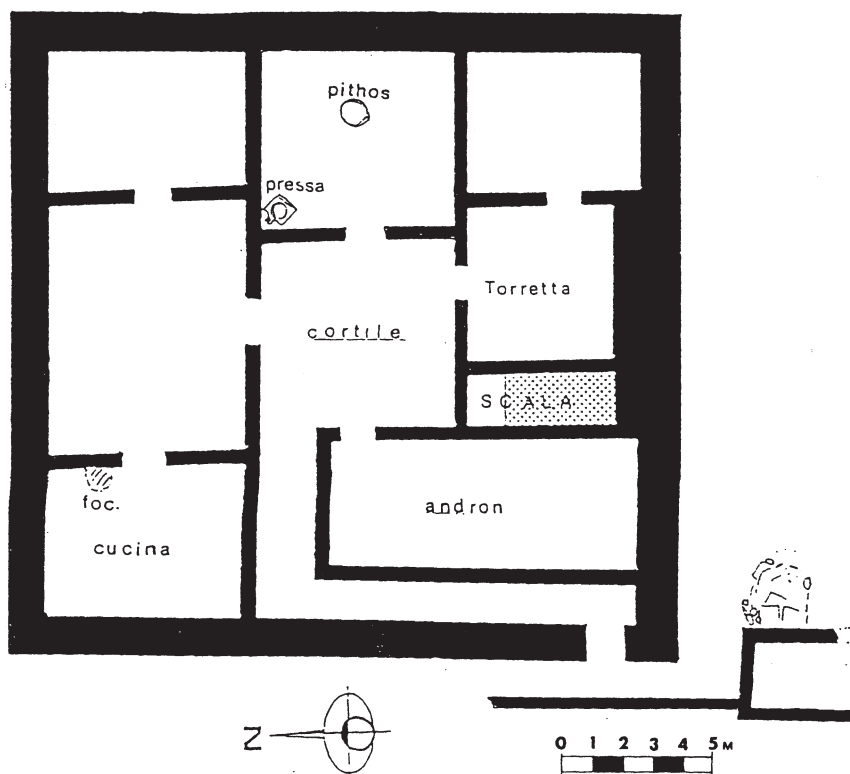

Lucanian territory (Russo Tagliente, 1992: 183–185; Russo, 1996: 78–83).

The plan of this building measures 22 m × 22 m (fig. 20). It has very thick outer walls and a narrow entrance consisting of two square corridors leading into a central courtyard. At the south side of the building there was a tower, which commanded a fine view over the sea and over the territory of Thourioi.<sup>9</sup> These architectural features and the strategic position in the countryside have prompted scholars to attribute a military function to this farmstead (Russo Tagliente, 1992: 185). The finds from the building, however, indicate a regular form of habitation. The room to the west of the tower yielded fragments of plaster and tableware – such as craters and drinking vessels – which suggest a function as a reception room, the Greek *andron*. This would imply a certain social status of the occupants (Russo Tagliente, 1992: 184–185). The room in the northwest of the building probably was a room used by women, judging by the many loomweights and *lekythoi* (small vases for perfumed body oil) that were found here. In this same room close to a hearth some statuettes of a female figure seated on a throne were found, which points to a cult involving a divine protectress of the hearth and to women's activities. The adjacent room to the east could have been a communal

living room and the room next to this one could have been a bedroom, as well as the room in the southeast of the plan. In the room to the east of the courtyard a storage jar (*pithos*) and an olive press were found as evidence for the agricultural function of this building (Russo Tagliente, 1992: 183–184). The presence of an oven and the remains of small outhouses next to the building support the interpretation of the structure as having accommodated a self-sufficient family household (Russo Tagliente, 1992: 185). Whether the economy of the site was purely subsistence or aimed at a modest amount of trade by barter is, according to Russo Tagliente, open to debate.

Another farmstead found in the Sibaritide is the *Fattoria di Stombi*. This farmstead was built on top of older remains in the former Archaic district of Sibari (Greco, 2001: 189; Greco, 2003: 369, 372, fig. 3; *Atti Lincei*, 1988/89: 171–179). The structure probably had five rooms and a cistern, and maximum external measurements of 14.5 m along the south side and 9.5 m along the west side (fig. 21) (*Atti Lincei*, 1988/89: 171). The north and east sides are incomplete, and also parts of the inner walls seem to be lacking. Inside the structure, the excavations uncovered only a few rocks (*Atti Lincei*, 1988/89: 171–172). Some of the walls have foundations of loosely piled river boulders (*Atti Lincei*, 1988/89: 175). Furthermore, many flat tiles



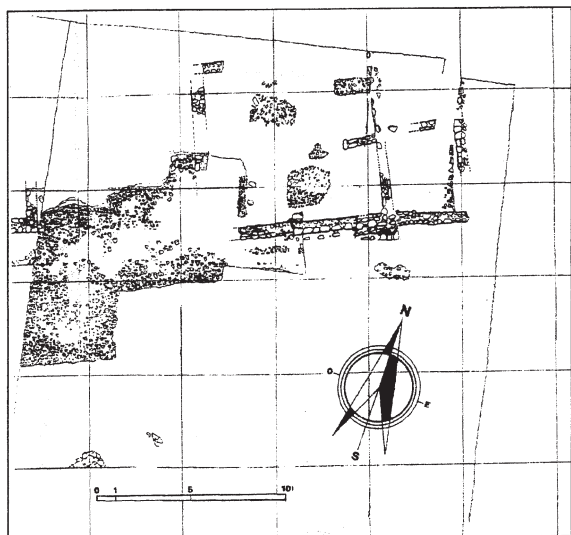

Fig. 21. Plan of 'edificio c' at Stombi (Greco, 2003: 372, fig. 3).

and pentagonal *imbrices* came to light, which used to cover the roof of the building (*Atti Lincei*, 1988/89: 171–172).

In the heyday of Thourioi, the location of the *Fattoria di Stombi* fell outside the urban built-up area of Thourioi and hence was probably one of the farmsteads in the *chora* (Greco, 2003: 372). The recovered ceramics date the farmstead to the 4<sup>th</sup> and 3<sup>rd</sup> century BC (Greco, 2001: 189).<sup>10</sup>

#### 4.3. Farmhouses in the Metapontino

In the Metapontino, various farmsteads have been excavated. Of these, three may serve as instructive, more or less contemporary examples of the type of farmstead we are dealing with in the case of Portieri.

The first farmstead is the so-called *Fattoria Fabrizio* (fig. 22). It is located on a slope midway between the

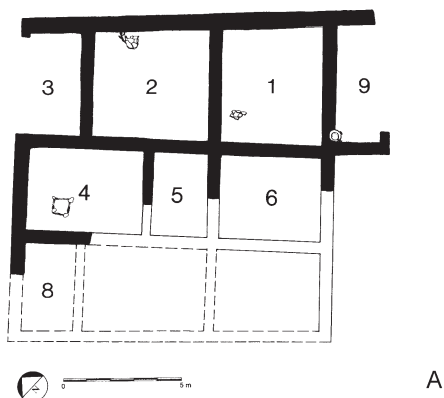

Fig. 22. Plan of *Fattoria Fabrizio* (Carter, 2006: 139, fig. 4.3 and 4.4).

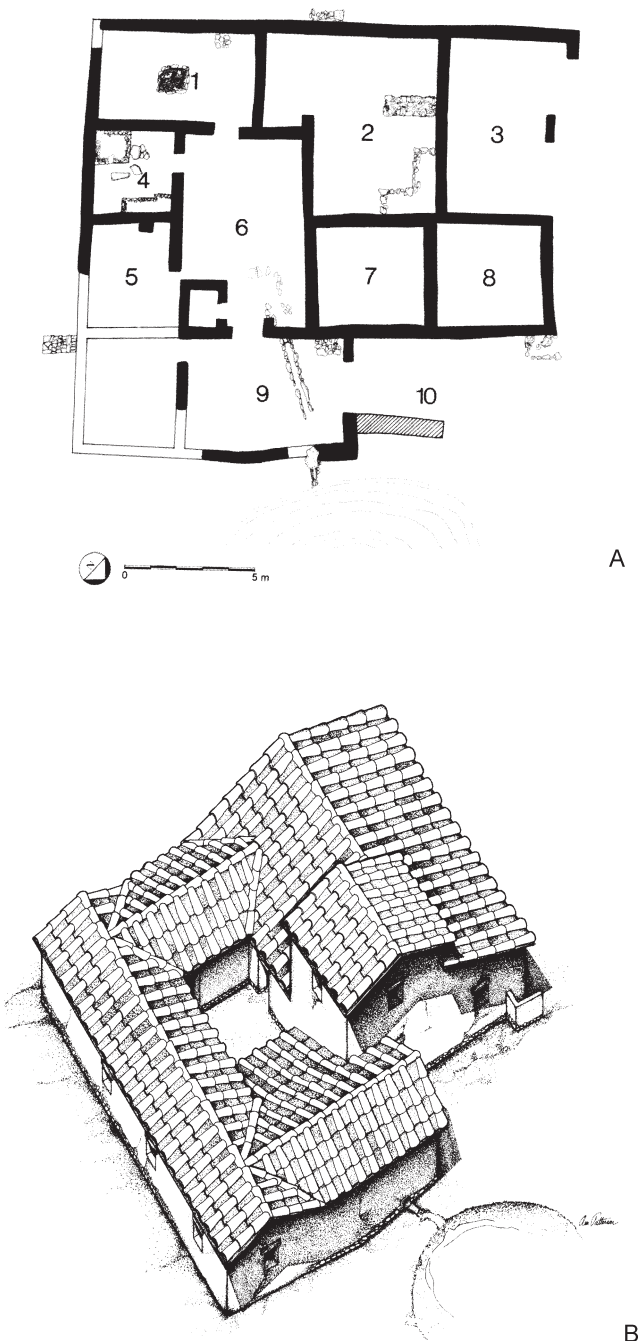

Fig. 23. Plan of Fattoria Stefan (Carter, 2006: 144–145, fig. 4.13 and 4.14).

flat agricultural lands of the upland of Lago del Lapo and the valley of the Venella (Carter, 2006: 138–139). The plan of this farmstead is rectangular, measuring 13.25 m × 16.50 m. It has three rows of rooms of a fairly uniform size. There is no direct evidence of a courtyard and neither of a second floor, although the width of the foundation (0.5 m) might suggest this

(Carter, 2006: 139). The rooms of the ground floor can be divided into domestic and workspaces.

Given the more or less complete amphorae found here, rooms 1 and 2 probably served for storage. In room 4 a hearth and the base of a cooking pot came to light, which means that this was a kitchen. Also room 9 was used for the preparation of food, because of the (“pelvis”-type) mortar found in the western corner. The remaining rooms could also have been used for domestic chores, or maybe for sleeping if there was no upstairs floor. The ceramics found in this farmstead comprise storage, kitchen and fine-ware vessels (Carter, 1990: 413). The Fattoria Fabrizio probably was a subsistence farm. It can be dated to the mid 4<sup>th</sup> century BC (Carter, 2006: 136).

Another well-preserved farmhouse in the Meta-pontino is the Fattoria Stefan at Lago del Lupo (fig. 23) (Carter, 2006: 143–146). It was situated on a prominent rise along the central dividing road of the *chora*. The farmstead measures 10.5 m × 18.3 m (Carter, 2006: 136). The plan includes an off-centre courtyard (room 6) with ten rooms rather loosely organized around it. Carter presumes that the farm grew by accretion in response to new needs, rather than having been built in one go, according to a unified plan (Carter, 2006: 146).

The hearth found in room 1 indicates that this room had the function of a kitchen (Carter, 2006: 143). Rooms 2 and 4 contained several basins and a platform for agricultural work, probably the processing of wine grapes. Also room 3 had an agricultural function as a stable, accessible only from the outside (Carter, 2006: 144). Room 6 was the courtyard. In room 7 a large number of loomweights were found. The ceramic assemblage consisted of many storage vessels together with considerable quantities of cooking, table and fine wares (Carter, 1980: 29). This demonstrates that the Fattoria Stefan was not only a production unit, but also intensively inhabited. This Hellenistic farmstead can be dated to the late 4<sup>th</sup> century BC.

The third Metapontine example is the farmhouse of the Pantanello sanctuary, dating from the late 4<sup>th</sup> to the early 3<sup>rd</sup> century BC (fig. 24) (Carter, 2006: 136, 167–168). This farmhouse was partly built over an earlier Archaic sanctuary, using its walls as foundation supports. The plan of the Pantanello farmstead does not resemble any of the preceding structures on the site, but is reminiscent of a farmhouse such as Fattoria Fabrizio (see fig. 21) (Carter, 2006: 168).

Its plan is rectangular, featuring nine rooms, and mea-

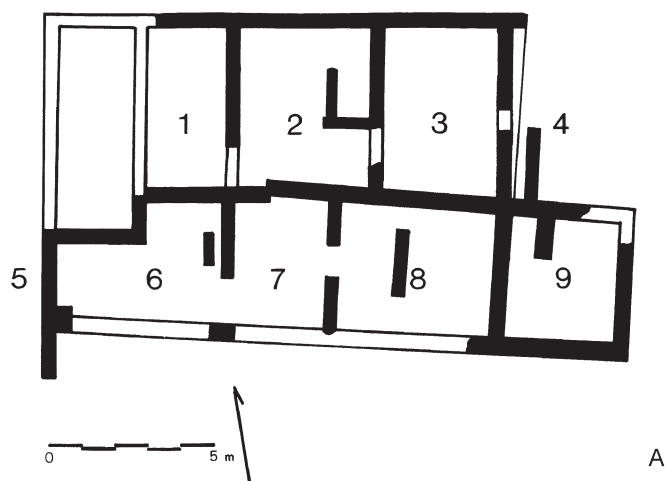
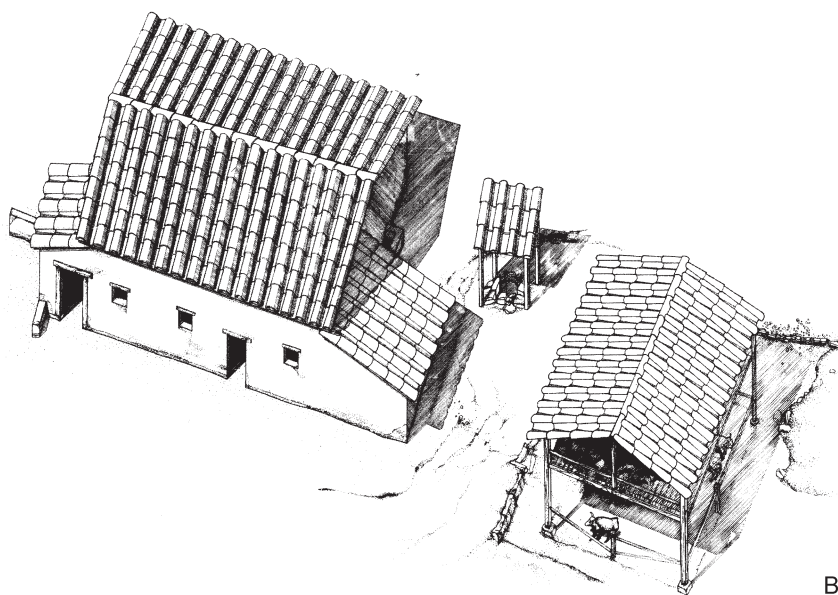

Fig. 24. Plan of Fattoria at Pantanello Sanctuary (Carter, 2006: 170–171, fig. 4.42 and 4.43).



tures approximately 10(?) m × 17.7 m (Carter, 2006: 170, fig. 4.42 and 136, table 4.A). The finds show that in a number of rooms agricultural activities took place. The kitchenware, the abundant fine, black gloss pottery and ample traces of hearths indicate which rooms were meant for daily living (Carter, 1992: 112). The cessation of the occupation of the farmstead is dated by the ceramics to the first half of the 3<sup>rd</sup> century BC (Carter, 2006: 168).

#### 4.4. Portieri in the light of the excavated farms of the Sibaritide and Metapontino

The examples mentioned above show that the average size of a Hellenistic farmstead, such as were

documented in the Sibaritide and the Metapontino, fits within the scatter of ceramics surveyed at Portieri. The concentration of ceramics at Portieri measures approximately 50 m × 50 m, so its plan can easily have been around 20 m × 20 m, like the examples from the Sibaritide and Metapontino discussed above. As we suggested earlier, the rocks piled up at the north of the site of Portieri (see fig. 4) will have belonged to the foundation of the building. Save for these rocks and tiles, no building material has been found. The Hellenistic farmsteads in the Metapontino are said to have been constructed of mudbrick walls that were set on a stone socle or foundation and with a roof made of tile over wooden framing (Carter, 2006: 137). This may have been the case at Portieri as well, but as mud-

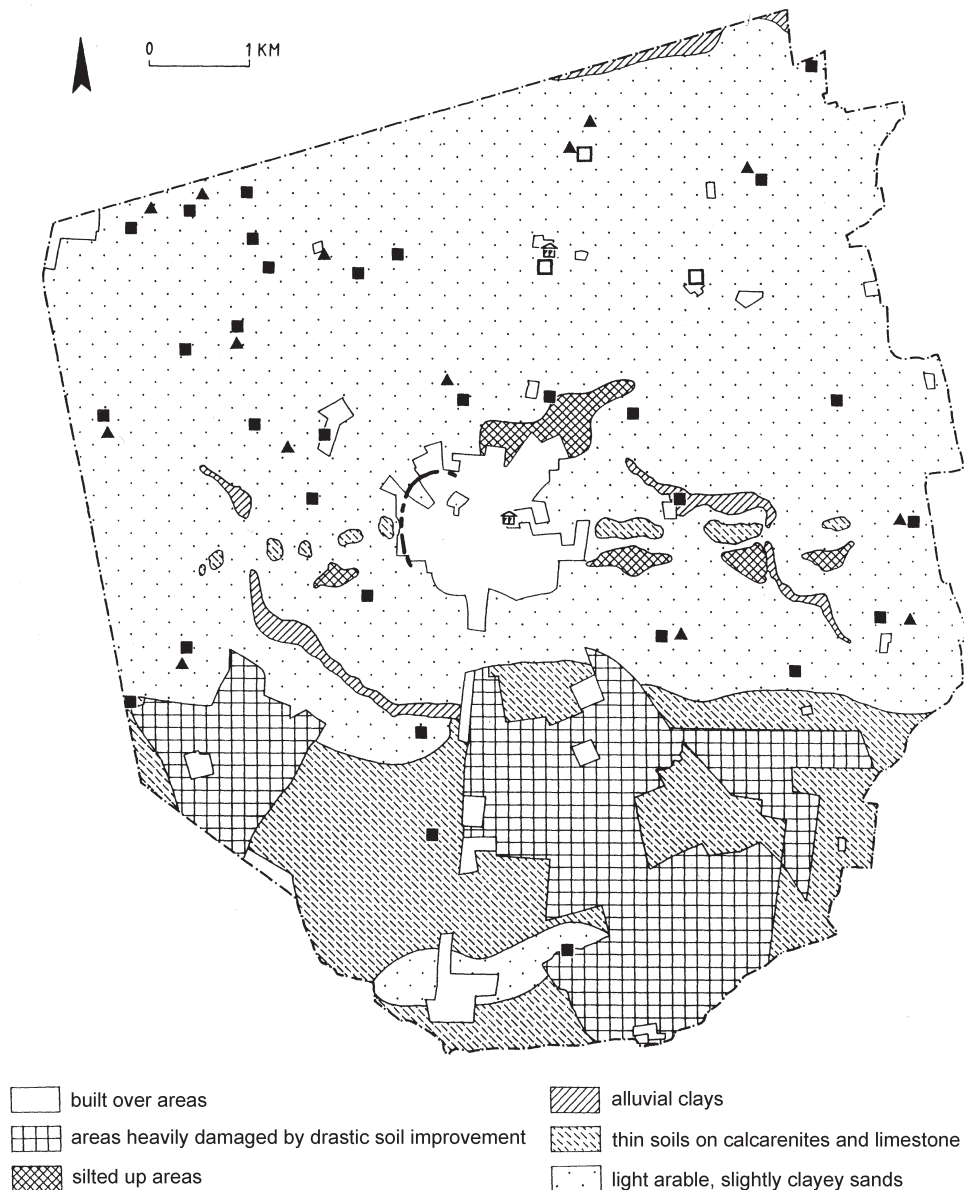

Fig. 25. Hellenistic sites in the *chora* of Oria (Yntema, 1993: 182, fig. 74).

brick and wood will not survive in the ploughsoil, we cannot be certain of this.

Furthermore, the assemblage of storage vessels, kitchenware, tableware and weaving utensils is characteristic for the Hellenistic farmsteads we have discussed. The ceramic assemblage of Portieri only partly complies with this, as weaving implements are lacking here. This may imply that Portieri was a farmstead specializing in the production of wine, an activity in which all inhabitants were involved. In the examples of farmsteads from the Sibaritide and the Metapontino no mention is made of exceptional quan-

tities of amphorae, while at Portieri relatively many amphora fragments have been found. However, the functional categories of pottery were not quantified in the site examples, so we lack a basis for a quantitative comparison.

#### 4.5. Portieri and rural expansion in the Hellenistic period

The date range of Portieri of 350–250 BC falls within the early Hellenistic phase. This phase is characterized by profound transformations of the landscape in

southern Italy. The hinterland of the colonies became more intensively inhabited than it had been in the previous periods.<sup>11</sup> In the Sibaritide this is clear from the increase in rural sites in the foothills as documented in the surveys by Quilici *et al.* (1969) and in the RAP surveys. The situation in the plain itself is not clear, as the ancient landscape is buried beneath a thick layer of sediments. Augerings carried out by the University of Pennsylvania and the Lerici foundation during the ‘search for Sybaris’, however, did produce evidence of rural occupation in the plain during the Hellenistic period.<sup>12</sup> Pending an analysis of the Hellenistic sites in the Sibaritide as part of the present research, we can for now only make some general assumptions on the basis of analogies with other southern Italian regions. Two well-investigated Hellenistic landscapes are the one around Oria in Apulia and the Metapontino.

In the Oria surveys most of the traced farms probably were single-family units, at times placed together in small clusters of two to four farmsteads, *i.e.* hamlets (Yntema, 1993: 181–194) (fig. 25). These hamlets could have been provided with small rural sanctuaries. Frequently, the hamlets and also the isolated farmsteads had their own rural cemetery (Yntema, 1993: 192). The presence of tombs close to the farmsteads indicates that the people inhabiting the countryside were closely connected to their rural dwellings. The evidence gathered during the fieldwork suggests that the isolated farms and the hamlets made their appearance quite suddenly in the Oria countryside (Yntema, 1993: 186).

In the Metapontino, the land of the *chora* was divided into relatively small, rectangular plots and each plot had only one – or in particular areas more than one – occupied farmhouse (Carter, 2006: 119) (fig. 26). All of the examples of the Metapontine farmhouses examined so far had space for work, living and storage (Carter, 2006: 148). In comparison with the Archaic period, the Hellenistic farmhouses took up an increasing amount of space in response to a growing demand for and range of agricultural products, including animals (Carter, 2006: 148). **The rapid increase of occupied farm sites in the *chora* was accompanied by a very large rise in the number of burials in the rural cemeteries (Carter, 2006: 227).**

In comparing the farmsteads in the Oria countryside with those in the Metaponto hinterland, parallels can be observed (Yntema, 1993: 193). The *chorae* of Metaponto and Oria both have hamlets (some with sanctuaries) as well as isolated farmsteads, and in both areas, settlements of both types can often be

shown to have had their own rural cemetery. A very distinctive feature of the *chora* of Metaponto is its regular layout of agricultural plots. Rural expansion accompanying urban development is commonly associated with a process of increase and intensification of agricultural production. This was certainly the case in the Sibaritide, as the site of Portieri shows; but closer analysis of all Hellenistic sites that have been found so far is needed before we can start to compare the Hellenistic rural landscape of the Sibaritide with Hellenistic landscapes elsewhere.

## 5. CONCLUSION AND FURTHER WORK

In the survey campaign of the Raganello Archaeological Project (RAP) in October 2004, evidence of a Hellenistic farmstead was found on the west bank of the Caldanelle river in the area of Portieri. The site was located on a small hilltop in a strategic position in the landscape and consisted of a scatter of ceramics of approximately 50 m × 50 m. The large amount of shards collected during the survey included

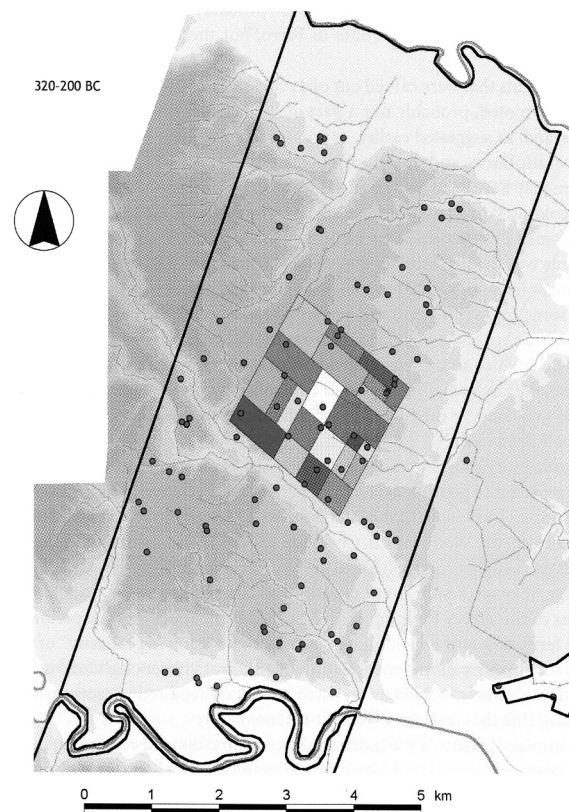

Fig. 26. Hellenistic sites in Bradano-Basento transect (320–200 BC) (Carter, 2006: 120, fig. 3.33).

fragments of many amphorae and black gloss ware, which makes this site stand out in comparison with other Hellenistic sites found during the surveys of the Groningen Institute of Archaeology (GIA). These sites either lack such materials or yielded only few shards of these ceramic categories. Besides the amphorae and the black gloss pottery, *ceramica comune* and roof tiles were found at Portieri. The ceramics provided a date for the site between approximately 350 and 250 BC, *i.e.* the early Hellenistic phase. Because of the relatively large amount of shards of wine amphorae, we may assume that we are dealing with a farmstead where wine was produced, stored and transported, to Thourioi among other places. The remaining categories of pottery indicate that the farmstead was inhabited all the year round.

In the Sibaritide and in the Metapontino, farmsteads have been excavated that may serve as parallels for the Portieri site. Like these farms, Portieri too may have had a plan of approximately 20 m × 20 m, having a foundation in local limestone with mudbrick walls on top and a tile-covered roof over wooden framing. In contrast to the ceramic categories identified at the excavated farmsteads, no loomweights were found at Portieri. This would underscore the observation that this farmstead specialized in wine production and that its residents were not involved in other activities, such as sheep rearing.

Like the well-investigated rural territories around Oria and Metaponto, the current research shows that the countryside of Thourioi too became more intensively inhabited than it had been in previous periods. Such expansion in general is associated with a process of increase and intensification of agricultural production.

Future work on the Hellenistic phase in the Sibaritide will comprise a functional and chronological analysis of all Hellenistic sites currently known in the territory of Thourioi. With this, a hierarchy of settlement sites can be established for the purpose of a thorough socio-economic interpretation of the rural patterns in the *chora* of Thourioi.

## 6. ACKNOWLEDGEMENTS

The first author is writing her PhD thesis on the Hellenistic sites and ceramics at the Groningen Institute of Archaeology of the University of Groningen. She would like to thank the following foundations for financial support: Fundatie van de Vrijvrouwe van Renswoude te 's-Gravenhage, Istituto Italiano di Cultura per i Paesi Bassi, Koninklijk Nederlands

Instituut te Rome, Philologisch Studiefonds, Prins Bernhard Cultuurfonds, Rijks Universiteit Groningen, Stichting Fonds Doctor Catharine van Tussenbroek en Stichting Jo Kolk Studiefonds. The authors are grateful to dott.ssa M. d'Andrea for comments on the text and ceramics, dr. P.M. van Leusen, E. Bolhuis and N. Hogan for editing the maps and P. van Ginneken, S. Boersma and M. Los-Weijns for the pottery drawings. M. Los-Weijns also compiled the plates in the catalogue.

## 7. NOTES

1. Sites 27 up to and including 30, in Quilici *et al.*, 1969.
2. Amphorae were not entered in the database as a separate class. The category of depurated ware includes the amphora fragments.
3. The first author followed the Italian system for the classification of ceramics, because most of the consulted literature is Italian. However, from the literature it is not always clear whether ceramics are assigned to a particular category because of their physical appearance (gloss or no gloss) or because of their function (dinner table or kitchen). In the classification of the Portieri ceramics, form has been given precedence over surface treatment and some jugs were therefore assigned to the black gloss category because of their form although they were probably not painted, and some possibly painted basins were allotted to the category of *ceramica comune* because of their function and similarity to other fragments.
4. They were also produced at Montegiordano (370/50–280 BC) and at Locri (mid-4<sup>th</sup> to mid-3<sup>rd</sup> century BC) (Vandermersch, 1994: 71–72).
5. Cup no. 41 was assigned to this category on account of the only parallel found for its form, although it seems quite large for a cup. (Nava & Osanna, 2001: No. 115 (85, 84, fig. 56), date: second quarter of the 4<sup>th</sup> century BC)
6. Catalogue no. 82, *cf.*: *Atti Lincei*, 1972: 208, No. 61 (CB 3504) (250, fig. 256), date: 4<sup>th</sup> century BC?, “*produzione locale con diffusione limitata*”.
7. The presence of craters, *skyphoi*, *oinochoai* and a *louterion* indicate that symposia were held, with the appropriate vessel forms. It has been observed that symposia may also have been held by indigenous households (Russo Tagliente, 1992: 198).
8. Local knowledge has it that “Portieri” means *porta* of the Sibaritide, in other words, the access from the mountains into the plain or the other way around; with this area functioning as a gateway (verbal communication by Antonio Larocca). This indicates an important function for this area, which presumably already existed in ancient times. Alternatively, *porta* may be interpreted as ‘small spur’ or ‘range of hills’.
9. According to Greco, towers on Greek farmsteads usually functioned as granaries. Among the few farmsteads excavated in

Magna Grecia, even small ones are found to have been provided with a tower (Greco, 2001: 193–194).

10. The *Fattoria di Stombi* presents many parallels for the pottery of Portieri, especially for the *skyphoi*, cups, amphorae, basins, mortars and cooking pots. However, its various ceramic categories were not quantified (*Atti Lincei*, 1988/89: 179–239).
11. Cf.: Oria survey (Yntema, 1993) and research in the Metapontino (Carter, 2006).
12. For a report on these augerings, see: Rainey and Lericci, 1967.

## 8. REFERENCES

- ATTEMA, P.A.J., VAN LEUSEN P.M. & P. RONCORONI (eds), 2006. *Il Progetto Archeologico Raganello, rapporto preliminare 2002–2003*, Associazione per la scuola internazionale “Lagaria” and Groningen Institute of Archaeology, Francavilla Marittima (CS).
- Atti della Accademia Nazionale dei Lincei, Notizie degli Scavi di Antichità*, vol. XXIII, suppl., 1969.
- Atti della Accademia Nazionale dei Lincei, Notizie degli Scavi di Antichità*, vol. XXIV suppl., 1970.
- Atti della Accademia Nazionale dei Lincei, Notizie degli Scavi di Antichità*, vol. XXVI suppl., 1972.
- Atti della Accademia Nazionale dei Lincei, Notizie degli Scavi di Antichità*, vol. XXVIII suppl., 1974.
- Atti della Accademia Nazionale dei Lincei, Notizie degli Scavi di Antichità*, vol. XLII–XLIII suppl., 1988/89.
- BARRA BAGNASCO, M. (ed.), 1989a. *Locri Epizefiri II. Gli insulati I2 e I3 dell'area di Centocamere*, Firenze, Casa Editrice Le Lettere.
- BARRA BAGNASCO, M. (ed.), 1989b. *Locri Epizefiri III, Cultura materiale e vita quotidiana*, Firenze, Casa Editrice Le Lettere.
- CARTER, J.C., 1980. A Classical Landscape. Rural Archaeology at Metaponto. *Archaeology* 33, 23–32.
- CARTER, J.C., 1990. Metapontum: Land, Wealth, and Population. In: *Greek Colonists and Native Populations, Proceedings of the First Australian Congress of Classical Archaeology*. Oxford, Clarendon press, 405–441.
- CARTER, J.C., 2006. *Discovering the Greek Countryside at Metaponto*. Ann Arbor, University of Michigan.
- COSTAMAGNA, L. & P. VISONÀ, 1999. *Oppido Mamertina. Ricerche Archeologiche nel territorio e in Contrada Mella*. Roma, Gangemi.
- GRECO, E., 1978. S. Maria del Cedro. Fraz. Marcellina. Loc. S. Bartolo (Cosenza). Scavi di un centro abitato di epoca ellenistica (1973; 1975). In: *Atti della Accademia Nazionale dei Lincei, Notizie degli Scavi di Antichità*, vol. XXXII. Roma, Accademia Nazionale dei Lincei, 429–459.
- GRECO, E., 2001. Abitare in campagna, *ACT XL* 2000. Taranto, 171–201.
- GRECO, E. 2003. Tra Sibari, Thurii e Copiae. Qualche ipotesi di lavoro. In: *Archeologia del Mediterraneo. Studi in onore di Ernesto De Miro*. Roma, L'Erma di Bretschneider, 369–374.
- GUALTIERI, M. & H. FRACCHIA, 1990. *Roccagloriosa I. L'abitato: scavo e ricognizione topografica* (1976–1986). Naples, Centre Jean Bérard.
- LEUSEN, P.M. VAN & N. RYAN, 2002. Educating the Digital Fieldwork Assistant. In: G. Burenhult, & J. Arvidsson (eds), *Archaeological Informatics: Pushing the Envelope – CAA2001 Computer Applications and Quantitative Methods in Archaeology* (BAR S1016). Oxford, Archaeopress.
- LEUSEN, P.M. VAN & P.A.J. ATTEMA, 2001/02. Regional archaeological patterns in the Sibaritide; preliminary results of the RPC field survey campaign 2000. *Palaeohistoria* 43/44, 397–416.
- MOLLO, F., 2003. *Ai confini della Brettia. Insediamenti e materiali nel territorio tra Belvedere Marittimo e Fuscaldo nel quadro del popolamento italico della fascia costiera tirrenica della provincia di Cosenza*. Rubbettino, Soveria Mannelli.
- MOREL, M. J.-P., 1981. *Céramique campanienne: les formes*. Rome, École Française de Rome.
- NAVA, M.L. & M. OSANNA (eds), 2001. *Rituali per una Dea Lucana. Il Santuario di Torre di Satriano*. Casa Editrice Cerbone, [S.l.].
- QUILICI, L., S. QUILICI-GIGLI, C. PALA & G.M. DE ROSSI, 1969. Carta Archeologica della Piana di Sibari, *Atti e Memorie della Società Magna Grecia*, Roma, A cura della Società di Magna Grecia.
- RAINEY, F.G. & C.M. LERICI, 1967. *The search for Sybaris: 1960 – 1965*. Roma, Lericci editori.
- RUSSO TAGLIENTE, A., 1992. *Edilizia Domestica in Apulia e Lucania, Ellenizzazione e Società nella tipologia abitativa indigena tra VIII e III secolo a.C.*, Galatina, Congedo editore.
- RUSSO, A., 1996. Le abitazioni degli indigeni: Problematiche generali. In: *Ricerche sulla casa in Magna Grecia e in Sicilia, Atti del colloquio*. Galatina, Congedo editore, 78–83.
- VANDERMERSCH, C., 1994. *Vins et amphores de Grande Grèce et de Sicile: IV–IIIe sec. avant J.-C.*, Naples, Centre Jean Bérard.
- YNTEMA, D., 1993. *In search of an ancient countryside*. PhD Thesis Amsterdam.
- YNTEMA, D.G., 2001. *Pre-Roman Valesio: excavations of the Amsterdam Free University at Valesio, province of Brindisi, southern Italy*. Amsterdam, Vrije Universiteit van Amsterdam/Institute of Archaeology.

## APPENDIX I: CATALOGUE OF CERAMIC MATERIAL

The ceramic material of the Portieri site has been divided into four functional categories: Amphora, Black Gloss, Ceramica Comune and Building Material. In the following, the terms and abbreviations used in the catalogue are explained, serving as an introduction to the catalogue. Descriptions are based on the method used by the Raganello Archaeological Project of the Groningen Archaeological Institute. Shards are referred to by:

*Ceramic Class Identifier*

This refers to the shard drawing. The letters AM stand for the Amphora category, BG for Black Gloss, CC for Ceramica Comune and BM for Building Material, followed by a sequence number (*e.g.* AM13)

*Shard number*

The shard number consists of the following (1-2-3-4):

1. Site code: POR (Portieri) with the year when found (04 or 05).
2. Unit number.
3. Bag number.
4. Individual shard number.

Each entry is followed by a description of the shard as to:

*Shape*

For every shard, the shape of the profile of base, body, neck, rim and lip is described, for handles the shape of the section is added. Where present, surface features such as handle attachments, decorations, grooves or ridges are described as well.

*Colour*

A Munsell-value is noted for the surface colour (exterior and interior, respectively ext. and int.), the core colour and, if applicable, the innercore colour (using the Munsell chart of 2000). For the fragments with clear traces of black gloss, the slip colour is mentioned separately from the surface clay colour.

*Measurements*

Measurements are given for every shard in the following order:

- height x length (x width)
- thickness base/ wall/ lip
- section (handle)
- diameter

*Comments*

Special features are noted here and reference is made to comparable fragments in the catalogue. Further, the condition of the shards is mentioned whether worn, slightly worn or with fresh breaks.

*Clay*

For the amphora fragments the clay has been categorized into coarse ware A (only small inclusions), coarse ware B (large inclusions), coarse ware C (sandy inclusions) and depurated clay. The clay used for black gloss pottery, ceramica comune or building material is either depurated or coarse.

*Parallels*

For the amphora fragments the descriptions of Vandermersch (1994) for MGS III and MGS IV have been used for the classification of the amphora pieces and no further reference was deemed necessary to parallels at other sites. Parallels found in the literature for the black gloss pottery and ceramica comune are referred to by bibliographical references as listed below. For some of the parallels the location of production (*i.e.* "prod."; *e.g.* Campania) is mentioned (in the sources) and whether a proto-type is known (*i.e.* "origin"; *e.g.* Attic).

The following abbreviations are used in the parallels:

- Locri II:** Barra Bagnasco, M. (ed), 1989. *Locri Epizefiri II. Gli insulati 12 e 13 dell'area di Centocamere*. Firenze, Casa Editrice Le Lettere, 188–190.
- Mollo 2003:** Mollo, F., 2003. *Ai confini della Brettia. Insediamenti e materiali nel territorio tra Belvedere Marittimo e Fuscaldo nel quadro del popolamento italico della fascia costiera tirrenica della provincia di Cosenza*. Rubbettino, Soveria Mannelli.
- Morel:** Morel, M.J.-P., 1981. *Céramique campanienne: les formes*. Rome, École Française de Rome.
- Oppido Mamertina:** Costamagna, L. & P. Visonà, 1999. *Oppido Mamertina. Ricerche Archeologiche nel territorio e in Contrada Mella*. Roma,
- Rocagloriosa I:** Gualtieri, M. & H. Fracchia, 1990. *Rocagloriosa I. L'abitato: scavo e ricognizione topografica* (1976–1986). Naples, Centre Jean Bérard.
- S.Maria del Cedro:** Greco, E., 1978. "S. Maria del Cedro. Fraz. Marcellina. Loc. S. Bartolo (Cosenza). Scavi di un centro abitato di epoca ellenistica



(1973; 1975).” In: *Atti della Accademia Nazionale dei Lincei, Notizie degli Scavi di Antichità*, Serie ottava – vol. XXXII. Roma, Accademia Nazionale dei Lincei, 429–459.

**Atti Lincei 1970:** *Atti della Accademia Nazionale dei Lincei, Notizie degli Scavi di Antichità*, vol. XXIV suppl., 1970.

**Atti Lincei 1972:** *Atti della Accademia Nazionale dei Lincei, Notizie degli Scavi di Antichità*, vol. XXVI suppl., 1972.

**Atti Lincei 1974:** *Atti della Accademia Nazionale dei Lincei, Notizie degli Scavi di Antichità*, vol. XXVIII suppl., 1974.

**Atti Lincei 1988/89:** *Atti della Accademia Nazionale dei Lincei, Notizie degli Scavi di Antichità*, vol. XLII–XLIII suppl., 1988/89.

**Torre di Satriano:** Nava, M.L. & M. Osanna (eds), 2001. *Rituali per una Dea Lucana. Il Santuario di Torre di Satriano*. Casa Editrice Cerbone, [S.l.].

**Yntema 2001:** Yntema, D.G., 2001. *Pre-Roman Valesio: excavations of the Amsterdam Free University at Valesio, province of Brindisi, southern Italy*. Amsterdam, Vrije Universiteit van Amsterdam/Institute of Archaeology.

#### AMPHORAE/RIM FRAGMENTS [SEE PLATES I–IV]

##### TYPE 1: SLIGHTLY OUTCURVED

###### AM1

POR04-4769-12-18

slightly outcurved rim, flattened lip which is thickened on the outside

ext. and int.: reddish yellow 5YR between 6/6 and 6/8, core: red 2.5YR 6/6

3.7×6.7×0.6(wall) - 1.7(lip), D 15

soft clay

coarse ware A

###### AM2

POR04-4769-04-05

slightly outcurved rim, flattened lip which is thickened on the outside

ext. and int.: reddish yellow 5YR between 6/6 and 6/8, core: red 2.5YR 6/6

2.5×8.8×0.7(wall) - 2.0(lip), D 15

fresh breaks

coarse ware A

###### AM3

POR04-4770-04-07

slightly outcurved rim, flattened lip which is thickened on the outside

ext. and int.: reddish yellow 7.5YR 7/6, core: reddish yellow 5YR 7/6

2.4×6.6×0.9(wall) - 2.3(lip), D 15

fresh breaks, clay colour yellower than other amphora rims in this catalogue

depurated clay

###### AM4

POR04-4768-01-04

slightly outcurved rim, flattened lip which is thickened on the outside

ext. and int.: reddish yellow 5YR between 6/6 and 6/8, core: red 2.5YR 6/6

2.8×5.2×0.6(wall)-2.0(lip), D 14

fresh breaks

coarse ware A

###### AM5

POR04-4769-08-15 & POR04-4769-12-16

slightly outcurved rim, flattened lip which is thickened on the outside

ext. and int.: reddish yellow 5YR between 7/6 and 6/6, core: red 2.5YR 6/6

3.2×13.9×0.5(wall) - 2.1(lip), D 15

fresh breaks

coarse ware A

###### AM6

POR04-4769-09-18

slightly outcurved rim, flattened lip which is thickened on the outside

ext. and int.: reddish yellow 5YR between 7/6 and 6/6, core: red 2.5YR 6/6

3.0×11.0×0.7(wall) - 2.2(lip), D 17

fresh breaks

coarse ware A

###### AM7

POR04-4769-08-14

slightly outcurved rim, flattened lip which is thickened on the outside and slightly undercut

ext. and int.: reddish yellow 5YR 6/6, core: red 2.5YR 6/6

5.7×11.1×0.6(wall) - 2.5(lip), D 16  
fresh breaks  
coarse ware A

**AM8**

POR04-4769-09-17 & POR04-4769-09-23  
slightly outcurved rim, flattened lip which is thickened on the outside and slightly undercut  
ext. and int.: reddish yellow 5YR 6/8, core: reddish yellow 5YR 6/6

5.1×10.2×0.9-0.6(wall) - 2.2 (lip), D 15  
fresh breaks  
coarse ware A

**AM9**

POR04-4769-11-09  
slightly outcurved rim, flattened lip which is thickened on the outside and slightly undercut  
ext. and int.: reddish yellow 5YR between 6/8 and 7/8, core: red 2.5YR 6/8, inner core: 2.5YR 6/6  
3.7×6.2×0.6(wall) - 2.1(lip), D 16  
fresh breaks  
coarse ware A

TYPE 2: OUTCURVED

**AM10**

POR04-4769-02-03  
outcurved rim, flattened lip which is thickened on the outside and slightly undercut  
ext. and int.: reddish yellow 5YR between 7/6 and 6/6, core: red 2.5YR 6/6  
3.5×9.1×0.8(wall) - 2.3(lip), D 18  
fresh breaks  
coarse ware A

**AM11**

POR04-4770-06-26  
outcurved rim, flattened lip which is thickened on the outside  
ext. and int.: reddish yellow 5YR between 7/6 and 6/6, core: red 2.5YR 6/6  
3.0×5.5×0.7(wall) - 2.1(lip), D c.14  
fresh breaks  
coarse ware A

**AM12**

POR04-4769-01-03 & POR04-4769-11-10  
outcurved rim, flattened lip which is thickened on the outside  
ext. and int.: reddish yellow 5YR between 6/8 and 7/8, core: red 2.5YR 6/8, inner core: red 2.5YR 6/6  
2.7×11.6×0.7(wall) - 2.3(lip), D 18  
fresh breaks  
coarse ware A

**AM13**

POR04-4769-04-08 & POR04-4769-11-11  
outcurved rim, flattened lip which is thickened on the outside  
ext. and int.: reddish yellow 5YR between 6/6 and 6/8, core: red 2.5YR 6/6, inner core: weak red 2.5YR 6/4  
2.7×10.0×0.7(wall) - 2.0(lip), D 16  
fresh breaks  
coarse ware A

**AM14**

POR04-4770-06-24  
outcurved rim, flattened lip which is thickened on the outside and slightly undercut  
ext. and int.: reddish yellow 5YR 6/6, core: red 2.5YR 6/6  
5.6×12.8×0.7(wall) - 2.1(lip), D 15  
fresh breaks  
coarse ware A

**AM15**

POR04-4769-10-22  
outcurved rim, flattened lip which is thickened on the outside and slightly undercut  
ext. and int.: reddish yellow 5YR between 7/6 and 6/6, core: red 2.5YR 6/6  
4.0×6.1×0.7(wall) - 1.9(lip), D 15  
fresh breaks  
coarse ware A

**AM16**

POR04-4770-06-27  
outcurved rim, flattened lip which is thickened on the outside and slightly undercut  
ext. and int.: reddish yellow 5YR between 6/6 and 6/8, core: red 2.5YR 6/6, inner core: light reddish brown 5YR 6/4  
3.3×5.8×0.9(wall) - 2.4(lip), D 17  
fresh breaks  
coarse ware A

**AM17**

POR04-4769-09-21  
outcurved rim, flattened lip which is thickened on the outside and slightly undercut  
ext. and int.: reddish yellow 5YR between 6/6 and 6/8, core: red 2.5YR 6/6  
2.8×7.3×0.8-0.6(wall) - 1.9(lip), D 15  
fresh breaks  
coarse ware A

**AM18**

POR04-4769-12-15  
outcurved rim, flattened lip which is thickened on the outside and slightly undercut  
ext. and int.: reddish yellow 5YR between 7/6 and 6/6, core: red

2.5YR 6/6  
3.5×13.6×0.6(wall) - 1.9(lip), D 17  
finger imprints visible on the exterior, fresh breaks  
coarse ware A

**AM19**

POR04-4770-03-05  
outcurved rim, flattened lip which is thickened on the outside and slightly undercut  
ext. and int.: reddish yellow 5YR between 6/6 and 6/8, core: red 2.5 YR 6/6, slip on int.: reddish yellow 7.5YR  
3.1×9.7×0.9(wall) - 2.2(lip), D 17  
fresh breaks  
coarse ware A

**AM20**

POR04-4770-06-29  
outcurved rim, flattened lip which is thickened on the outside and very slightly undercut  
ext. and int.: reddish yellow 5YR between 6/6 and 7/6, core: light reddish brown 5YR 6/4  
2.6×3.8×0.7(wall) - 1.5/1.6(lip), D 12? (irregular)  
fresh breaks  
coarse ware A

**AM21**

POR04-4769-09-16  
outcurved rim, flattened lip which is thickened on the outside and slightly undercut  
ext. and int.: reddish yellow 5YR 6/6, core: red 2.5YR 6/6, inner core: brown 7.5YR 5/2  
3.5×11.0×0.8(wall) - 2.2(lip), D 16  
fresh breaks  
coarse ware A

**AM22**

POR04-4769-10-23  
flattened lip which is thickened on the outside  
ext. and int.: reddish yellow 5YR 6/8, core: red 2.5YR 6/6  
2.3×8.0×0.6-2.4(lip), D c.18  
fresh breaks  
coarse ware A

**AM23**

POR04-4770-01-16  
outcurved rim, flattened lip which is thickened on the outside  
ext. and int.: reddish yellow 5YR 6/6, core: red 2.5YR 6/6  
2.5×7.3×0.9(wall) - 1.7(lip), D 17  
fresh breaks  
coarse ware A

**AM24**

POR04-4770-05-15

flattened lip which is thickened on the outside  
ext. and int.: reddish yellow 5YR between 6/6 and 6/8, core: red 2.5YR 6/6  
2.8×6.4×0.9-2.3(lip), D 17  
fresh breaks  
coarse ware A

**AM25**

POR04-4768-01-01  
flattened lip which is thickened on the outside  
ext. and int.: reddish yellow 5YR between 6/6 and 6/8, core: red 2.5YR 6/6  
3.2×8.4×0.4-2.0(lip), D 18  
fresh breaks  
coarse ware A

**AM26**

POR04-4769-03-01  
lip which is thickened on the outside and with horizontal depression  
ext. and int.: very pale brown 10YR 7/4, core: reddish yellow 5YR 7/6  
1.9×6.5×0.4-1.7(lip), D c.15  
fresh breaks  
depurated clay

**AM27**

POR04-4770-01-17  
outcurved rim, flattened lip which is thickened on the outside and slightly undercut  
ext. and int.: reddish yellow 5YR between 6/6 and 6/8, core: red 2.5YR 6/6  
2.1×6.0×0.7(wall) - 2.0(lip), D c.14  
fresh breaks  
coarse ware A

SUBTYPE OF TYPE 2: DECORATED WITH RIDGE

**AM28**

POR04-4769-12-17  
outcurved rim, flattened lip which is thickened on the outside and slightly undercut, horizontal encircling ridge just below rim  
ext. and int.: reddish yellow 7.5YR between 7/6 and 6/6, core: red 2.5YR 6/6  
4.1×7.0×0.9-0.7(wall) - 1.9(lip), D 16  
fresh breaks  
coarse ware A

**AM29**

POR04-4769-03-06  
outcurved rim, flattened lip which is thickened on the outside and slightly undercut, horizontal encircling ridge just below rim  
ext. and int.: reddish yellow 5YR between 6/6 and 6/8, core: red

2.5YR 6/6

4.0×6.4×0.9(wall) - 1.9(lip), D c.15

fresh breaks

coarse ware B

**AM30**

POR04-4770-01-12

outcurved rim, flattened lip which is thickened on the outside and

slightly undercut, horizontal encircling ridge just below rim

ext. and int.: reddish yellow 5YR between 7/6 and 6/6, core: red

2.5YR 6/6

4.3×9.1×0.7(wall) - 2.1(lip), D 16

fresh breaks

coarse ware A

TYPE 3: OUTTURNED

**AM31**

POR04-4769-06-08

outturned rim, flattened lip which is thickened on the outside and

very slightly undercut, part of handle attachment on exterior of neck

ext. and int.: reddish yellow 5YR between 6/8 and 7/8, core: red

2.5YR 6/6

5.4×8.4×0.7-0.5(wall) - 2.1(lip), D 17

fresh breaks

coarse ware A

**AM32**

POR04-4771-01-08

outturned rim, flattened lip which is thickened on the outside and

slightly undercut

ext. and int.: reddish yellow 5YR between 6/6 and 6/8, core: red

2.5YR 6/6

3.5×8.1×0.7(wall) - 1.8(lip), D 16

fresh breaks

coarse ware A

EXCEPTION

**AM33**

POR04-4769-05-06

flattened lip which is thickened on the outside, decoration of horizontal incised line on exterior

ext. and int.: reddish yellow 5YR between 6/6 and 6/8, core: red

2.5YR 6/6

3.1×7.1×1.1-2.2(lip), D 16

fresh breaks

coarse ware C

**HANDLE FRAGMENTS [SEE PLATE IV]**

TYPE 1: BENDS DIRECTLY DOWNWARDS

**AM34**

POR04-4769-09-27 & 4769-10-27

vertical band-handle, in section oval, with very small part of neck

ext. and int.: reddish yellow 5YR 7/6, core: red 2.5YR 6/6

13.2×4.0×2.0

fresh breaks

coarse ware A

**AM35**

POR04-4769-06-12

vertical band-handle, in section rounded oval, with small part of neck

ext. and int.: reddish yellow 5YR between 7/6 and 6/6, core: red

2.5YR 6/6

6.2×4.0×2.2

fresh breaks

coarse ware A

TYPE 2: SLIGHTLY CURVED UPWARDS

**AM36**

POR04-4769-04-10

vertical band-handle which is slightly curved upwards, in section rounded oval, with small part of neck

ext. and int.: very pale brown 10YR 7/4, core: reddish yellow

7.5YR 7/6

5.0×4.6×2.1

fresh breaks, soft material

depurated clay

WITH FINGER IMPRINT

**AM37**

POR04-4769-01-06

vertical band-handle, in section rounded oval, with small part of the shoulder, finger imprint on attachment at shoulder visible

ext.: reddish yellow 5YR 6/6, int.: light reddish brown 5YR 6/4, core: red 2.5YR 6/6

11.7×3.9×2.5

fresh breaks

coarse ware A

**SPIKES [SEE PLATE V]**

TYPE 1: CONVEX 1

**AM38**

POR04-4769-07-03

convex base, inside concave

ext. and int. and core: reddish yellow 5YR 6/8, inner core: weak red 2.5YR 6/4  
6.3×4.9×2.2(base)-0.8(wall), D c. 3.0  
fresh breaks  
coarse ware A

TYPE 2: CONVEX 2

#### AM39

POR04-4769-09-45  
convex base, inside concave  
ext.: reddish yellow 5YR between 6/6 and 6/8, int.: reddish yellow 5YR 6/6, core: red 2.5YR 6/6  
7.5×3.4×1.1-0.5(wall), D c. 3.0  
some fresh breaks  
coarse ware A

TYPE 3: RAISED 1

#### AM40

POR04-4770-06-35  
raised almost flat base, inside concave  
ext.: reddish yellow 5YR between 6/6 and 6/8, int.: reddish yellow 5YR 6/6, core: red 2.5YR 6/6  
9.0×9.5×1.1(base)-0.9(wall), D 3.3  
fresh breaks  
coarse ware A

TYPE 4: RAISED 2

#### AM41

POR04-4769-11-23  
raised almost flat base, inside convex  
ext. and int.: reddish yellow 5YR 6/6, core: reddish yellow 5YR 6/6  
3.4×3.2×1.0(base)-0.6(wall), D c. 3.0  
fresh breaks  
coarse ware A

### BLACK GLOSS/OPEN FORMS

#### PLATE/RIM [SEE PLATE V]

#### BG1

POR04-4770-06-07  
incurved rim, convex lip which is thickened on the outside  
ext. and int.: reddish yellow 5YR 6/6, core: pale red 2.5YR 7/4  
1.5×2.9×0.4(wall)-0.5(lip), D c.45  
slightly worn  
depurated clay  
Mollo, 2003: No. C119 (p. 221; p. 434, Tav. LXVIII), date: end of 4<sup>th</sup>-beg. 3<sup>rd</sup> c. BC, found at Cetraro (CE16) (see Morel, 2283-2286)

#### BG2

POR04-4769-11-28  
incurved rim, convex lip which is thickened on the outside  
ext. and int.: reddish yellow 5YR 7/6, core: weak red 2.5YR 6/4  
1.3×3.5×0.6(wall)-0.9(lip), D c.30  
almost no traces of black gloss preserved, worn  
depurated clay  
Morel no. 2236 a 1(?) (p. 151; Pl. 37), date: probably 3<sup>rd</sup> c. BC, prod.: South or Mid-South Italy

#### BG3

POR04-4768-01-08  
flaring wall, convex lip which is thickened on the outside  
ext. and int.: light brown 7.5YR 6/4, core: pinkish gray 7.5YR 6/2  
1.0×4.0×0.4(wall)-0.8(lip), D c.32  
worn  
depurated clay  
Morel no. 2234-2258 (p. 150-151; Pl. 37-38), date: probably 3<sup>rd</sup> c. BC

#### BG4

POR04-4769-09-32  
incurved rim with convex lip  
ext. and int.: reddish yellow 5YR 7/6, core: red 2.5YR 6/6  
2.0×3.8×0.4(wall)-0.4(lip), D c.35?  
slightly worn  
depurated clay  
Mollo, 2003: No. C118? (p. 221; p. 434, Tav. LXVIII), date: 350/325-250 BC, found at Cetraro (CE06) (see Morel, 2283-2286)

#### BG5

POR04-4770-07-22  
flaring wall, straight rim, flattened lip  
ext. and int.: reddish yellow 5YR between 7/6 and 6/6, core: red 2.5YR 6/6, gloss: black 5YR 2.5/1  
0.9×2.0×0.3(wall)-0.4(lip), D c.10  
worn  
depurated clay  
Morel no. 2237 a 2 (p. 151; Pl. 38), date: end 4<sup>th</sup> c. BC, prod.: South-Italy, especially Apulia; *Atti Lincei*, 1988/89: 191, No. 39 (St. 1629) (p. 212, fig. 212), date: 4<sup>th</sup>-3<sup>rd</sup> c. BC

#### BG6

POR04-4770-07-21  
flaring wall, straight rim, flattened lip which is thickened on the outside  
core: light red 2.5YR 7/8, gloss: black 5YR 2.5/1  
0.9×2.8×0.3(wall)-0.5(lip), D c.12?  
fresh breaks  
depurated clay  
Morel no. 2237 a 2 (p. 151; Pl. 38), date: end of 4<sup>th</sup> c. BC, prod.: South-Italy, especially Apulia; *Atti Lincei*, 1988/89: 187, No. 23 (St. 328) (p. 211, fig. 211), date: end 4<sup>th</sup>-beg. 3<sup>rd</sup> c. BC

**BG7**

POR04-4770-07-23

flaring wall, straight rim, flattened lip which is thickened on the outside

ext. and int.: light brown 7.5YR 6/3, core: reddish yellow 5YR 6/6, gloss: black 5YR 2.5/1

1.3×1.8×0.3(wall)-0.4(lip), D c.8?

worn

depurated clay

Morel no. 2237 a 2 (p. 151; Pl. 38), date: end 4<sup>th</sup> c. BC, prod.: South-Italy, especially Apulia**BG8**

POR04-4769-11-48

incurved wall, straight rim, flattened lip

ext. and int.: reddish yellow 5YR between 7/6 and 6/6, core: red 2.5YR 6/6, gloss: dusky red 2.5YR 3/2

0.9-1.9×0.3(wall)-0.3(lip), D c.10

slightly worn

depurated clay

Rocagloriosa I no. 134 (p. 247; p. 248, fig. 181), date: end 4<sup>th</sup> - beg. 3<sup>rd</sup> c. BC**BG9**

POR04-4769-08-20

flaring wall, straight rim, convex lip which is thickened on the outside

ext. and int.: reddish yellow 5YR between 7/6 and 6/6, core: red 2.5YR 6/6, gloss: black 5YR 2.5/1

0.8×2.0×-.2(wall)-0.4(lip), D 7-10

fresh breaks

depurated clay

Rocagloriosa I no. 140 (p. 249; p. 248, fig. 181), date: early to late 3<sup>rd</sup> c. BC**BG10**

POR04-4770-06-38

outturned rim, convex lip which is thickened on the outside

ext. and int.: reddish yellow 5YR between 7/6 and 6/6, core: red 2.5YR 6/8, gloss: black 5YR 2.5/1

1.9×5.0×0.7-0.9(wall)-1.2(lip), D c. 36

same type as 4770-07-20 and 4770-06-37; fresh breaks

depurated clay

no parallel found yet

**BG11**

POR04-4770-07-19

straight rim, convex lip which is thickened on the outside

ext. and int.: reddish yellow 5YR 6/6, core: reddish yellow 5YR 7/8, gloss: black 5YR 2.5/1

1.1×4.2×0.8(wall)-1.1(lip), D c.36

probably same type as POR04-4770-06-38, POR04-4770-07-20 and POR04-4770-06-37; worn

depurated clay

no parallel found yet

**PLATE/BASE [SEE PLATE VI]****BG12**

POR04-4769-09-12

flaring base ring, rounded edge, outside convex, inside concave

ext. and int.: reddish yellow 5YR between 6/6 and 6/8, core: red 2.5YR 6/6

3.4×9.1×0.6(base)-0.7(wall), D c.11

almost no traces of black gloss preserved, fresh breaks

depurated clay

Morel no. 1271 b 1 ? (p. 100; Pl. 10), date: c. 320-275 BC

**BG13**

POR04-4769-02-11 &amp; POR04-4770-02-07

flaring base ring, slightly faceted edge, outside convex, inside concave

ext. and int.: reddish yellow 5YR 7/6, core: red 2.5YR 6/6

1.8×4.2×0.4(base)-0.4(wall), D c.11

fresh breaks

depurated clay

Locri II no. 218 (p. 199; Tav. XXVIII, XXXIV), date: c. 3<sup>rd</sup> c. BC (see Morel P321c)**BG14**

POR04-4770-06-52

almost upright base ring, rounded edge, outside convex, inside concave, horizontal groove on inside of ring

ext. and int.: reddish yellow 5YR between 7/6 and 6/6, core: red 2.5YR 6/6, gloss: black 5YR 2.5/1

1.9×5.0×0.7(base)-0.4(wall), D 5.5

fresh breaks

depurated clay

Mollo, 2003: No. C121 (p. 221-222; p. 435, Tav. LXIX), date: 350/325-250 BC, found at Cetraro (CE06)

**BG15**

POR04-4770-02-14 &amp; POR04-4769-11-61

almost upright base ring, rounded edge, inside concave

ext.: reddish yellow 5YR 7/6, core: reddish yellow 5YR 6/6, gloss: black 5YR 2.5/1

1.5×5.2×0.4(base)-0.4(wall), D 5

fresh breaks

depurated clay

Mollo, 2003: No. C124? (p. 222; p. 435, Tav. LXIX), date: Hellenistic, found at Cetraro (CE10)

**BG16**

POR05-4769-13-15

flaring base ring, slightly faceted edge, outside convex, inside concave

ext. and int.: reddish yellow 5YR 7/6, core: light brown 7.5YR 6/3, inner core: red 2.5YR 6/6  
 1.5×3.9×0.3(base)-0.4(wall), D 11  
 fresh breaks  
 deperated clay  
 Oppido Mamertina no. 524? (p. 289; p. 288, fig. 301) (refers to Morel no. P212b, date: 200-175 BC)

**BOWL/RIM [SEE PLATES VI–VII]****BG17**

POR04-4770-02-03  
 outcurved rim, convex lip which is thickened on the outside  
 ext. and int.: reddish yellow 5YR 6/6, core: red 2.5YR 6/6  
 1.7×4.6×0.3(wall)-0.7(lip), D 12  
 worn  
 deperated clay  
 Rocca glorioiosa I no. 130a? (p. 246; 242, fig. 180), date: 4<sup>th</sup>-3<sup>rd</sup> c. BC (exist many small variations)

**BG18**

POR04-4770-04-08  
 outcurved rim, convex lip which is thickened on the outside  
 ext. and int.: reddish yellow 5YR 7/6, core: red 2.5YR 6/6  
 1.2×2.9×0.5(wall)-1.0(lip), D 20-23  
 worn  
 deperated clay  
 Rocca glorioiosa I no. 130b? (p. 246; p. 242, fig. 180), date: early 3<sup>rd</sup> c. BC, probably second quarter

**BG19**

POR04-4769-03-02  
 outcurved rim, convex lip which is thickened and faceted on the outside  
 ext. and int.: reddish yellow 5YR 7/6, core: red 2.5YR 6/6  
 1.5×3.3×0.6(wall)-0.7(lip), D c.18  
 Slightly worn  
 Deperated clay  
 most similar: Morel no. 1271 b 1 (p. 100; Pl. 10), date: 320-275 BC

**BG20**

POR04-4770-01-02  
 upright rim, overhanging convex lip which is thickened on the outside  
 ext. and int.: reddish yellow 5YR 7/6, core: light red 2.5YR 7/6  
 1.1×3.2×0.4(wall)-1.4(lip), D c.20  
 worn  
 deperated clay  
 Morel no. 1552 a 1(?) (p. 123; Pl. 23), date: 350-325 BC, prod.: South-Campania

**BG21**

POR04-4769-11-36  
 incurved rim, pointed lip with rounded thickening on the outside and undercut  
 ext.: reddish yellow 5YR 7/6 and 7.5YR 7/6, int.: reddish yellow 5YR 7/6, core: reddish yellow 5YR 6/6  
 2.2×7.4×0.5(wall) - 0,2-1.4(lip), D 26  
 fresh breaks  
 deperated clay  
 Morel no. 2538? (p. 180-181; Pl. 54), date: ca 3<sup>rd</sup> c. BC, origin: North-Italy

**BG22**

POR04-4770-07-05  
 incurved rim, convex lip which is thickened on the in- and outside and undercut on the outside  
 ext.: reddish yellow 5YR 7/6, int.: light reddish brown 5YR 6/4, core: weak red 2.5YR 6/4  
 1.6×4.5×0.3(wall) - .4(lip), D 30  
 fresh breaks  
 deperated clay  
 Morel no. 2538? (p. 180-181; Pl. 54), date: c. 3<sup>rd</sup> c. BC, origin: North-Italy

**BG23**

POR04-4769-11-24  
 slightly incurved rim, flattened lip which is thickened on the outside  
 ext. and int.: reddish yellow 5YR between 6/6 and 7/6, core: red 2.5YR 6/6  
 3.8×7.6×0.4(wall)-1.1(lip), D 25  
 fresh breaks  
 deperated clay  
 Morel no. 2538 (p. 180-181; Pl. 54), date: 3<sup>rd</sup> c. BC, prod.: North-Italy

**BG24**

POR04-4770-04-10  
 incurved rim, convex lip which is thickened on the in- and outside  
 ext. and int.: reddish yellow 5YR 7/8, core: reddish yellow 5YR 6/6  
 2.1×4.6×0.3(wall)-1.1(lip), D 18  
 fresh breaks  
 deperated clay  
 Morel no. 2538? (p. 180-181; Pl. 54), date: in 3<sup>rd</sup> c. BC, prod.: North-Italy

**BG25**

POR04-4769-11-29  
 flaring wall, straight rim, convex lip which is thickened on the outside  
 ext.: from light red 2.5YR 7/6 to pale red 2.5YR 7/4, int.: weak red 2.5YR 6/4, core: pale red 2.5YR 7/4  
 1.2×2.1×0.2(wall)-0.7(lip), D 12-14

worn  
depurated  
no parallel found yet

**BG26**

POR05-4769-13-09

flaring wall, slightly incurved rim, convex lip  
ext. and int.: from red 2.5YR 6/6 to light reddish brown 5YR 6/4  
to light brown 7.5YR 6/3, core: light red 10R 6/6,  
3.0×6.2×0.8(wall)-1.1(lip), D 18  
same type as POR04-4770-06-40 (with black gloss); strikingly dif-  
ferent red fabric colour; fresh breaks  
depurated clay  
Morel no. 4121 a 1? (p. 291; Pl. 117), date: mid 4<sup>th</sup> c. BC, prod.:  
Apulia

**BOWL/BASE [SEE PLATE VII]****BG27**

POR04-4770-02-05

flaring base ring, faceted edge, outside convex, inside concave  
ext. and int.: pale brown 10YR 6/3, core: light reddish brown 5YR  
6/4  
3.3×7.9×0.3(base)-0.6(wall), D 11  
striking brown fabric colour; worn  
depurated clay  
Morel P321a1 ? (p. 467; Pl. 235), date: end 4<sup>th</sup>-beg. 3<sup>rd</sup> c. BC

**BG28**

POR04-4770-01-08

flaring base ring, rounded edge, outside convex, inside concave  
ext. and int.: reddish yellow 5YR between 7/6 and 6/6, core: red  
2.5YR 6/6  
3.9×8.2×0.8(base)-0.7(wall), D 13  
some fresh breaks  
depurated clay  
Morel 1271 b 1? (p. 100; Pl. 10), date: c. 320-275 BC

**BG29**

POR04-4769-10-20

flaring base ring, rounded edge, outside convex, inside concave;  
exterior ring decorated with one horizontal groove  
ext. and int.: reddish yellow 5YR 7/6, core: red 2.5YR 6/8  
1.8×4.8×0.2(base)-0.3(wall), D c. 6.5  
same type as POR04-4769-03-04; slightly worn  
depurated clay  
Locri II no. 75 (p. 117; Tav. XXII), date: 360-350 BC (after Attic  
bowls with palmette stamps?) (see Morel 4100)

**BG30**

POR04-4769-04-13

flaring base ring, outside convex, inside concave; ring is not com-  
pletely preserved; exterior ring decorated with an encircling

horizontal ridge

ext.: reddish yellow 5YR 7/6, core: reddish yellow 5YR 6/6 and  
pinkish gray 7.5YR 6/2, gloss: black 5YR 2.5/1  
2.2×3.8×0.4(base)-0.3(wall), D 6  
could be Attic, because fragment has very depurated, smooth fa-  
bric with some very little glitters and orange/red changing to  
gray colour, which seems to be unique in this collection; fresh  
breaks  
depurated clay  
Morel no. 4221-4222 (p. 295-296; Pl. 120-121), date: around mid  
to end 4<sup>th</sup> c. BC, prod.: Attic with imitations in the West espe-  
cially in North-Apulia; also Mollo, 2003: No. C54? (p. 208;  
p. 427, Tav. LXI), date: 350/ 325-250 BC, found at Cetraro  
(CE06)

**BG31**

POR04-4770-07-26

flaring base ring, edge irregular, outside convex, inside concave;  
decorated with ridge on exterior of ring? (uncertain if ring base  
is broken or completely preserved)  
ext. and int.: reddish yellow 5YR between 7/6 and 6/6, core: red  
2.5YR 6/6, gloss: black 5YR 2.5/1  
1.3×3.6×0.3(base)-0.4(wall), D 5  
same type as POR04-4769-04-13?; fresh breaks  
depurated clay  
no parallel found yet

**CUP /RIM [SEE PLATES VII–VIII]****BG32**

POR04-4770-06-04

flaring wall, incurved rim, convex (almost flattened) lip which is  
thickened on the inside  
ext. and int.: reddish yellow 5YR 7/6, core: red 2.5YR 6/6, gloss:  
dark reddish brown 5YR 2.5/2  
1.6×4.7×0.5-0.8(wall)-0.9(lip), D 7.5  
slightly worn  
depurated clay  
Mollo, 2003: No. C83? (p. 215; p. 431, Tav. LXV), date: 350/ 325-  
250 BC, found at Cetraro (CE06) (see Morel 2710-2714)

**BG33**

POR04-4770-06-42

flaring wall, incurved rim, convex (almost flattened) lip which is  
thickened on the inside  
ext.: red 2.5YR 6/6, int.: reddish yellow 5YR 7/6, core: light red  
2.5YR 7/8, gloss: black 5YR 2.5/1 and weak red 2.5YR 5/4  
1.5×2.6×0.4(wall)-0.9(lip), D 8  
the gloss on this shard is changing from black to red, which is pro-  
bably caused during the firing process; fresh breaks  
depurated clay  
Mollo, 2003: No. C82? (p. 215; p. 431, Tav. LXV), date: 350/325-  
250 BC, found at Cetraro (CE06) (see Morel 2710-2714)



**BG34**

POR04-4770-06-41

flaring wall, incurved rim, convex (almost flattened) lip which is thickened on the inside

ext. and int.: reddish yellow 5YR 7/6, core: red 2.5YR 6/6, gloss: 5YR 2.5/1

1.6×3.5×0.7(wall)-0.8(lip), D 7.5

slightly worn

depurated clay

Mollo 2003 C81 (p. 215; p. 431, Tav. LXV), date: second half 4<sup>th</sup> - first half 3<sup>rd</sup> BC, found at Acquappesa (AC04) (see Morel 2710-2714); *Atti Lincei*, 1988/89: 206, No. 97 (St. 2106) (p. 221, fig.216)

**BG35**

POR05-4769-15-03

flaring wall with upright rim, convex (almost flattened) lip

ext. and int.: reddish yellow 5YR 7/6, core: reddish yellow 5YR 6/6, gloss: black 5YR 2.5/1

1.7×5.4×0.5(wall)-0.9(lip), D 8.5

black gloss preserved on all the surface, very thin horizontal incised line visible on the interior; fresh breaks

depurated clay

Mollo, 2003: No. C84? (p. 215; p. 431, Tav. LXV), date: 350/325-250 BC, found at Cetraro (CE06); *Atti Lincei*, 1988/89: 192, No.42 (St. 1613) (p. 212, fig. 212)

**BG36**

POR04-4769-12-26 &amp; 4769-09-33

flaring wall, convex lip which is thickened on the outside

ext. and int.: from light brown 7.5YR 6/4 to grayish brown 2.5Y 5/2, core: light reddish brown 5YR 6/4, gloss: black 5YR 2.5/1

1.5×8.0×0.4(wall)-1.0(lip), D 8

fresh breaks

depurated clay

Mollo, 2003: No. C86 (p. 215-216; p. 431, Tav. LXV), date: end 4<sup>th</sup>-beg. 3<sup>rd</sup> c. BC, found at Cetraro (CE16) (see Morel 2710-2714)

**BG37**

POR04-4769-12-10

slightly incurved rim, convex (almost flattened) lip which is thickened on the outside

ext. and int.: reddish yellow 5YR 6/6, core: red 2.5YR 6/6

1.8×2.3×0.3(wall)-0.8(lip), D c.13

worn

depurated clay

Mollo, 2003: No. C97(?) (p. 217; p. 432, Tav. LXVI), date: end 4<sup>th</sup>-beg. 3<sup>rd</sup> c. BC, found at Cetraro (CE16) (see Morel 2710-2714)

**BG38**

POR04-4769-04-07

slightly incurved rim, convex lip

ext., int. and core: from reddish yellow 5YR 7/6 to pinkish gray 5YR 6/2, gloss: black 5YR 2.5/1

1.3×2.3×0.5(wall)-0.6(lip), D c.11

fresh breaks

depurated clay

Mollo, 2003: No. C99 (p. 217; p.432, Tav. LXVI), date: 325-275 BC, found at Acquappesa (AC10)

**BG39**

POR04-4770-06-44

flaring wall, slightly incurved rim with convex lip

ext. and int.: from reddish yellow 5YR 6/6 to light brown 7.5YR 6/4, core: red 2.5YR 6/8, gloss: black 5YR 2.5/1

1.5×2.5×0.3(wall)-0.3(lip), D 12

fresh breaks

depurated clay

Mollo, 2003: C68? (p.211; p.429, Tav.LXIII), date: 350-250 BC, found at Acquappesa (AC04)

**BG40**

POR04-4770-02-02

slightly incurved rim, flattened lip which is thickened on the outside decorated with ridges

ext. and int.: reddish yellow 5YR between 7/6 and 7/8, core: red 2.5YR 6/6

2.1×4.7×0.8(wall)-0.9(lip), D 12

worn

depurated clay

no parallel found yet

**BG41**

POR04-4769-10-09

spreading wall, straight rim, flattened lip which is thickened on the outside (triangular in section) and slightly undercut

ext. and int.: reddish yellow 5YR between 7/6 and 6/6, core: red 2.5YR 6/6, gloss: red 10R 4/6

1.7×3.1×0.4(wall)-1.0(lip), D c.15

traces of black gloss which turn into a red colour; slightly worn depurated clay

Torre di Satriano no. 115 (p. 85; p. 84, fig. 56), date: second quarter 4<sup>th</sup> c. BC, cf.: Morel, 1981 (serie 1552): 123, Tav. 23

**CUP/BASE [SEE PLATE VIII]****BG42**

POR04-4769-11-66

flat base, inside concave

ext. and int.: reddish yellow 7.5YR 7/6, core: reddish yellow 5YR 7/6, gloss: black 5YR 2.5/1

0.8×3.3×0.3(base)-0.3(wall), D 4

the only parallel found has a much earlier dating; fresh breaks

depurated clay

(Locri II no. 8 (p. 76; Tav. XIX), date: end 6<sup>th</sup>-5<sup>th</sup> c.BC)

**BG43**

POR04-4769-09-41

flaring base ring (though very thin), rounded edge, outside concave, inside concave

ext. and int.: reddish yellow 5YR between 7/6 and 6/6, core: reddish yellow 5YR 6/8, gloss: black 5YR 2.5/1

1.6×4.9×0.5(base)-0.3(wall), D 7

fresh breaks

depurated clay

Mollo, 2003: No. C175? (p. 231; p. 443, Tav. LXXVII), date: end 4<sup>th</sup> - beg. 3<sup>rd</sup> c. BC, found at Cetraro (CE16)**BG44**

POR04-4770-01-07

flaring base ring (though very thin), rounded edge, outside convex, inside concave

ext. and int.: between red 2.5YR 6/6 and light red 2.5YR 7/6, core: red 2.5YR from 6/6 to 6/8

0.9×2.4×0.4(base)-0.6(wall), D c. 7

worn

depurated clay

Mollo, 2003: No. C82? (p. 215; p. 431, Tav. LXV), date: 350/325-250 BC, found at Cetraro (CE06); or Oppido Mamertina no. 452 (p. 277; p. 278 fig. 293), date: 275-150 BC, prod: Magna Grecia and Sicily (see Morel 2154)

**BG45**

POR04-4770-06-56

flaring base ring, rounded edge, inside concave, outside convex decorated with an encircling ridge

ext. and int.: between red 2.5YR 6/6 and light red 2.5YR 7/6, core: red 2.5YR 6/6, gloss: black 5YR 2.5/1

1.7×4.4×0.5(base)-0.7(wall), D 5

fresh breaks

depurated clay

Mollo, 2003: No. C79? (p. 214; p. 430, Tav. LXIV), date: 350/325-250 BC, found at Cetraro (CE06) (see Morel 2710-2714)

**BG46**

POR04-4769-09-39

flaring base ring, rounded edge, outside convex, inside concave, outside decorated with protruding centre point

ext. and int.: reddish yellow 5YR between 6/6 and 6/8, core: red 2.5YR 6/6, gloss: black 5YR 2.5/1 and from red 2.5YR 5/8 to dark red 2.5YR 4/6

1.3×4.4×0.6(base)-0.3(wall), D 4.2

same type as POR04-4770-07-25; worn

depurated clay

Morel no. 2714 c 1? (p. 209; Pl. 67), date: c. 310 BC, prod.: Magna Grecia and Sicily

**BG47**

POR04-4769-12-34

bottom of a (ring) base; inside is decorated with probably four palm leaves around a small circle in the centre, outside is decorated with three circles around the centre point

ext.: reddish yellow 5YR 7/6, core: red 2.5YR 6/6, gloss: black 5YR 2.5/1

4.7×3.6×0.8

fresh breaks

depurated clay

Locri II no. 197 (p. 190; Tav. XXVII), date: 380-360 BC

**SKYPHOS/RIM [SEE PLATE VIII]****BG48**

POR04-4769-09-35

slightly flaring wall, upright rim with convex lip; decorated with two incised horizontal lines in exterior

ext.: reddish brown 2.5YR 3/1, core: from red 2.5YR 6/8 to weak red 2.5YR 6.2, gloss: black 5YR 2.5/1

2.4×2.2×0.3(wall)-0.3(lip), D 10

gloss is in quite good condition and shiny, some fresh breaks

depurated clay

Roccagloriosa I no. 78 (p. 235, 237; p. 236, fig. 179), date: early 3<sup>rd</sup> c. BC, origin: Roccagloriosa**BG49**

POR04-4769-11-47

upright rim which is thickened on the inside, convex lip, attachment of handle

ext. and int.: reddish yellow 5YR 6/6, core: red 2.5YR 6/6, gloss: black 5YR 2.5/1

1.9×2.5×0.2(wall)-0.3(lip), D 9

fresh breaks

depurated clay

Yntema, 2001 K43b: No. 322 (p. 189; p. 186), date: late 4<sup>th</sup> - early 3<sup>rd</sup> c. BC, found at Valesio/ Apulia (Morel 4373)**BG50**

POR04-4769-11-46

outcurved rim with convex lip

ext. and int.: reddish yellow 5YR 7/6, core: red 2.5YR 6/8, gloss: (ext.) black 5YR 2.5/1, (int.) weak red 10R 5/4

2.4×3.1×0.3(wall)-0.4(lip), D 8

fresh breaks

depurated clay

Yntema, 2001 K43b: No. 324 (p. 189; p. 186), date: 3<sup>rd</sup> c. BC, found at Valesio/ Apulia (Morel 4373); Roccagloriosa I no. 74b? (p. 235; p. 236, fig. 179), date: early 4<sup>th</sup> c. BC**BG51**

POR04-4769-11-52

slightly outcurved rim, convex lip

core: weak red 2.5YR 6/4, gloss: black 5YR 2.5/1

1.4×1.6×0.3(wall)-0.4(lip), D 14

fresh breaks

depurated clay

Mollo, 2003: No. C32-33 (p. 204-205; p. 426, Tav. LX), date: end 4<sup>th</sup> - beg. 3<sup>rd</sup> c. BC, found at Acquappesa (AC01) (Morel 4370-4373); *Atti Lincei*, 1988/89: 222, No. 177 (St. 2966) (p. 227, fig. 218)

#### BG52

POR04-4769-11-49

slightly outcurved rim, convex lip

ext. and int.: reddish yellow 5YR 6/6, core: reddish yellow 5YR 6/6, gloss: black 5YR 2.5/1

2.2×2.3×0.3(wall)-0.3(wall), D 8

fresh breaks

depurated clay

Mollo, 2003: No. C42? (p. 206; p. 426, Tav. LX), date: 350-250 BC, found at Acquappesa (AC04) (no Morel); *Atti Lincei*, 1988/89: 222, No.178 (St. 2969) (p.227, fig.218)

#### BG53

POR04-4770-06-45

slightly outcurved rim with flattened lip, part of attachment of handle

ext. and int.: reddish yellow 5YR 6/6, core: reddish yellow 5YR 6/8, gloss: black 5YR 2.5/1

1.9×1.9×0.3(wall)-0.4(lip), D 10

worn

depurated clay

Roccagloriosa I no. 71 (p. 234-235; p. 236, fig. 179), date: first half of 4<sup>th</sup> c. BC or end of 5<sup>th</sup> c. BC

#### BG54

POR04-4769-09-07

slightly outcurved rim, flattened lip

ext. and int.: reddish yellow 5YR between 6/6 and 6/8, core: red 2.5YR 6/6

2.1×2.6×0.6(wall)-0.5(lip), D 10

worn

depurated clay but with some inclusions

Roccagloriosa I no. 71? (p. 234-235; p. 236, fig. 179), date: end 5<sup>th</sup>/ first half 4<sup>th</sup> c. BC

#### BG55

POR04-4769-03-03

slightly outcurved rim, convex lip which is thickened on the outside

ext. and int.: reddish yellow 5YR 7/6, core: red 2.5YR 6/6

0.9×1.7×0.2(wall)-0.6(lip), D 10

worn

depurated clay with some large inclusions

Torre di Satriano no. 163 (p. 93; p. 91, fig. 61), date: second half 4<sup>th</sup> - beg. 3<sup>rd</sup> c. BC (see Morel 4373)

#### SKYPHOS/HANDLE [SEE PLATE IX]

#### BG56

POR05-4769-13-11

slightly outcurved rim with convex lip, part of horizontal ring-handle, in section rounded

ext. and int.: reddish yellow 5YR 7/6, core: reddish yellow 5YR 6/6, gloss: black 5YR 2.5/1

3.1×1.0-1.1×1.0, 0.5(rim), D c.5

fresh breaks

depurated clay

Mollo, 2003: No. C30 (p. 204; p. 425, Tav. LIX), date: end 4<sup>th</sup> - beg. 3<sup>rd</sup> c. BC, found at Cetraro (CE16)

#### BG57

POR04-4770-05-26

slightly outcurved rim with convex lip thickened on the inside, part of horizontal ring-handle, in section rounded

ext. and int.: reddish yellow 5YR 7/6, core: reddish yellow 5YR between 7/6 and 6/6, gloss: black 5YR 2.5/1

2.6×1.0-0.8×0.6, 0.3(rim)×0.4(wall), D 6

fresh breaks

depurated clay

Roccagloriosa I no. 74b (p. 235; p. 236, fig. 179), date: 4<sup>th</sup> - 3<sup>rd</sup> c. BC

#### SKYPHOS/BASE [SEE PLATE IX]

#### BG58

POR04-4770-07-27

flaring base ring, rounded edge, outside convex, inside concave

ext.: reddish yellow 5YR between 7/6 and 6/6, int.: between red 2.5YR 6/6 and reddish yellow 5YR 6/6, core: red 2.5YR 6/6, gloss: varying from black 7.5YR 2.5/1 to very dark brown 7.5YR 2.5/3

1.3×2.9×0.3(base)-0.3(wall), D 5

fresh breaks

depurated clay

Morel no. 4311 a 1 (p. 305; Pl. 126), date: second half 4<sup>th</sup> c. BC, prod.: South-Italy and Sicily, origin: Attic

#### BG59

POR05-4769-13-14

flaring base ring, rounded edge, outside convex, inside concave

ext. and int.: reddish yellow 5YR 6/8, core: red 2.5YR 6/6, gloss: black 5YR 2.5/1 and red 2.5YR 5/8

1.8×5.3×0.8(base)-0.5(wall), D 5.5

traces of black and red gloss probably caused by firing; fresh breaks

depurated clay

Morel no. 4311 a 2 (p. 305; Pl. 126), date: 4<sup>th</sup> c. BC (mostly second half?), prod.: South-Italy and Sicily, origin: Attic

**BG60**

POR04-4769-11-57

flaring base ring, rounded edge, outside convex, inside concave  
ext. and int.: reddish yellow 5YR between 6/6 and 6/8 and light  
brown 7.5YR 6/4, core: red 2.5YR 6/8, gloss: black 5YR 2.5/1  
and dark red 2.5YR 4/6 and 4/8

1.7×5.0×0.5(base)-0.4(wall), D 6

traces of black and red gloss probably caused by firing; fresh  
breaks

depurated clay

Morel no. 4311 b 2 (p. 305; Pl. 126), date: end 4<sup>th</sup> c. BC, prod.:

South-Italy and Sicily, origin: Attic; *Atti Lincei*, 1988/89: 196,  
No. 60 (St. 1798) (p. 212, fig. 212)

**BG61**

POR04-4769-11-60

flaring base ring, rounded edge, outside convex, inside concave  
ext.: reddish yellow 5YR 7/6, int.: reddish yellow 5YR 6/6, core:  
red 2.5YR 6/6, gloss: black 5YR 2.5/1 and dark reddish brown  
5YR 2.5/2

1.3×2.7×0.3(base)-0.5(wall), D 6

fresh breaks

depurated clay

Morel no. 4311 b 2 (p. 305; Pl. 126), date: end 4<sup>th</sup> c. BC, prod.:

South-Italy and Sicily, origin: Attic

**BG62**

POR04-4769-11-53

flaring elongated base ring with rounded edge  
ext.: reddish yellow 7.5YR 7/6, core: light red 2.5YR 7/6, gloss:  
black 5YR 2.5/1

0.9×3.6×0.7(wall) - 0.4(base) - 0.6(foot), D 12

gloss is shiny; slightly worn

depurated clay

Morel 4311 c 1? (p. 305; Pl. 126), date: 335-300 BC, found at

Lipari

**BG63**

POR04-4769-04-12

flaring base ring, rounded edge, outside convex, inside concave  
ext. and int.: from reddish yellow 5YR 7/6 to pinkish gray 7.5YR  
6/2, core: weak red 2.5YR 6/4 and dark reddish gray

2.0×4.8×0.4(base)-0.4(wall), D 5

striking red fabric colour; fresh breaks

depurated clay

Roccagloriosa I no. 86 (p. 238; p. 236, fig. 179), date: mid to late

4<sup>th</sup> c. BC, or: Morel no. 4373 a 2 (p. 311; Pl. 131), date: 335-  
300 BC, prod.: Apulia

**BG64**

POR04-4769-11-59

flaring base ring, rounded edge, outside convex, inside concave  
ext.: reddish yellow 5YR between 7/6 and 6/6, core: red 2.5YR

6/6, gloss: black 5YR 2.5/1

2.6×3.7×0.3(base)-0.3(wall), D 5.5

fresh breaks

depurated clay

Roccagloriosa I no. 86 (p. 238; p. 236, fig. 179), date: mid to late

4<sup>th</sup> c. BC; Morel no. 4373 a 2 (p. 311; Pl. 131), date: 335-300

BC, prod.: Apulia; Torre di Satriano no. 168 (p. 95; p. 94, fig.

62), date: second half 4<sup>th</sup>-beg. 3<sup>rd</sup> c. BC; *Atti Lincei*, 1988/89:

535, No. 55 (CB 568) (p. 577, fig. 563)

**BG65**

POR04-4769-10-42

flaring base ring, rounded edge, outside convex, inside concave  
ext.: reddish yellow 5YR between 7/6 and 6/6, int.: reddish yellow  
5YR 6/6 and light reddish brown 6/4, core: red 2.5YR 6/6,  
gloss: black 5YR 2.5/1

2.3×3.6×0.3(base)-0.3(wall), D 5

some fresh breaks, inside of ring decorated with black gloss

depurated clay

Roccagloriosa I no. 86 (p. 238; p. 236, fig. 179), date: mid to late

4<sup>th</sup> c. BC; Morel no. 4373 a 2 (p. 311; Pl. 131), date: 335-300

BC, prod.: Apulia; Torre di Satriano no. 168 (p. 95; p. 94, fig.

62), date: second half 4<sup>th</sup>-beg. 3<sup>rd</sup> c. BC**BG66**

POR04-4769-04-11

flaring base ring, faceted edge, outside convex, inside concave  
ext.: reddish yellow 5YR between 7/6 and 6/6, int.: reddish yellow  
5YR 6/6, core: red 2.5YR 6/8, inner core: weak red 2.5YR 6/4,  
gloss: black 5YR 2.5/1

1.9×5.7×0.7(base)-0.7(wall), D 8

fresh breaks

depurated clay

Morel no. 4352 a 1 (p. 308; Pl. 129), date: c. 300 BC, prod.: cen-

tral Italy

**BG67**

POR04-4769-08-19

flaring base ring, faceted edge, outside convex, inside concave  
ext. and int.: reddish yellow 5YR from 6/6 to 7/8, core: light red  
2.5YR 7/8, gloss: black 5YR 2.5/1

2.1×4.9×0.5(base)-0.5(wall), D 6.5

slightly worn

depurated clay

Morel no. 4373 (c 1?) (p. 311; Pl. 131), date: end 4<sup>th</sup> c. BC (- beg.3<sup>rd</sup> c. BC), prod.: Apulia; *Atti Lincei*, 1988/89: 223, No. 185 (St.

2909) (p. 224, fig. 217)

**BG68**

POR04-4769-03-09

flaring base ring, faceted edge with horizontal small groove on  
exterior, outside convex, inside concave

ext. and int.: reddish yellow 5YR 6/6, core: red 2.5YR 6/6

1.4×6.5×0.7(base)-0.5(wall), D 6.5  
on exterior of bottom traces of probably wheel turning are visible;  
fresh breaks  
depurated clay  
Morel 4373 (a 1?) (p. 311; Pl. 131), date: end 4<sup>th</sup> c. BC, prod.:  
Apulia; *Atti Lincei*, 1988/89: 210, No. 120 (St. 2286) (p. 221,  
fig. 216)

**BG69**

POR04-4769-11-55  
flaring base ring, slightly faceted edge, outside convex, inside con-  
cave, exterior of bottom decorated with two black circles  
ext. and int.: reddish yellow 5YR 6/6, core: red 2.5YR 6/6, gloss:  
black 5YR 2.5/1  
1.8×5.2×0.6(base)-0.3(wall), D 5.2  
worn  
depurated clay  
Morel 4373 (b 2?) (p. 311; Pl. 131), date: end 4<sup>th</sup> c. BC, prod.:  
Apulia

**BG70**

POR05-4769-13-13  
flaring base ring, slightly faceted edge, outside convex, inside  
concave, traces of a circular decoration on exterior of bottom  
visible  
ext.: reddish yellow 5YR 7/6, int.: reddish yellow 5YR 6/6 and  
pinkish gray 5YR 6/2, core: light reddish brown 5YR  
2.1×5.3×0.6(base)-0.3(wall), D 5.3  
fabric is really hard and shiny; fresh breaks  
depurated clay  
Morel 4373 (b 1?) (p. 311; Pl. 131), date: end 4<sup>th</sup> c. BC, prod.:  
Apulia; *Atti Lincei*, 1988/89: 219, No. 164 (St. 2684) (p. 224,  
fig. 217)

**BG71**

POR04-4769-12-30  
flaring base ring, slightly faceted edge, outside convex, inside con-  
cave, exterior of bottom decorated with black circle  
ext.: reddish yellow 5YR between 7/6 and 6/6, int.: weak red  
2.5YR 6/4, core: red 2.5YR 6/6 and gray 5YR 6/1, gloss: from  
gray 5YR 6/1 to black 5YR  
3.2×3.2×0.5(base)-0.4(wall), D 9.5  
striking red fabric colour; fresh breaks  
depurated clay  
Rocagloriosa I no. 81b (p. 237; p. 236 fig. 179), date: end 5<sup>th</sup> - 4<sup>th</sup>  
c. BC, origin: Attic (see Morel 4382 a 1 (p. 313; Pl. 132), date:  
350-325 BC, prod.: Sicily and Campania, or Attic?)

**CRATER/RIM [SEE PLATE X]****BG72**

POR04-4771-01-14

outturned rim, elongated flat lip with profiled lip, exterior with a  
horizontal groove  
ext.: reddish yellow 5YR from 7/6 to 6/6, core: red 2.5YR 6/8, in-  
ner core: weak red 2.5YR 6/4, gloss: black 5YR 2.5/1 and dark  
reddish brown 5YR 2.5/2  
1.5×5.1×0.8 (wall) - 1.5(lip), D c. 40  
fresh breaks  
depurated clay  
Locri II no. 272 (p. 238; Tav. XXX), date: end 4<sup>th</sup>-beg. 3<sup>rd</sup> c. BC,  
origin: Apulia, in Attic tradition (see Morel 4614-4618); *Atti  
Lincei*, 1988/89: 449, No. 373 (PS 32066) (p. 473, fig. 475);  
*Atti Lincei*, 1988/89: 529, No.16 (CB 486) (p. 576, fig. 562)

**CRATER/HANDLE [SEE PLATE X]****BG73**

POR04-4770-04-14  
lug, in section rectangular with rounded edges  
ext.: between reddish yellow 5YR 7/6 and light reddish brown  
5YR 6/4, core: reddish yellow 5YR 7/6, gloss: black 5YR  
2.5/1  
3.9×3.7×1.6  
worn  
depurated clay  
Morel no. 4618 c 1 (p. 323; Pl. 140), date: c. end 4<sup>th</sup> c. BC, found  
at Valesio, prod.: Gnathia; (or: Morel no. 4731 b 2 (p. 328; Pl.  
144), date: end 4<sup>th</sup>-beg. 3<sup>rd</sup> c. BC, prod.: Gnathia)

**BG74**

POR04-4769-11-42  
flaring high base ring with outturned rounded edge  
ext., int. and core: very pale brown 10YR from 8/4 to 7/4 and light  
gray 10YR 7/2, gloss: from black 5YR 2.5/1 to dark reddish  
brown 2.5/2  
2.3×5.0×0.7(wall) - 1.2(foot), D 8  
striking light fabric colour; fresh breaks  
depurated clay  
Locri II no. 273 (p. 238; Tav. XXX), date: end 4<sup>th</sup>-beg. 3<sup>rd</sup> c. BC,  
origin: Apulia in Attic tradition (see Morel 4600)

**BG75**

POR04-4769-11-43  
flaring high base ring with profiled edge  
ext. and int.: reddish yellow 5YR 6/6, core: red 2.5YR 6/6, gloss:  
from black 5YR 2.5/1 to dark reddish brown 5YR 2.5/2  
4.0×4.2×1.2(wall) - 1.5(foot), D 13  
fresh breaks  
depurated clay  
Oppido Mamertina no. 492 ? (p. 283, fig. 295), date: first half 3<sup>rd</sup>  
c. BC (see Morel 4262); *Atti Lincei*, 1988/89: 529, No.17, (CB  
492) (p. 576, fig. 562)

**BLACK GLOSS/CLOSED FORMS****JUG/RIM [SEE PLATES X–XII]****BG76**

POR04-4769-10-08

straight rim, flattened lip with thickening on the outside  
ext. and int.: reddish yellow 5YR 6/6, core: red 2.5YR 6/6, gloss:  
5YR 2.5/1

2.4×3.3×0.4(wall)-0.8(lip), D c.17

fresh breaks

depurated clay

no parallel found yet

**BG77**

POR04-4769-11-25

straight rim, flattened lip which is thickened on the outside  
ext. and int.: reddish yellow 5YR 6/8, core: red 2.5YR 6/6  
2.3×5.7×0.3(wall)-0.8(lip), D 13

fresh breaks

depurated clay

no parallel found yet

**BG78**

POR05-4769-13-07

flaring wall, straight rim, flattened lip which is thickened on the  
outside, decorated with thin horizontal incised line on the ex-  
terior of the lip

ext. and int.: reddish yellow 5YR 7/6, core: red 2.5YR 6/8, inner  
core: red

2.5YR 6/6, gloss: black 5YR 2.5/1

2.2×5.9×0.3(wall)-0.7(lip), D 15

fresh breaks

depurated clay

no parallel found yet

**BG79**

POR05-4769-13-05

flaring wall, upright rim, flattened lip which is thickened on the  
outside

ext.: reddish yellow 7.5YR 7/6, int.: reddish yellow 5YR 7/6, core:  
red 2.5YR 6/6, gloss: black 5YR 2.5/1

4.2×5.3×0.4(wall)-0.7(lip), D 13

fresh breaks

depurated clay

Morel no. 5211 ? (p. 339; Pl.155) "Vases de la Daunie", date:

(333-300 BC and) 350-300 BC, found at Ordon, prod.: local  
or regional

**BG80**

POR04-4769-09-04

upright rim, flattened lip which is thickened on the outside  
ext. and int.: reddish yellow 5YR 7/6, core: reddish yellow 5YR

6/6

2.7×3.9×0.4(wall)-0.9(lip), D c.12

slightly worn

depurated clay

Morel no. 5211 ? (p. 339; Pl. 155) "Vases de la Daunie", date:

(333-300 BC and) 350-300 BC, found at Ordon, prod.: local  
or regional

**BG81**

POR04-4769-01-10

flaring wall, upright rim, flattened lip which is thickened on the  
outside

ext. and int.: reddish yellow 5YR 6/6, core: red 2.5YR 6/6

2.2×3.8×0.3(wall)-0.7(lip), D 12

fresh breaks

depurated clay

*Atti Lincei*, 1988/89: 458, No. 413 (PS 32269) (p. 511, fig. 504),date: 4<sup>th</sup>-3<sup>rd</sup> c. BC?**BG82**

POR04-4770-05-24

upright rim, flattened lip which is thickened on the outside

ext. and int.: reddish yellow 5YR 6/6, core: red 2.5YR 6/6, traces  
of gloss: red 10R 4/6

2.2×2.9×0.4(wall)-0.9(lip), D 12

no black gloss left; slightly worn

depurated clay

*Atti Lincei*, 1972: 208, No. 61 (CB 3504) (p. 250, fig. 256) date: ?,

local production with limited diffusion

**BG83**

POR04-4769-09-05

slightly incurving rim, flattened lip with thickening on the outside

ext. and int.: reddish yellow 5YR 7/6, core: reddish yellow 5YR  
6/6, gloss: black 5YR 2.5/1 and red 2.5YR 6/6

2.5×5.5×0.2(wall)-0.8(lip), D 12

fresh breaks

depurated clay

*Atti Lincei*, 1988/89: 475, No. 476 ? (PS 32678) (p. 515, fig. 507),date: ?, cf.: *Atti Lincei*, 1971: 207, No. 54.**BG84**

POR04-4769-01-11

flaring wall with upright rim, flattened lip which is thickened on  
the outside

ext. and int.: reddish yellow 7.5YR 6/6, core: red 2.5YR 6/8, inner  
core: red 2.5YR 6/6, gloss: black 5YR 2.5/1

1.8×2.8×0.3(wall)-0.7(lip), D c.15

fresh breaks

depurated clay

*Atti Lincei*, 1988/89: 320, No. 57 (PdC 5777) (p. 319, fig. 291),

date?

**BG85**

POR04-4769-11-45

almost upright rim, flattened lip which is thickened on the outside  
ext. and int.: reddish yellow 5YR between 6/6 and 7/6, core: red

2.5YR 6/6, gloss: light yellowish brown 10YR 6/4

2.3×3.9×0.4(wall)-0.7(lip), D 11

worn

depurated clay

no parallel found yet

**BG86**

POR04-4770-06-03

flaring wall with a straight rim, flattened lip which is thickened on  
the outside

ext. and int.: reddish yellow 5YR 7/6, core: red 2.5YR 6/6

2.3×3.6×0.5(wall)-0.7(lip), D c.14

fresh breaks

depurated clay

*Atti Lincei*, 1988/89: 543, No. 123 (CB 297) (p. 574, fig. 560),

date: 4<sup>th</sup>-3<sup>rd</sup> c. BC, cf.: *Atti Lincei*, 1971: 207-208, Nos 54, 61;

*Atti Lincei*, 1972: 491, No. 190; 491, No. 193; cf.: "supra", No.  
476 (PS 32678)

**BG87**

POR04-4769-11-44

straight rim, flattened lip which is thickened on the outside

ext. and int.: reddish yellow 5YR 6/6, core: red 2.5YR 6/6, gloss:

black 5YR 2.5/1

2.7×4.5×0.3(wall)-1.1(lip), D c.18

worn

depurated clay

*Atti Lincei*, 1988/89: 543, No. 126 (CB 917) (p. 579, fig. 565),

date: 4<sup>th</sup>-3<sup>rd</sup> c. BC, cf.: see No. 117: *Atti Lincei*, 1971: 207-208,  
Nos 54, 61; *Atti Lincei*, 1972: 491, No. 193, cf.: "supra", No.

476 (PS 32678)

**BG88**

POR04-4769-11-26

flaring wall with straight rim, flattened lip which is thickened on  
the outside

ext. and int.: reddish yellow 5YR 6/6, core: red 2.5YR 6/6

1.8×3.9×0.3(wall)-0.8(lip), D c.16

fresh breaks

depurated clay

no parallel found yet

**BG89**

POR04-4770-06-39

incurved rim, bevelled lip which is thickened on the outside; deco-  
rated with band of black gloss on interior right below the lip

ext. and int.: reddish yellow 5YR 6/6, core: reddish yellow 5YR

6/8, gloss: black 5YR 2.5/1

2.8×5.1×0.4(wall)-0.9(lip), D 16

slightly worn

depurated clay

S. Maria del Cedro: 458, No. 50 (p. 452, fig. 37), date: 4<sup>th</sup>-3<sup>rd</sup> c.BC  
("Anfora")

**BG90**

POR05-4769-13-06

flaring wall, very slightly incurved rim, flattened lip which is thic-  
kened on the outside, interior 'ridge' to put on a lid?

ext. and int.: reddish yellow 5YR between 7/6 and 6/6, core: red-  
dish yellow 5YR 6/6, gloss: between dark reddish

3.4×5.8×0.4(wall)-0.7(lip), D 15

seems to be decorated with black gloss only on upper part of rim  
as well as on the in- and the outside, fresh breaks

depurated clay

*Atti Lincei*, 1988/89: 278, No. 133 (Inc. 1496) (p. 280, fig. 255),

date: 4<sup>th</sup>-3<sup>rd</sup> c. BC, origin: local production?

**BG91**

POR04-4769-10-06

flaring wall, upright rim, flattened lip which is thickened on the  
outside, interior 'ridge' to put on a lid?

ext. and int.: reddish yellow 5YR 7/6, core: red 2.5YR 6/6, gloss:

red 10R 4/6

2.9×3.1×0.3(wall)-0.7(lip), D 17

no traces of black gloss left; slightly worn

depurated clay

no parallel found yet

**BG92**

POR04-4769-02-09

flaring wall with upright rim, flattened lip which is thickened on  
the outside, interior 'ridge' to put on a lid?

ext.: reddish yellow 5YR 6/6, int.: light brown 7.5YR 6/4, core:

gray 2.5YR 6/1

1.8×3.7×0.4(wall)-0.7(lip), D c.11

slightly worn

depurated clay

no parallel found yet

**BG93**

POR04-4769-10-07

flaring wall with almost upright rim, flattened lip

ext. and int.: light brown 7.5YR 6/4, core: weak red 2.5YR 6/4

1.9×3.0×0.3(wall)-0.6(lip), D c.12

fresh breaks

depurated clay

no parallel found yet

**BG94**

POR04-4770-04-09

slightly incurved rim, flattened lip which is thickened on the out-  
side

ext. and int.: reddish yellow 5YR 7/6, core: reddish yellow 5YR 6/6  
 2.4×3.7×0.3(wall)-0.7(lip), D c.12  
 fresh breaks  
 deperated clay  
 Torre di Satriano: 89, 92, No. 140-143 (p. 88, fig. 59), date: second  
 half 4<sup>th</sup>-beg. 3<sup>rd</sup> c. BC, found at Santuario Dea Lucana (see  
 Morel 2424)

**BG95**

POR04-4770-05-06 & 4769-04-03  
 flaring wall with slightly incurved rim, flattened lip which is thick-  
 ened on the outside  
 ext. and int.: reddish yellow 5YR between 7/6 and 6/6, core: red  
 2.5YR 6/6  
 2.4×7.6×0.5(wall)-1.0(lip), D 19  
 fresh breaks  
 deperated clay  
 no parallel found yet

**BG96**

POR04-4769-10-36  
 flaring wall, slightly incurved rim, flattened lip which is thickened  
 on the outside; attachment of vertical band-handle, in section  
 rectangular with rounded edges  
 ext. and int.: from reddish yellow 5YR 6/6 to light reddish brown  
 5YR 6/4, core: red 2.5YR 6/6, gloss: black 5YR  
 rim: 2.3×6.6×0.4(wall)-0.7(wall), D 14; handle: 3.4×0.7  
 fresh breaks  
 deperated clay  
 no parallel found yet

**BG97**

POR04-4769-09-06  
 flaring wall, slightly incurved rim, convex lip which is thickened  
 on the outside; vertical band-handle, in section oval  
 ext. and int.: reddish yellow 5YR from 6/6 to 6/8, core: red 2.5YR  
 6/6  
 rim: 1.9×5.9×0.3(wall)-1.0(lip), D c.16; handle: 4.0×1.1  
 same type as POR04-4769-08-06?; fresh breaks  
 deperated clay  
 no parallel found yet

**BG98**

POR04-4769-08-06  
 slightly outcurved rim, convex lip which is thickened on the out-  
 side; vertical band-handle, in section oval?  
 ext. and int.: reddish yellow 5YR between 6/6 and 6/8, core: red  
 2.5YR 6/6  
 rim: 2.0×3.3×??(wall)-0.9(lip), D c.12; handle: fragmentary  
 fresh breaks  
 deperated clay  
 Mollo, 2003: No. C128 (p. 223; p. 436, Tav.LXX), date: 350/325-  
 250 BC, found at Cetraro (CE06)

**BG99**

POR04-4769-12-09  
 flaring wall with slightly incurved rim, flattened lip which is thick-  
 ened on the outside  
 ext. and int.: reddish yellow 5YR between 6/6 and 7/6, core: red  
 2.5YR 6/8, inner core: weak red 2.5YR 6/4  
 1.7×3.0×0.3(wall)-0.7(lip), D c.14  
 fresh breaks  
 deperated clay  
 no parallel found yet

**BG100**

POR04-4770-05-08  
 outcurved rim, flattened lip which is thickened on the in- and  
 outside  
 ext. and int.: from reddish yellow 5YR 7/6 to light brown 7.5YR  
 6/4, core: weak red 2.5YR 6/4  
 2.3×4.1×0.2(wall)-0.7(lip), D 11  
 worn  
 deperated clay  
 Mollo, 2003: No. C131 (p. 224; p. 437, Tav. LXXI), date: 350/  
 325-250 BC, found at Cetraro (CE06) (see Morel 5620) or  
 Mollo, 2003: No. D2 (p. 237; p. 444, Tav. LXXVIII), date: end  
 4<sup>th</sup>-beg. 3<sup>rd</sup> c. BC, found at Acquappesa (also Sibari)

**BG101**

POR04-4769-11-67  
 upright rim with flattened lip, originally thickened on the inside?,  
 possible attachment of a ring-handle visible on the outside  
 ext. and int.: reddish yellow 5YR 7/6, core: light red 2.5YR 7/6,  
 gloss: black 5YR 2.5/1  
 2.0×3.5×0.6(wall) - 0.6(lip), D 6  
 fresh breaks  
 deperated clay  
 no parallel found yet

**JUG/HANDLE [SEE PLATE XII]****BG102**

POR04-4769-11-33  
 vertical band-handle, in section irregular with rounded edges, ex-  
 terior decorated with a ridge  
 ext.: reddish yellow 7.5YR 7/6, int.: reddish yellow 5YR 7/6, core:  
 reddish yellow 5YR 6/8  
 5.0×2.9×0.9  
 fresh breaks  
 deperated clay  
 Morel no. 5115 a 1 (?) (p. 335; Pl. 153), date: c. end 4<sup>th</sup> c. BC,  
 found at Rome

**BG103**

POR04-4769-04-04  
 vertical band-handle with rounded raised edges, in section oval



ext. and int.: between reddish yellow 7.5YR 7/6 and light brown 7.5YR 6/4, core: light reddish brown 5YR 6/4  
 3.6×2.2×0.7-0.9  
 worn  
 deperated clay  
 Morel 5113 e 1 (p. 335; Pl. 152) / 5213 c 1 (p. 340; Pl. 156), date: 4<sup>th</sup>-3<sup>rd</sup> c. BC, found at Volterra/ Campana with Etruscan production

**BG104**

POR04-4769-01-05  
 vertical band-handle, in section oval, with small part of neck/ rim  
 ext. and int.: between very pale brown 10YR 7/4 and yellow 10YR 7/6  
 2.7×3.7×1.3  
 slightly worn  
 deperated clay  
 no parallel found yet

**BG105**

POR04-4769-12-23  
 vertical band-handle, in section oval  
 ext. and int.: reddish yellow 5YR 6/8, core: red 2.5YR 6/6  
 5.7×3.5×1.2  
 slightly worn  
 deperated clay  
 no parallel found yet

**BG106**

POR04-4769-05-02  
 horizontal or vertical ring-handle, in section round  
 ext.: reddish yellow 5YR between 7/8 and 6/8, core: reddish yellow 5YR 6/6, traces of gloss: red 10R 4/6  
 6.5×1.3×1.3  
 no traces of black gloss left; fresh breaks  
 deperated clay  
 no parallel found yet

**JUG/BASE [SEE PLATES XII–XIII]****BG107**

POR04-4770-06-21  
 flaring base ring, rounded edge, outside convex, inside concave  
 ext. and int.: reddish yellow 5YR between 7/6 and 6/6, core: reddish yellow 5YR 6/6  
 1.1×4.5×0.3-0.5(base)-0.3(wall), D 6.5  
 interior bottom with protruding centre?; fresh breaks  
 deperated clay  
 no parallel found yet

**BG108**

POR04-4769-10-15  
 flaring base ring, rounded edge, outside concave, inside concave

ext. and int.: reddish yellow 5YR 7/6, core: pale red 2.5YR 7/4  
 2.4×5.6×0.4(base)-0.6(wall), D c.12  
 fresh breaks  
 deperated clay  
 Morel no. 5121 a 1? (p. 336; Pl. 154), date: mostly 3<sup>rd</sup> c. BC, prod.: Volterra (?)

**BG109**

POR04-4769-09-13  
 flaring base ring with rounded edge, outside convex, inside concave  
 ext.: reddish yellow 7.5YR 7/6, int.: reddish yellow 5YR 7/8, core: red 2.5YR 6/6  
 2.7×5.5×0.3(base)-0.4(wall), D 9  
 fresh breaks  
 deperated clay  
 Morel no. 5212 d 1? (p. 339; Pl. 155), date: 4<sup>th</sup>-3<sup>rd</sup> c. BC, prod.: Volterra (?)

**BG110**

POR04-4770-05-27  
 concave base, inside concave  
 ext.: varying from reddish yellow 7.5YR 7/6 to reddish yellow 5YR 6/6 to light reddish brown 5YR 6/4, int.: pink 5YR 7/4, core: red 2.5YR 6/6, gloss: black 5YR 2.5/1  
 2.8×5.2×0.5(base)-0.6(wall), D 4.5  
 fresh breaks  
 deperated clay  
*Atti Lincei*, 1988/89: 542, No. 112 (CB 855) (p. 579, fig. 565), date: end 4<sup>th</sup>-beg. 3<sup>rd</sup> c. BC, cf.: Sparkes-Talcott, "Agora" 12, p. 255, Tav. 13, 285 (for the *olpè* type), cf.: *Atti Lincei*, 1971: 214, Nos 98, 102; *Atti Lincei*, 1972: 520, No. 294.

**BG111**

POR04-4770-06-53  
 concave base, inside uncertain  
 ext. and int.: reddish yellow 5YR 7/6, core: reddish yellow 5YR 6/8, gloss: black 5YR 2.5/1 2.0×4.5×0.6(base)-0.6(wall), D c. 4.5  
 worn  
 deperated clay  
*Atti Lincei*, 1988/89: 542, No. 112 (CB 855) (p. 579, fig. 565), date: end 4<sup>th</sup>-beg. 3<sup>rd</sup> c. BC, cf.: Sparkes-Talcott, "Agora" 12, p. 255, Tav. 13, 285 (for the *olpè* type), cf.: *Atti Lincei*, 1971: 214, Nos 98, 102; *Atti Lincei*, 1972: 520, No. 294

**BG112**

POR04-4769-12-31  
 concave base, inside uncertain  
 ext.: reddish yellow 5YR 7/6 and light brown 7.5YR 6/4, int.: reddish yellow 7.5YR 6/6, core: reddish yellow 5YR 7/8, gloss: black 5YR 2.5/1  
 2.9×4.2×0.5(base)-0.4(wall), D 4.5

gloss shows brush strokes; fresh breaks  
depurated clay

*Atti Lincei*, 1988/89: 542, No. 113 (CB 856) (p. 579, fig. 565),  
date: end 4<sup>th</sup>-beg. 3<sup>rd</sup> c. BC, *cf.*: for the type of olpè see  
Sparkes-Talcott, "Agora" 12, p. 255, *cf.*: *Atti Lincei*, 1971:  
214, Nos 98, 102; *Atti Lincei*, 1972: 520, No. 294

**BG113**

POR04-4769-02-13

concave base, inside probably concave  
ext. and int.: reddish yellow 5YR between 7/6 and 6/6, core: red  
2.5YR 6/6, gloss: black 5YR 2.5/1  
4.0×3.8×0.8(base)-0.3(wall), D c.4.5  
fresh breaks  
depurated clay

*Atti Lincei*, 1988/89: 542, No. 113 (CB 856) (p. 579; fig. 565),  
date: end 4<sup>th</sup>-beg. 3<sup>rd</sup> c. BC, *cf.*: for the type of olpè see  
Sparkes-Talcott, "Agora" 12, p. 255, *cf.*: *Atti Lincei*, 1971:  
214, Nos 98, 102; *Atti Lincei*, 1972: 520, No. 294

**BG114**

POR04-4770-02-15

concave base, inside concave  
ext.: reddish yellow 5YR 7/6 and 7/8, int.: light reddish brown  
5YR 6/4, core: light red 2.5YR 7/8, gloss: black 5YR 2.5/1  
2.1×3.9×0.5(base)-0.5(wall), D 4.5  
fresh breaks  
depurated clay

*Atti Lincei*, 1988/89: 542, No. 113 ? (CB 856) (p. 579, fig. 565),  
or p. 565, No. 285 ? (CB 2439) (p. 587, fig. 573), date: end 4<sup>th</sup>-  
beg. 3<sup>rd</sup> *cf.*: p. 542, No. 112 (*Atti Lincei*, 1988/89), date: also  
end 4<sup>th</sup>-beg. 3<sup>rd</sup> c. BC

**BG115**

POR04-4770-07-24

concave base, inside concave  
ext.: reddish yellow 5YR from 7/6 to 6/6, int.: reddish yellow 5YR  
between 7/6 and 6/6, core: red 2.5YR 6/8, gloss: black 5YR  
2.5/1  
2.6×4.8×0.6(base)-0.5(wall), D 5.5  
gloss shows brush strokes; fresh breaks  
depurated clay

*Atti Lincei*, 1988/89: 318, No. 54 (PdC 4072) (p. 319, fig. 291),  
date: ?, *cf.*: *Atti Lincei*, 1970: 131, No. 123; *Atti Lincei*, 1971:  
214, No. 98, 102 ("Ceramica Italiota a V.N.")

**JUG/KNOB [SEE PLATE XIII]****BG116**

POR04-4769-07-04

circular knob with a rounded opening tapering downwards, part of  
wall preserved  
ext. and int.: reddish yellow 5YR 6/6, core: red 2.5YR 6/6, gloss:

red 10R 4/8 and some traces of black 5YR 2.5/1  
2.5×2.1-2.0(knob)×0.3-0.3(lid), D 2

slightly worn  
depurated clay

Mollo, 2003: No. C 143? (p. 226-227; p. 440, Tav. LXXIV), date:  
350/ 325 – 250 BC, found at Cetraro (CE06)

**LEKYTHOS/RIM [SEE PLATE XIII]****BG117**

POR04-4769-10-38

outcurved rim, convex lip, decorated with very profound (black)  
horizontal incised line on the exterior  
ext. and int.: reddish yellow 5YR 7/6, core: reddish yellow 5YR  
7/6, gloss: black 5YR 2.5/1

1.0×1.3×0.2(wall)-0.2(lip), D c. 3

fresh breaks

depurated clay

Mollo, 2003: No. A29 (p. 194; p. 419, Tav. LIII), date: 350/ 325-  
250 BC, found at Cetraro (CE06)

**BG118**

POR04-4769-11-50

outcurved rim, convex lip  
ext. and int.: reddish yellow 5YR 7/6, core: light red 2.5YR 7/6,  
gloss: black 5YR 2.5/1  
0.8×1.9×0.2(wall)-0.3(lip), D 5

worn

depurated clay

Mollo, 2003: No. A29 (p. 194; p. 419, Tav. LIII), date: 350/ 325-  
250 BC, found at Cetraro (CE06) (see Morel 5410)

**BG119**

POR04-4770-06-47

outcurved rim, flattened lip  
ext. and int.: reddish yellow 5YR 7/6, core: reddish yellow 5YR  
7/6

0.7×2.2×0.3(wall)-0.2(lip), D c. 6

worn

depurated clay

Mollo, 2003: No. A29 (p. 194; p. 419, Tav. LIII), date: 350/ 325-  
250 BC, found at Cetraro (CE06)

**BG120**

POR04-4769-11-27

outcurved rim, flattened lip which is thickened on the outside and  
with ridge on exterior  
ext. and int.: reddish yellow 5YR between 7/6 and 6/6, core: light  
red 2.5YR 7/6, traces of gloss: red 10R 4/6, (slip?: pink 5YR  
7/4)

1.9×2.5×0.4(wall)-0.9(lip), D 8

possibly some slip on the interior, no traces of black gloss; slightly  
worn

depurated clay  
Morel no. 5454? (p. 365; Pl. 172), date: first half 3<sup>rd</sup> c. BC?, found at Cagliari

**BG121**

POR04-4770-06-08

slightly outcurved rim, convex lip which is thickened on the outside

ext. and int.: reddish yellow 5YR 6/6, core: red 2.5YR 6/6, gloss: black 5YR 2.5/1

2.7×1.9×0.3(wall)-0.6(lip), D 3.5

worn

depurated clay

no parallel found yet

**BG122**

POR05-4769-13-16

shoulder with attachment of handle, decorated with lozenges and circle around handle attachment

ext. and int.: reddish yellow 7.5YR 7/6, core: reddish yellow 5YR 7/6, gloss: (around handle) black 5YR 2.5/1 and (lozenges) very dark brown 7.5YR 2.5/3

3.6×3.4×0.5(wall) - 1.0(attachment handle), D 3.5 (just above handle attachment)

very depurated fabric; gloss seems even more brown than black; fresh breaks

depurated clay

*Atti Lincei*, 1974: 82, No. 138 (St. 4590) (p. 46, fig. 32), *cf.*: St.72, 449; *Atti Lincei*, 1969: fig. 27, 50, date: end 4<sup>th</sup>-mid 3<sup>rd</sup> c. BC ("Ceramica Italiota a figure rosse"); *Atti Lincei*, 1988/89: 532, No. 32 (CB 492) (p. 532, fig. 523)

**LEKYTHOS/HANDLE [SEE PLATE XIII]****BG123**

POR04-4769-10-39

handle

ring-handle, in section round to oval with rounded edges

ext.: from reddish yellow 5YR 7/6 to very pale brown 10YR 7/3, core: from reddish yellow 5YR 7/6 to pale brown

5.2×1.1×0.7

slightly worn

depurated clay

no parallel found yet

**LEKYTHOS/BASE [SEE PLATE XIII]****BG124**

POR04-4769-11-37

flaring base ring, outside concave, inside concave

ext. and int.: weak red 2.5YR 6/4, core: red 2.5YR 6/6, inner core: weak red 2.5YR 6/2

1.6×6.0×0.6(base)-0.4(wall), D 5

striking red fabric colour as POR04-4770-06-40; fresh breaks

depurated clay

Mollo, 2003: No. C138? (p. 225; p. 438, Tav. LXXII), date: 350/325-250 BC, found at Cetraro (CE06) (see Morel 5416, date: 4<sup>th</sup> c. BC)

**BG125**

POR04-4770-06-54

flaring base ring, rounded edge, outside convex, inside concave

ext. and int.: reddish yellow 5YR 7/6, core: light red 2.5YR 7/6, gloss: black 5YR 2.5/1

1.0×3.6×0.3(base)-0.4(wall), D 4.5

fresh breaks

depurated clay

no parallel found yet

**BG126**

POR04-4770-06-55

flaring base ring with rounded edge, incurved wall

ext.: reddish yellow 7.5YR 7/5 and light red 2.5YR 7/6, int.: light red 2.5YR 7/6, core: light red 2.5YR 7/8, gloss: black 5YR 2.5/1

2.6×3.4×0.5(wall), D 3.5

worn

depurated clay

no parallel found yet

**LAMP FRAGMENT [SEE PLATE XIII]****BG127**

POR04-4769-09-44

spout of lamp with small part of body, rim of opening has a concentric deepening to receive a lid?, small part of a horizontal (ring?) handle is preserved on the side, decoration of an oval circle grooved at the right below the handle

ext. and int.: reddish yellow 7.5YR 7/6, core: reddish yellow 5YR 6/6, around the spout: gray 7.5YR from 5/1 to 6/1, gloss: black 7.5YR 2.5/1 and strong brown 7.5YR 5/6

5.3×4.3×3.0×1.8(spout)

fresh breaks

depurated clay

no parallel found yet

**CERAMICA COMUNE/DEPURATED CLAY****BASIN/RIM [SEE PLATE XIV]****CC1**

POR04-4770-06-02

outturned wall, straight rim, convex lip which is thickened on the in- and outside

ext. and int.: reddish yellow 5YR 6/6, core: red 2.5YR 6/6, traces

of gloss?: black 5YR 2.5/1 and very pale brown 10YR 7/4  
1.9×7.0×0.7(wall)-1.3(lip), D 30-33  
uncertain whether there is gloss on the shard; fresh breaks  
depurated clay  
Locri II no. 354/ 355 (p. 302-303; Tav. XL, XLIX), date: late 4<sup>th</sup>-  
3<sup>rd</sup> c. BC (“Ceramica comune da cucina e da dispensa”)

**CC2**

POR04-4769-12-08  
straight rim, convex lip which is thickened on the in- and outside  
ext. and int.: light brown 7.5YR 6/4, core: red 2.5YR 6/6  
1.7×4.5×0.6(wall)-1.3(lip), D c. 40  
traces of slip?; worn  
depurated clay  
Locri II no. 354/ 355 (p. 302-303; Tav. XL, XLIX), date: late 4<sup>th</sup>-  
3<sup>rd</sup> c. BC (“Ceramica comune da cucina e da dispensa”)

**CC3**

POR04-4769-12-07  
straight rim, convex lip which is thickened on the in- and outside  
ext. and int.: reddish yellow 5YR 6/6, core: red 2.5YR 6/6  
1.7×4.5×0.8(wall)-0.9(lip), D 37-38  
fresh breaks  
depurated clay  
Locri II no. 354/ 355 (p. 302-303; Tav. XL, XLIX), date: late 4<sup>th</sup>-  
3<sup>rd</sup> c. BC (“Ceramica comune da cucina e da dispensa”)

**CC4**

POR04-4769-09-31  
straight rim, convex lip which is thickened on the inside and with  
very pronounced thickening on the outside  
ext. and int.: reddish yellow 5YR 6/6, core: reddish yellow 5YR  
6/6, gloss: black 5YR 2.5/1  
1.8×7.4×0.7-0.8(wall)-1.7(lip), D 39  
traces of black gloss; fresh breaks  
depurated clay  
*Atti Lincei*, 1988/89: 548, No. 158 (CB 1090) (p. 580, fig. 566),  
date: 4<sup>th</sup>-beg. 3<sup>rd</sup> c. BC, cf.: *Atti Lincei*, 1971: 205, No. 43; *Atti*  
*Lincei*, 1972: 464, No. 58 (“Ceramica comune da cucina e da  
dispensa”) (like POR04-4769-12-08)

**CC5**

POR04-4770-05-29  
outturned wall, straight rim, convex lip which is thickened on the  
in- and outside; part of a horizontal ring-handle attached to rim  
and lip  
ext. and int.: reddish yellow 5YR 7/6, core: red 2.5YR 6/6, gloss:  
black 5YR 2.5/1  
2.3×6.0×0.7-0.8(wall) - 1.5(lip), D c. 38  
slightly worn  
depurated clay  
Locri II no. 354/355 (p. 302-303; Tav. XL, XLIX), date: late 4<sup>th</sup>-3<sup>rd</sup>  
c. BC (“Ceramica comune da cucina e da dispensa”)

**CC6**

POR05-4769-13-08  
outturned wall, straight rim, convex lip which is thickened on the  
in- and outside; part of horizontal ring-handle attached to rim  
and lip  
ext. and int.: reddish yellow 5YR 7/6, core: red 2.5YR 6/8  
1.8×6.8×1.0(wall) - 1.1(lip), D c. 40  
hard fired fabric with very small inclusions, same type as POR04-  
4770-05-29 but different fabric; fresh breaks  
depurated clay  
Locri II no. 354/ 355 (p. 302-303; Tav. XL, XLIX), date: late 4<sup>th</sup>-  
3<sup>rd</sup> c. BC (“Ceramica comune da cucina e da dispensa”); *Atti*  
*Lincei*, 1988/89: 220, No. 174 (St. 2875) (p. 227 fig. 218),  
date: 325-300 BC (although handle is attached differently)

**MORTAR/RIM [SEE PLATES XIV–XV]****CC7**

POR04-4769-12-06  
flaring wall, outturned rim, convex lip which is thickened on the  
outside  
ext. and int.: reddish yellow 5YR 6/6, core: red 2.5YR 6/6  
2.5×5.5×0.5(wall)-2.3(lip), D c. 40?  
fresh breaks  
depurated clay  
Locri II no. 349 (p. 297; Tav. XXXIX), date: late 4<sup>th</sup>-3<sup>rd</sup> c. BC  
 (“Ceramica comune da cucina e dispensa”); *Atti Lincei*,  
1988/89: 452, No. 390 (PS 32068) (p. 518, fig. 511), cf.: NSc,  
1960: 197, No. 8, found at Gela, date: 339-282 BC; *Atti Lincei*,  
1988/89: 566, No. 287 (CB 2458) (p. 587, fig. 573)

**CC8**

POR04-4769-10-05  
flaring wall, outturned rim, convex lip which is thickened on the  
outside  
ext. and int.: reddish yellow 5YR 6/6, core: red 2.5YR 6/8  
1.8×6.7×0.5(wall)-2.0(lip), D 24  
fresh breaks  
depurated clay  
Locri II no. 349 (p. 297; Tav. XXXIX), date: late 4<sup>th</sup>-3<sup>rd</sup> c. BC  
 (“Ceramica comune da cucina e da dispensa”); *Atti Lincei*,  
1988/89: 452, No. 390 (PS 32068) (p. 518, fig. 511), cf.: NSc,  
1960: 197, No. 8, found at Gela, date: 339-282 BC; *Atti Lincei*,  
1988/89: 546, No. 142 (CB 1024) (p. 579, fig. 565)

**CC9**

POR04-4769-10-04  
spreading wall, outturned rim, convex lip which is thickened on  
the outside and curling inwards  
ext. and int.: pale brown 10YR 6/3, core: reddish yellow 5YR 6/6  
1.9×6.9×0.5(wall)-2.1(lip), D 34-35  
second burn on exterior?; fresh breaks  
depurated clay

Locri II no. 349 (p. 297; Tav. XXXIX), date: late 4<sup>th</sup>-3<sup>rd</sup> c. BC  
 (“Ceramica comune da cucina e da dispensa”)

**BASIN “PELVIS”/RIM [SEE PLATE XVI]**

**CC10**

POR05-4769-13-02

incurved rim, convex lip which is thickened on the outside, exterior decorated with groove

ext. and int.: pale yellow 2.5Y 8/3, core: very pale brown 10YR 8/4

4.3×6.0×1.0(wall) - 4.0(lip), D 45-50

same type as POR05-4769-13-01; light fabric colour; fresh breaks  
 deperated clay

*Atti Lincei*, 1988/89: 562, No. 259 (CB 1999) (p. 585, fig. 571),  
 date: 4<sup>th</sup> c. BC, cf.: *Atti Lincei*, 1972: 456, No. 16; 508, No. 249; 513, No. 272, *Atti Lincei*, 1971: 365, No. 209, (“Ceramica comune”) (the confronti from Sibari have parallels in Magna Grecia datable in the 4<sup>th</sup> c. BC)

**CC11**

POR05-4769-13-01

in curving rim, convex lip with thickening on the outside, exterior decorated with groove

ext. and int.: pale yellow 2.5Y 8/2, core: very pale brown 10YR 7/4

4.3×10.0×1.7(wall) - 4.3(lip), D c. 60 (?)

same type as POR05-4769-13-02; light fabric colour; fresh breaks  
 deperated clay

*Atti Lincei*, 1988/89: 562, No. 258 (CB 2000) (p. 585, fig. 571),  
 date: 4<sup>th</sup> c. BC, cf.: *Atti Lincei*, 1972: 456, No. 16; 508, No. 249; 513, No. 272. *Atti Lincei*, 1971: 365, No. 209; 197, No. 5  
 (“Ceramica comune”) (the confronti from Sibari have parallels in Magna Grecia datable in the 4<sup>th</sup> c. BC)

**COOKING POT/RIM [SEE PLATE XV]**

**CC12**

POR04-4770-06-06

outturned rim, flattened lip which is thickened on the outside, rim made to receive to lid

ext. and int.: reddish yellow 5YR 7/6, core: red 2.5YR 6/6

1.8×4.2×0.3(wall)-0.8(lip), D 26?

worn

deperated clay

no parallel found yet

**CC13**

POR04-4770-06-43

straight rim, flattened lip

ext. and int.: reddish yellow 5YR between 7/6 and 6/6, core: red 2.5YR 6/6, gloss: black 5YR 2.5/1

1.9×4.4×0.9(lip), D 14

shallow cooking pot (tegame), or maybe jug (brocca)?; fresh breaks

deperated clay

tegame: *Atti Lincei*, 1988/89: 223, No. 187? (St. 2933) (p. 224, fig. 217), date: 325-300 BC

**STORAGE VESSEL/RIM [SEE PLATE XVI]**

**CC14**

POR04-4769-05-01

straight rim, lip irregularly flattened and thickened on the outside

ext. and int.: very pale brown 10YR 8/4, core: pink 7.5YR 8/4

6.7×10.8×1.9(wall) - 5.0(lip), D (>)60

light fabric colour; worn

deperated clay

no parallel found yet

**STORAGE VESSEL/BASE [SEE PLATE XV]**

**CC15**

POR04-4769-06-06

circular base with concave opening in the centre

ext. and int.: reddish yellow 5YRn7/6, core: reddish yellow 5YR 6/6, inner core?: light brown 7.5YR 6/4

3.7×7.2×3.8, D 7.5

fresh breaks

deperated clay

*Atti Lincei*, 1988/89: 554, No. 201? (CB 1623) (p. 583, fig. 569) (“Anfora”)

**COARSE WARE CLAY**

**MISCELLANEOUS/RIM [SEE PLATE XVII]**

**CC16**

POR04-4770-04-06

upright rim, flattened lip which is thickened on the outside; horizontal ring-handle, in section round

ext. and int.: reddish yellow 5YR 6/6, core: red 2.5YR 5/6

rim: 1.5×2.2×0.3(wall)-0.7(lip), D 7; handle: D 0.9

slightly worn

coarse ware clay

no parallel found yet

**MISCELLANEOUS/HANDLE [SEE PLATE XVII]**

**CC17**

POR04-4769-08-11

fragment of horizontal ring-handle in section round, with part of wall

ext.: varying from reddish yellow 5YR 6/8 to 6/6 to light reddish brown 5YR 6/4, int.: red 2.5YR 6/8, core: red 2.5YR 6/6

wall: 3.0×2.2×0.3, handle: 2.5×1.2  
 same type as POR04-4770-05-12; slightly worn  
 coarse ware clay  
 no parallel found yet

**MISCELLANEOUS/LID [SEE PLATE XVII]**

**CC18**

POR05-4770-08-03  
 convex lid with rounded edge and cylindrical knob with flattened top  
 ext. and int.: reddish yellow 5YR 6/8, core: red 2.5YR 6/6  
 1.6×2.8×0.4(wall), D 1.6(knob) - 3.2(lid)  
 fresh breaks  
 coarse ware clay  
 no parallel found yet

**MISCELLANEOUS/RIM [SEE PLATE XVII]**

**CC19**

POR05-4770-08-02  
 slightly outcurved rim, convex lip angular thickened on the outside  
 ext. and int.: reddish yellow 5YR 6/8, core: weak red 2.5YR 6/4  
 4.9×5.3×0.8(wall) - 1.4(lip), D c. 9  
 slightly worn  
 coarse ware clay  
 no parallel found yet

**CC20**

POR04-4770-06-01  
 upright rim, flattened lip which is thickened on the outside and decorated with two grooves  
 ext.: from reddish yellow 5YR 6/6 to light reddish brown 5YR 6/4,  
 int.: reddish yellow 5YR 6/6, core: red 2.5YR  
 1.7×3.1×0.4(wall) - 0.7(lip), D 20 ?  
 slightly worn  
 coarse ware clay  
*Atti Lincei*, 1988/89: 556, No. 212-213 ? ("piccola anfora")  
 (CB1470-1471) (p. 581, fig. 567), date: 4<sup>th</sup>-3<sup>rd</sup> c. BC (D 12.4)

**CC21**

POR05-4769-13-03  
 outcurved rim, convex lip, flattened on top and on the outside, in section almond shaped  
 ext.: from reddish yellow 5YR 7/8 to light brown 7.5YR 6/4, core: pale brown 10YR 6/3  
 2.7×4.2×0.5(wall) - 0.7(lip), D 20  
 Slightly worn  
 coarse ware clay  
 Mollo D93 (p. 254; p. 459, Tav. XCIII), date: end 4<sup>th</sup>-beg. 3<sup>rd</sup> c. BC, found at Cetraro (CE16)

**MISCELLANEOUS/HANDLE [SEE PLATES XVII–XVIII]**

**CC22**

POR04-4769-12-12  
 (probably vertical) ring-handle, in section round  
 ext.: red 2.5YR 6/8, core: red 2.5YR 5/8  
 5.0×1.3  
 same type as POR04-4769-09-09 and POR04-4769-05-05; fresh breaks  
 coarse ware clay  
 no parallel

**CC23**

POR04-4769-06-02  
 (probably) vertical ring-handle, with part of attachment, in section from oval to round  
 ext.: red 2.5YR 6/6, core: red 2.5YR 6/8, inner core: very dark gray 7.5YR 3/1, slip on exterior?: very pale brown 10YR 4.6×3.9(attachment) - 2.6(handle)×1.3(attachment) - 1.7(handle)  
 very coarse clay; slightly worn  
 coarse ware clay  
 no parallel

**CC24**

POR04-4769-01-09  
 (probably vertical) ribbed ring-handle, in section irregularly rounded, decorated with a groove on the exterior  
 ext.: varying from grayish brown 10YR 5/2 to reddish yellow 5YR 6/6, core: red 2.5YR 5/8  
 5.0×1.2×1.1  
 fresh breaks  
 coarse ware clay  
 no parallel

**CC25**

POR04-4771-01-03  
 probably (vertical) double bar-handle, in section irregularly rounded  
 exterior: reddish yellow 5YR 6/8, core: red 2.5YR 6/6  
 3.0×1.2×0.8  
 slightly worn  
 coarse ware clay  
 no parallel

**CC26**

POR04-4770-04-05  
 vertical band-handle, in section oval  
 ext.: reddish yellow 5YR 6/6 (slip on ext.: black 2.5Y 2.5/1), core: red 2.5YR between 6/8 and 5/8  
 4.0×3.4×1.1  
 same type as POR04-4771-01-05 and POR04-4769-11-06; slightly worn  
 coarse ware clay  
 no parallel

**CC27**

POR04-4769-09-10

vertical band-handle, in section irregularly oval  
 ext.: reddish yellow 5YR 7/8, core: red 2.5YR 6/8  
 2.9×2.7×1.1  
 fresh breaks  
 coarse ware clay  
 no parallel

**CC28**

POR04-4769-10-13

vertical band-handle, in section irregularly oval, exterior decorated  
 with three ridges  
 ext.: between light red 2.5YR 7/8 and red 2.5YR 6/8, core: red  
 2.5YR 6/6  
 2.7×2.4×0.8  
 same type as POR04-4770-06-14; fresh breaks  
 coarse ware clay  
 no parallel

**CC29**

POR04-4770-06-10

vertical band-handle, in section irregularly oval, decorated with  
 three ridges  
 ext.: red 2.5YR between 6/8 and 5/8, core: red 2.5YR 5/8  
 3.0×1.9×0.8  
 fresh breaks  
 coarse ware clay  
 no parallel

**CC30**

POR04-4770-01-04

vertical band-handle, in section oval, decorated with central rec-  
 tangular ridge  
 ext.: grayish brown 10YR 5/2, core: red 2.5YR 6/8  
 2.1×1.8×1.2  
 very coarse surface; slightly worn  
 coarse ware clay  
 no parallel

**MISCELLANEOUS/BASE [SEE PLATE XVIII]****CC31**

POR04-4770-01-06

concave base, inside concave, exterior base with small ridge  
 ext. and int.: reddish yellow 5YR between 6/6 and 6/8, core: gray-  
 ish brown 2.5Y 5/2  
 1.0×0.2(base) - 0.3(wall), D 5.5  
 slightly worn  
 coarse ware clay  
 no parallel found yet

**COOKING POT/CHYTRAI/RIM [SEE PLATE XVIII]****CC327**

POR04-4769-12-04

upright wall and rim, convex lip which is thickened on the outside  
 ext.: brown 7.5YR 5/4, int.: red 2.5YR 5/6, core: weak red 2.5YR  
 5/4  
 2.4×3.7×0.3(wall) - 1.1(lip), D 8  
 fresh breaks  
 coarse ware clay  
 Roccagloriosa I no. 249 (p. 267, p. 266, fig. 186), date: from c.  
 500 BC onwards

**CC33**

POR04-4769-10-37

outcurved rim, convex lip which is thickened on the outside  
 ext.: reddish yellow 5YR 6/8, int.: red 2.5YR 5/6, core: red 2.5YR  
 6/6, (slip on ext.: black 5YR 2.5/1 and very pale brown 10YR  
 7/3  
 1.3×2.7×0.3(wall) - 0.9(lip), D c. 15  
 slip on the outside; slightly worn  
 coarse ware clay  
 no parallel found yet

**COOKING POT/PENTOLA/RIM [SEE PLATE XVIII]****CC34**

POR04-4769-12-02

slightly outcurved rim, convex lip which is thickened on the out-  
 side  
 ext.: reddish yellow 5YR 6/6, int.: from red 10R 5/6 to dark red-  
 dish gray 10R 4/1, core: red 2.5YR 6/8  
 2.9×3.5×0.5(wall) - 1.1(lip), D 10  
 slightly worn  
 coarse ware clay  
 Locri II no. 298 ? (p. 265; Tav. XXXVI), date: from end 5<sup>th</sup> until  
 entire 3<sup>rd</sup> c. BC, origin: Attic?

**CC35**

POR04-4769-09-03

straight rim, convex lip which is thickened on the outside  
 ext.: varying from red 10R 5/8 to dusky red 10R 3/4, int.: red  
 2.5YR 6/8, core: red 2.5YR 6/6  
 2.2×4.3×0.6(wall) - 1.3(lip), D 20  
 same type as POR04-4769-12-03; fresh breaks  
 coarse ware clay  
 no parallel found yet

**CC36**

POR04-4769-02-02

very slightly outcurved rim, flattened lip with very small thic-  
 kening on the outside  
 ext. and int.: reddish yellow 5YR between 7/8 and 6/8, core: red

2.5YR 6/6

3.8×5.6×1.4(wall) - 1.5(lip), D ?  
inclination uncertain; slightly worn  
coarse ware clay  
no parallel found yet

**COOKING POT/CASSEROLE/RIM [SEE PLATE XVIII]**

**CC37**

POR04-4769-09-08  
outcurved rim, flattened lip which is thickened on the inside, and  
ridge on the interior to receive a lid  
ext.: yellowish red 5YR 5/6 (slip on ext.: black 5YR 2.5/1 and int.:  
very pale brown 10YR 7/3), int.: red 2.5YR  
4.0×5.7×0.3(wall) - 0.8(lip), D c. 28  
slip on exterior and interior; fresh breaks  
coarse ware clay  
Locri II no. 316 (p. 277; Tav. XXXVII), date: 4<sup>th</sup>-3<sup>rd</sup> c. BC; *Atti  
Lincei*, 1988/89: 205, No. 88 (St. 2001) (p. 218, fig. 215)

**CC38**

POR04-4771-01-04  
upright rim, bevelled lip which is thickened on the inside  
ext.: between reddish yellow 5YR 6/6 and light reddish brown  
5YR 6/4, int.: between gray 10YR 6/1 and light brownish gray  
10YR 6/2, core: gray 10YR 6/1  
1.7×2.7×0.3(wall) - 1.1(lip), D 20-25  
slightly worn  
coarse ware clay  
no parallel

**COOKING POT/CASSEROLE/BASE [SEE PLATE XIX]**

**CC39**

POR04-4770-01-05  
slightly concave base, inside concave  
ext.: red 2.5YR 6/6 and 6/8, int.: reddish yellow 5YR 7/8 and light  
reddish brown 5YR 6/4, core: gray 2.5Y 5/1  
3.2×6.6×0.7(base) - 0.7(wall), D 10  
slightly worn  
coarse ware clay  
no parallel found yet

**STORAGE VESSEL/RIM [SEE PLATE XIX]**

**CC40**

POR05-4769-14-01  
upright rim, flattened lip which is thickened on the outside  
ext. and int.: reddish yellow 5YR 6/8, core: red 2.5YR 6/6  
6.5×21.2×2.0(wall) - 8.6(lip), D >60  
sandy fabric; slightly worn  
coarse ware clay  
no parallel found yet

**STORAGE VESSEL/HANDLE [SEE PLATE XIX]**

**CC41**

POR04-4769-12-19  
vertical ring-handle, in section round, with small part of wall  
ext. and int.: reddish yellow 5YR between 6/6 and 7/6, core: red  
2.5YR 6/6  
5.5×4.1×3.4  
fresh breaks  
coarse ware clay  
no parallel found yet

**BUILDING MATERIAL**

**TILE/RIM [SEE PLATE XX]**

**BM1**

POR04-4769-01-01  
rectangular profile, internal angle rounded, external angle flattened  
to bevelled  
ext.: reddish yellow 5YR 7/6, core: reddish yellow 5YR 6/8, inner  
core: red 2.5YR 5/6  
15.3×9.4×3.0×5.5  
many small sandy inclusions, the exterior clay colour is either  
quite orange as this fragment or quite red (secondary burn on  
exterior?); light orange slip?; fresh breaks  
coarse ware clay  
no parallel

**BM2**

POR04-4769-11-03  
rectangular profile, internal angle rounded, external angle flattened  
ext.: reddish yellow 5YR 6/6, core: red 2.5YR 6/6  
14.1×10.3×2.1×4.3  
like POR04-4769-01-01 the exterior clay colour is orange or red-  
dish; looks much the same as POR04-4769-01-01, but is smal-  
ler; fresh breaks  
coarse ware clay  
no parallel

**BM3**

POR04-4770-05-01  
rectangular to triangular profile, internal angle rounded, external  
angle flattened  
ext.: reddish yellow 5YR between 7/6 and 6/8, core: light red  
2.5YR 7/6  
15.5×6.6×2.0×4.6  
this type has a very orange fabric colour, and is smaller than  
POR04-4769-01-01; slip?; fresh breaks  
coarse ware clay  
no parallel



**BM4**

POR04-4769-11-01

Irregular, rectangular to triangular profile, internal angle is grooved, external angle is flattened

ext.: very pale brown 10YR from 8/3 to 8/4, core: reddish yellow 7.5YR 7/6

8.5×8.3×1.7×4.9

pale slip on upper side; the fabric is less sandy than POR04-4769-01-01, POR04-4769-11-03 and POR04-4770-05-01; unique fragment; fresh breaks

coarse ware clay

no parallel

**BM5**

POR04-4769-10-01

rectangular profile, internal angle rounded, external angle flattened to bevelled

ext.: very pale brown 10YR 8/3 (upper side), brownish yellow 10YR 6/6 (slip on upper side) and pink 7.5YR 8/4

15.8×7.8×2.3×4.9

pale brown slip on upper side; this fabric is less sandy than POR04-4769-01-01, POR04-4769-11-03 and POR04-4770-05-01; unique fragment; fresh breaks

coarse ware clay

no parallel

**BM6**

POR04-4769-08-03

triangular profile, internal angle slightly hollowed out, external angle flattened

ext.: reddish yellow 5YR 7/6, core: red 2.5YR 6/6

8.5×11.5×2.5×4.5

more inclusions than POR04-4769-11-01 and POR04-4769-10-01, but not as sandy as POR04-4769-01-01, POR04-4769-11-03 and POR04-4770-05-01; fresh breaks

coarse ware clay

no parallel

**BM7**

POR04-4769-12-01

triangular profile, internal angle continuous, external angle flattened

ext.: very pale brown 10YR 8/4, core: reddish yellow 7.5YR 7/6

14.1×7.5×2.1×4.6

many inclusions, but not sandy; unique fragment of this type; fresh breaks

coarse ware clay

no parallel

**BM8**

POR04-4770-03-02

interior rectangular profile, flattened angles

ext.: reddish yellow 5YR 7/6, core: red 2.5YR 6/8

12.8×13.4×3.0×3.1

sandy fabric and same colour as POR04-4769-01-01 and POR04-4769-11-03; fresh breaks

coarse ware clay

no parallel

**IMBRES [SEE PLATE XX]****BM9**

POR04-4770-02-01

triangular profile, internally continuous

ext.: reddish yellow 5YR between 6/6 and 6/8, core: red 2.5YR 6/8 9.6×10.3×2.4×3.0

sandy fabric and same reddish colour as POR04-4769-01-01 and POR04-4769-11-03; fresh breaks

coarse ware clay

no parallel

AMPHORAE

Rim fragments

Type 1: slightly outcurved

Plate I

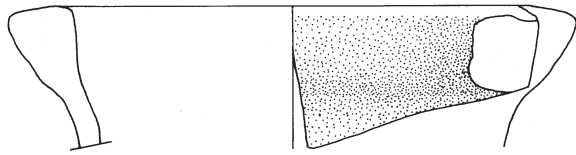

AM1

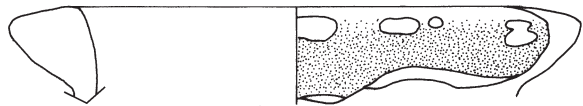

AM2

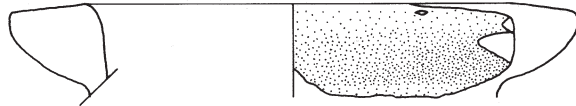

AM3

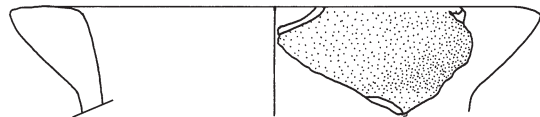

AM4

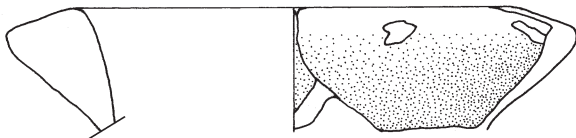

AM5

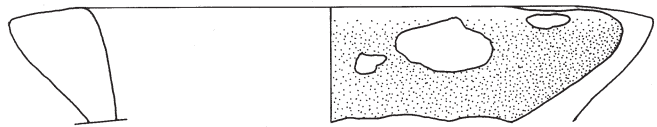

AM6

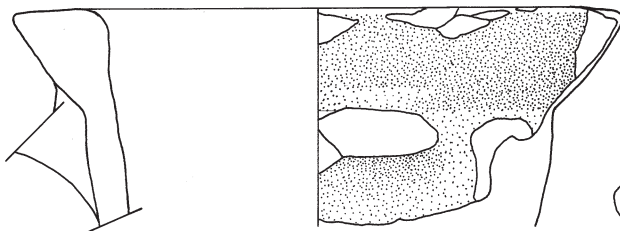

AM7

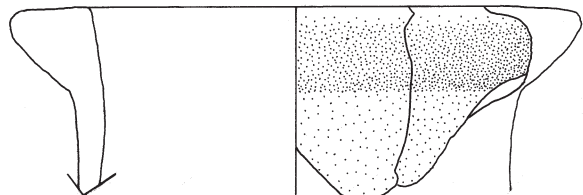

AM8

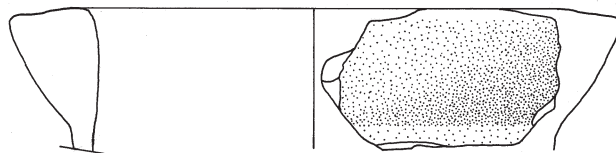

AM9

Type 2: outcurved

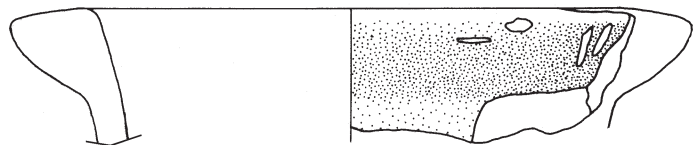

AM10

Plate II

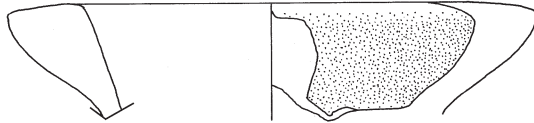

AM11



AM12

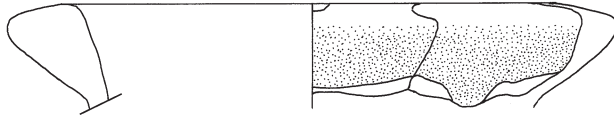

AM13

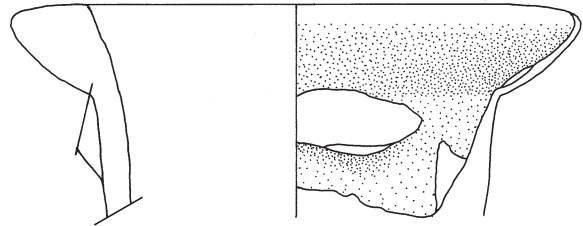

AM14

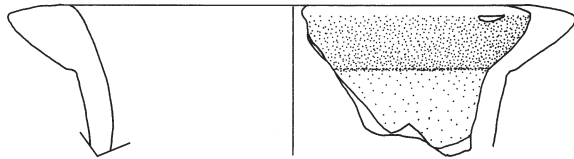

AM15

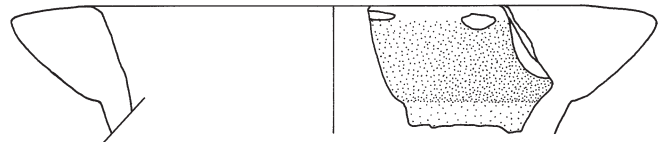

AM16

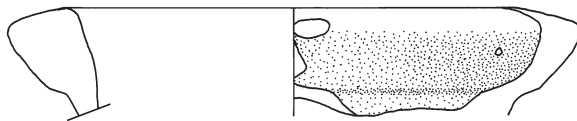

AM17

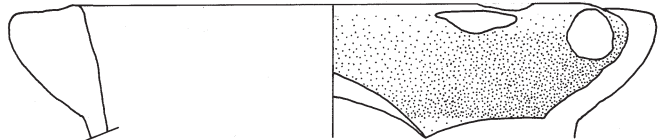

AM18

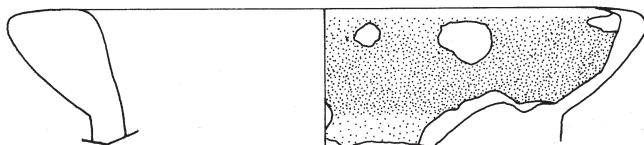

AM19

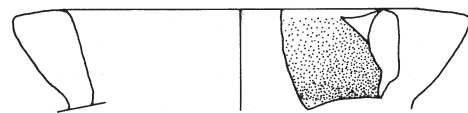

AM20

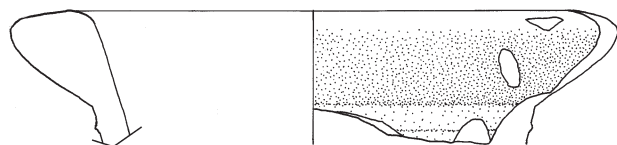

AM21

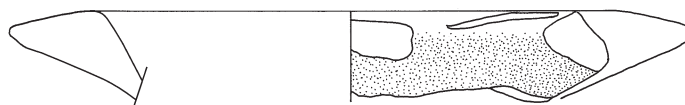

AM22

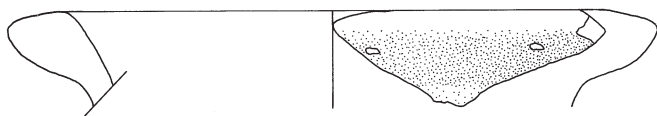

AM23

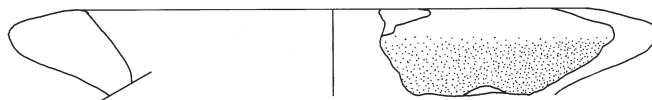

AM24

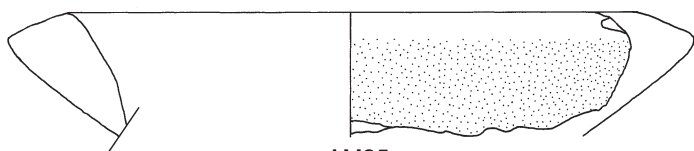

AM25

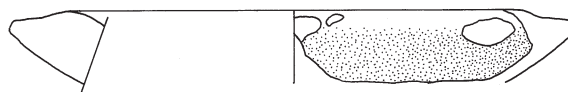

AM26

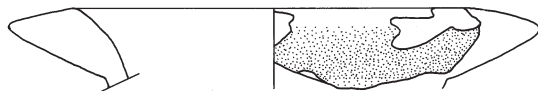

AM27

---

Subtype of type 2: decorated with ridge

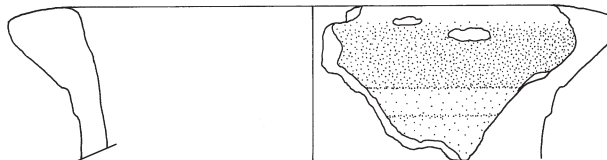

AM28

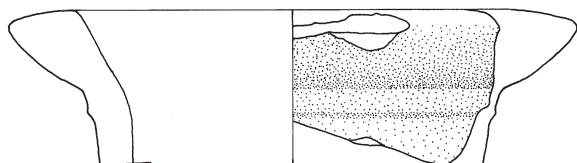

AM29

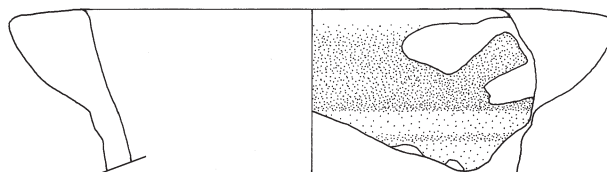

AM30

---

Type 3: outturned

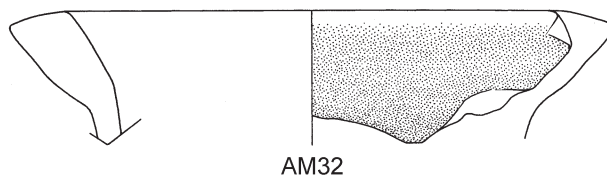
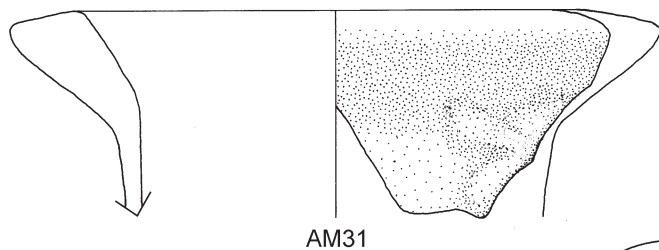

Exception

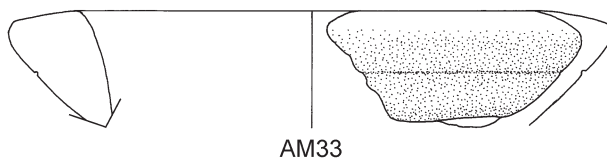

Handle fragments

Type 1: bends directly downwards

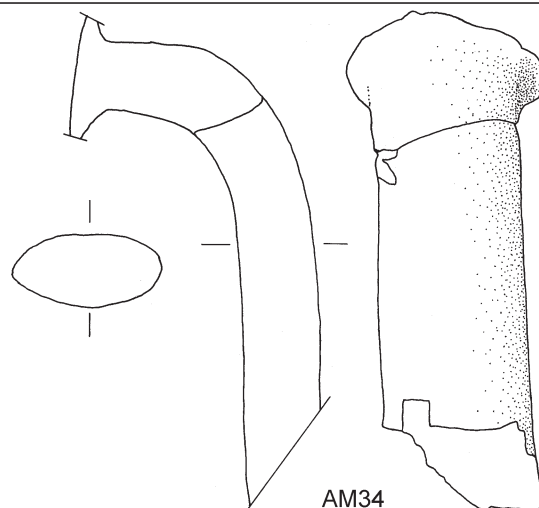

Type 2: slightly curved upwards

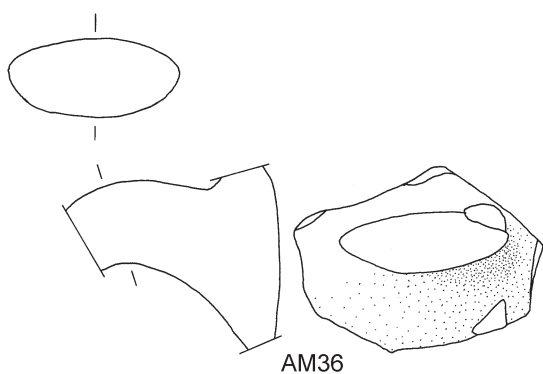

Spikes

Type 1: convex 1

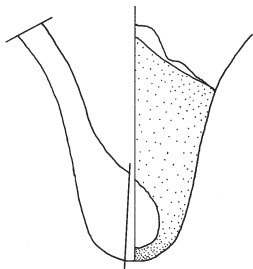

AM38

Type 2: convex 2

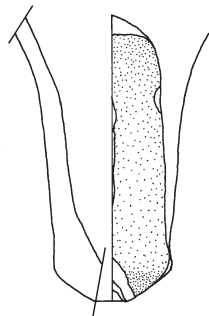

AM39

Type 3: raised 1

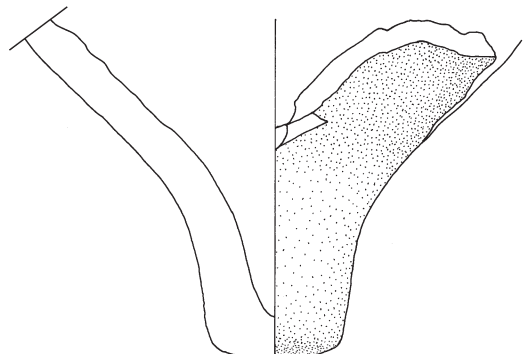

AM40

Type 4: raised 2

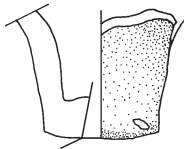

AM41

BLACK GLOSS

Open forms  
Plate

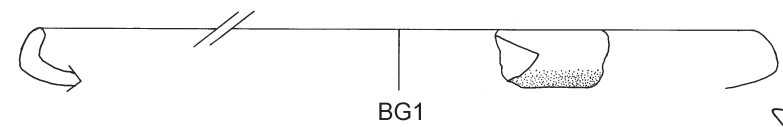

BG1

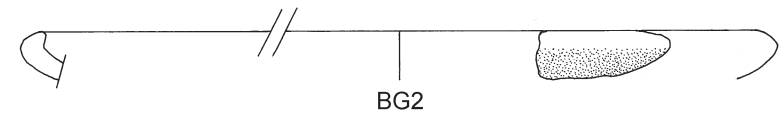

BG2



BG3

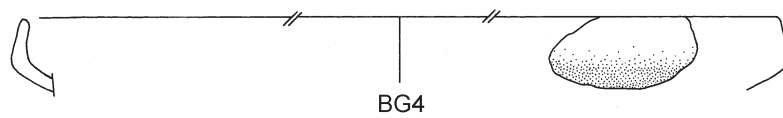

BG4



BG10

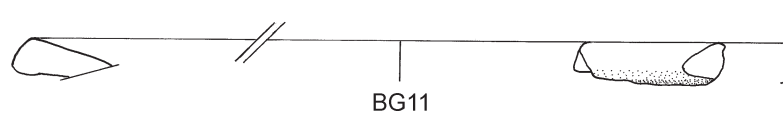

BG11



BG5

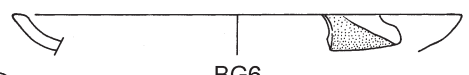

BG6

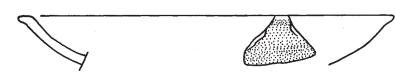

BG7



BG8



BG9

Plate VI

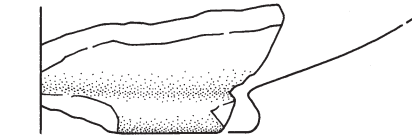
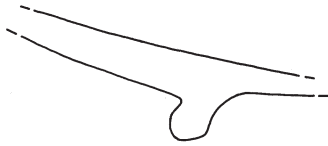

BG12

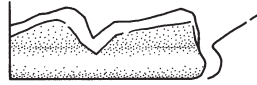

BG13

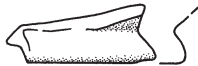

BG16

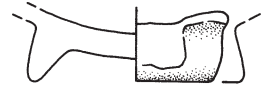

BG14

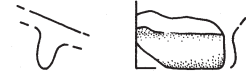

BG15

Bowl

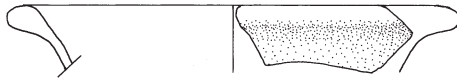

BG17

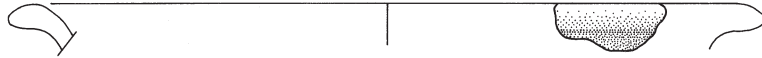

BG18

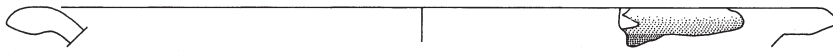

BG19

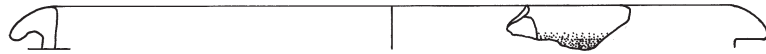

BG20

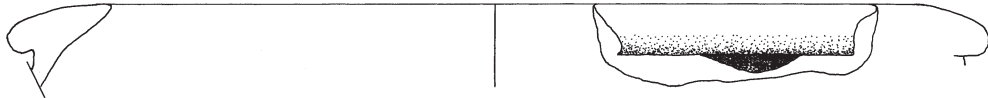

BG21



BG22

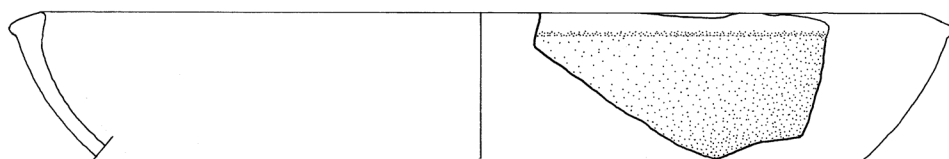

BG23

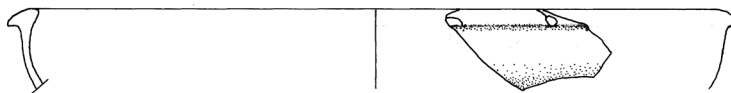

BG24

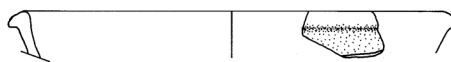

BG25

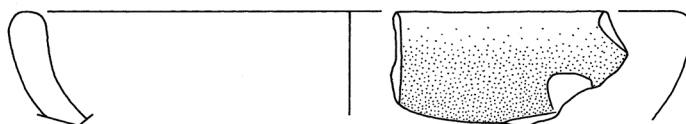

BG26



BG27

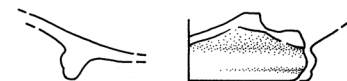

BG29

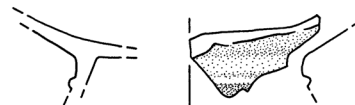

BG30

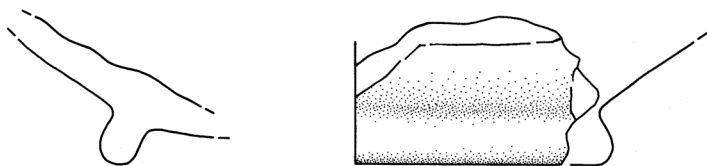

BG28

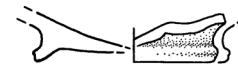

BG31

Cup

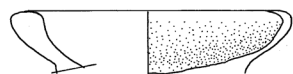

BG32



BG35

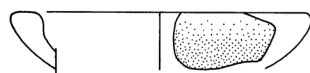

BG33



BG36

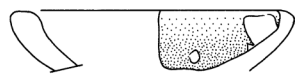

BG34

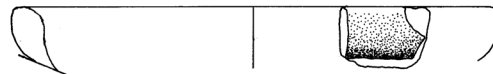

BG37



Plate VIII



BG38

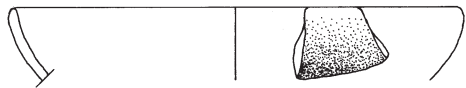

BG39

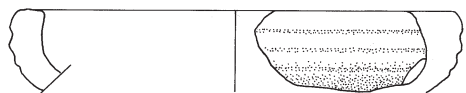

BG40

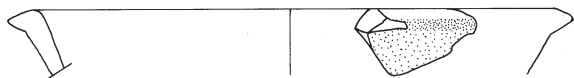

BG41

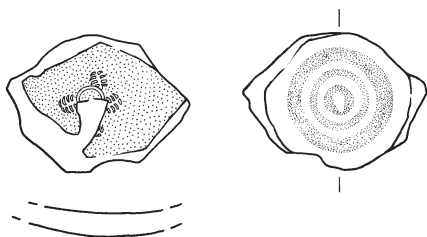

BG47



BG42



BG43



BG44



BG45



BG46

Skyphos

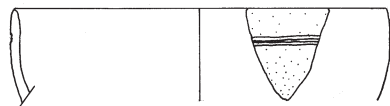

BG48

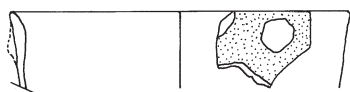

BG49

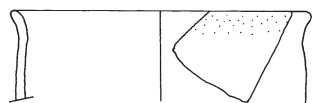

BG50

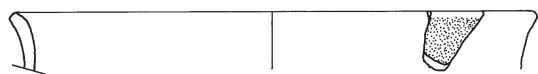

BG51

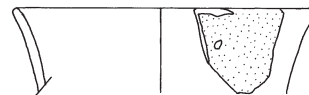

BG52

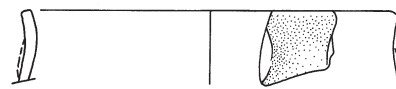

BG53

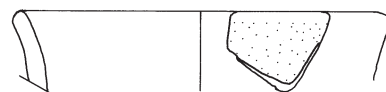

BG54

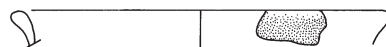

BG55

Plate IX

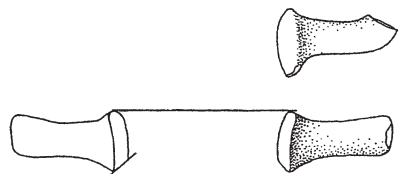

BG56

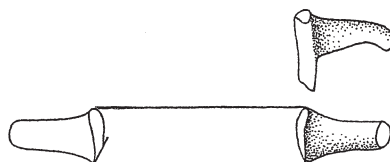

BG57



BG58

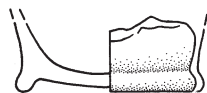

BG63

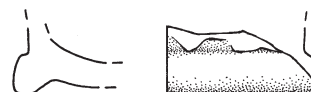

BG66

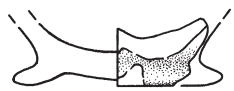

BG59

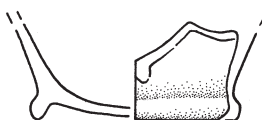

BG64



BG67



BG60

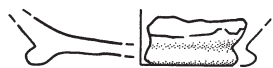

BG61

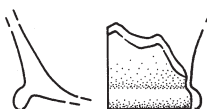

BG65

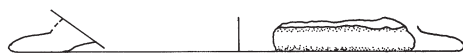

BG62

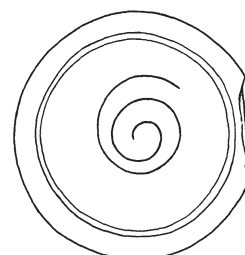

BG68

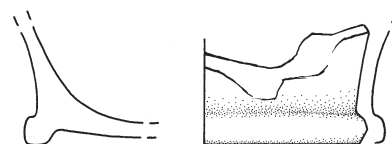
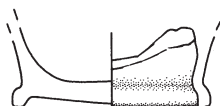

BG69

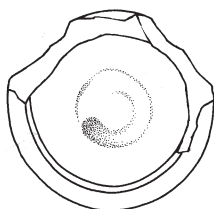

BG70

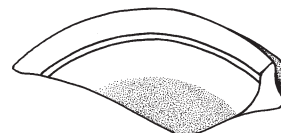

BG71

Plate X

Crater

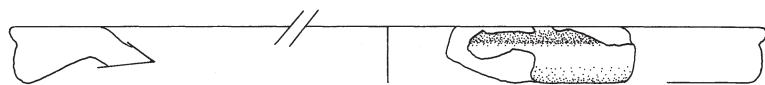

BG72



BG74

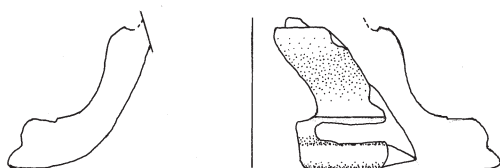

BG75

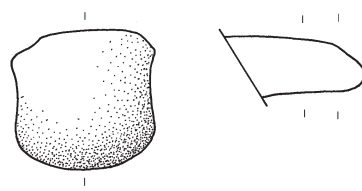

BG73



Closed forms

Jug

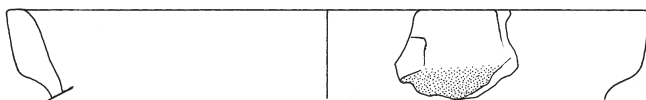

BG76

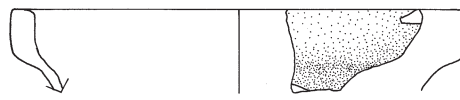

BG81

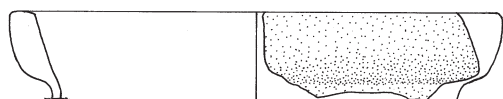

BG77

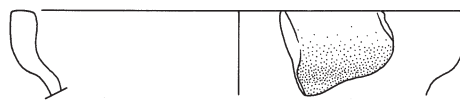

BG82

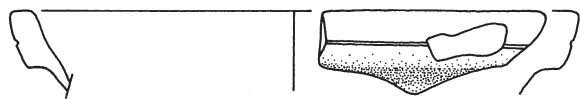

BG78



BG83

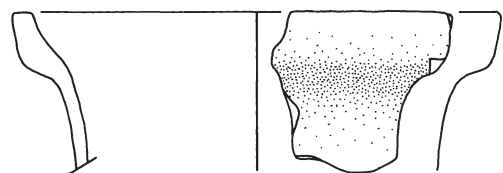

BG79

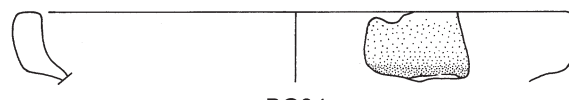

BG84

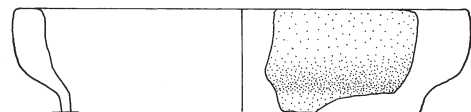

BG80

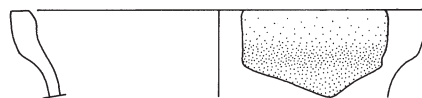

BG85

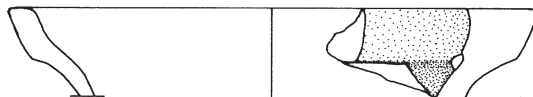

BG86

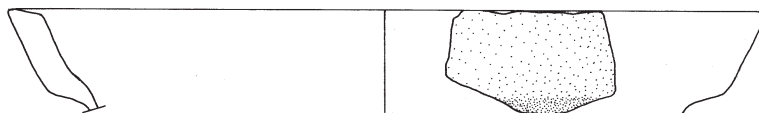

BG87

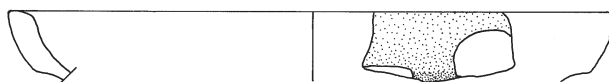

BG88

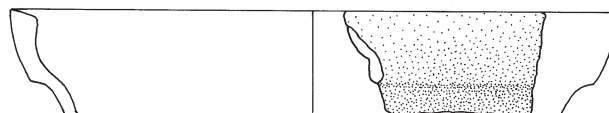

BG89

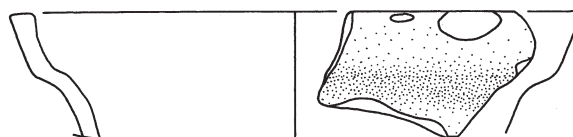

BG90

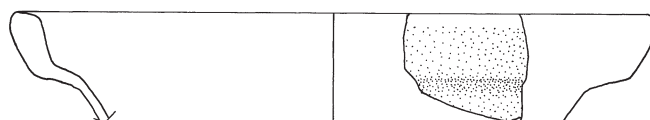

BG91



BG92



BG93

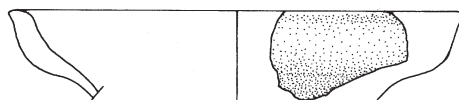

BG94

Plate XII

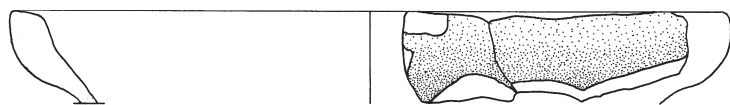

BG95



BG99

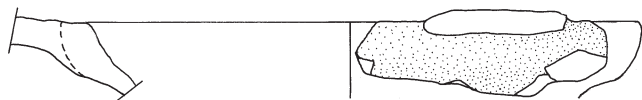

BG96

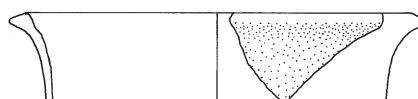

BG100

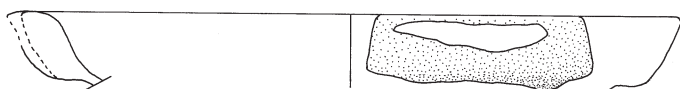

BG97



BG101

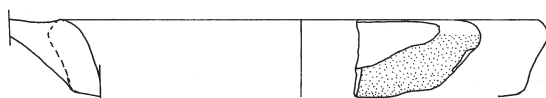

BG98

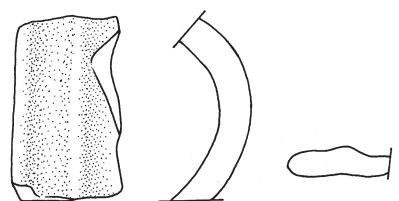

BG102

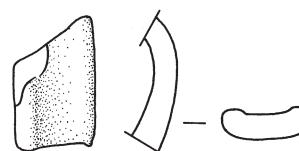

BG103



BG104

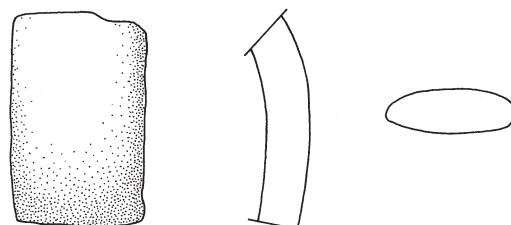

BG105



BG107

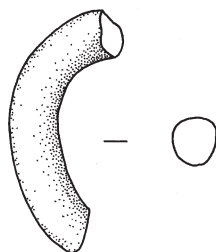

BG109



BG108



BG109

Plate XIII



BG110

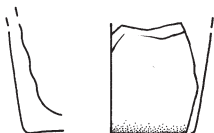

BG112



BG114

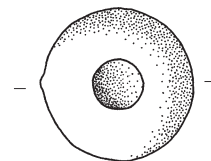
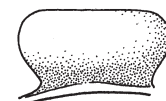

BG116



BG111

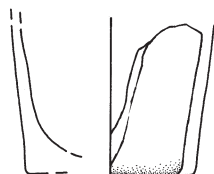

BG113



BG115

*Lekythos*



BG117



BG118

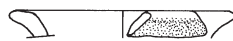

BG119

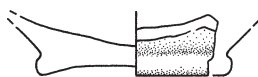

BG124



BG125

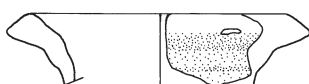

BG120



BG121

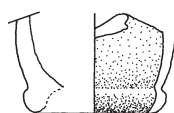

BG126



BG122

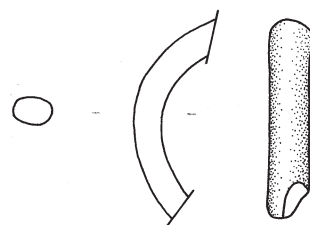

BG123

*Lamp fragment*

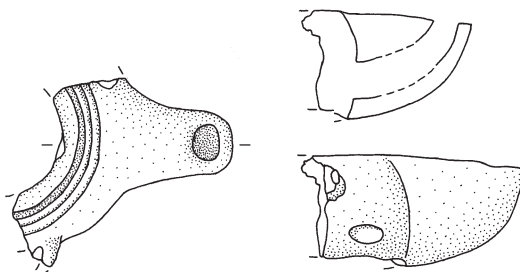

BG127

CERAMICA COMUNE

Depurated clay  
Basin

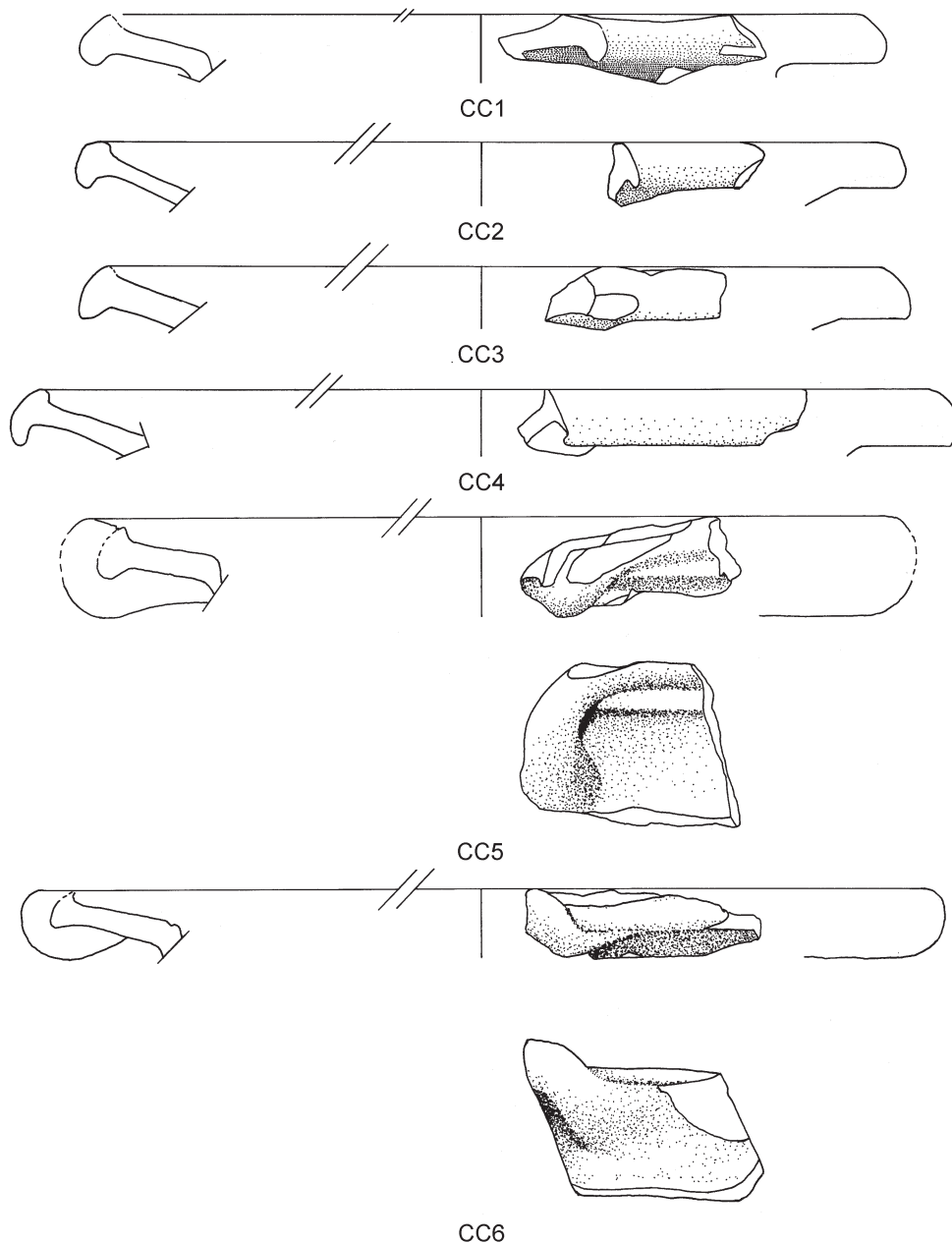

Mortar

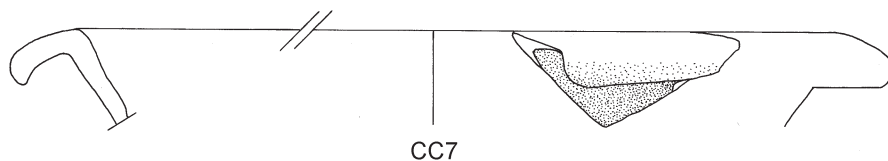

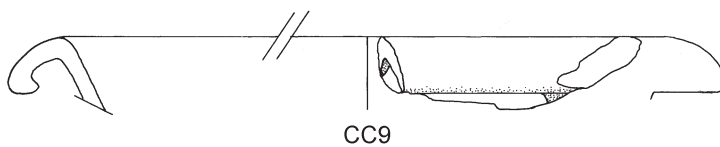
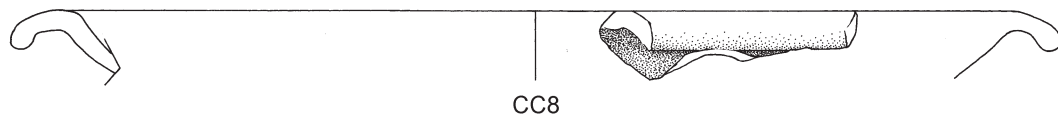

*Cooking pot*

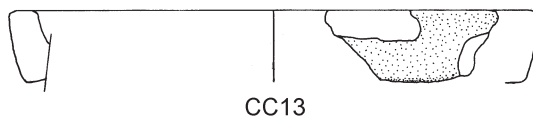
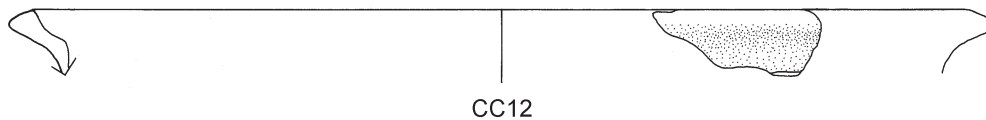

*Storage vessel*

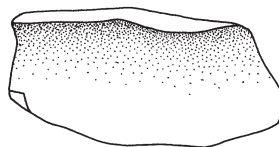
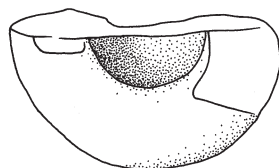

CC15



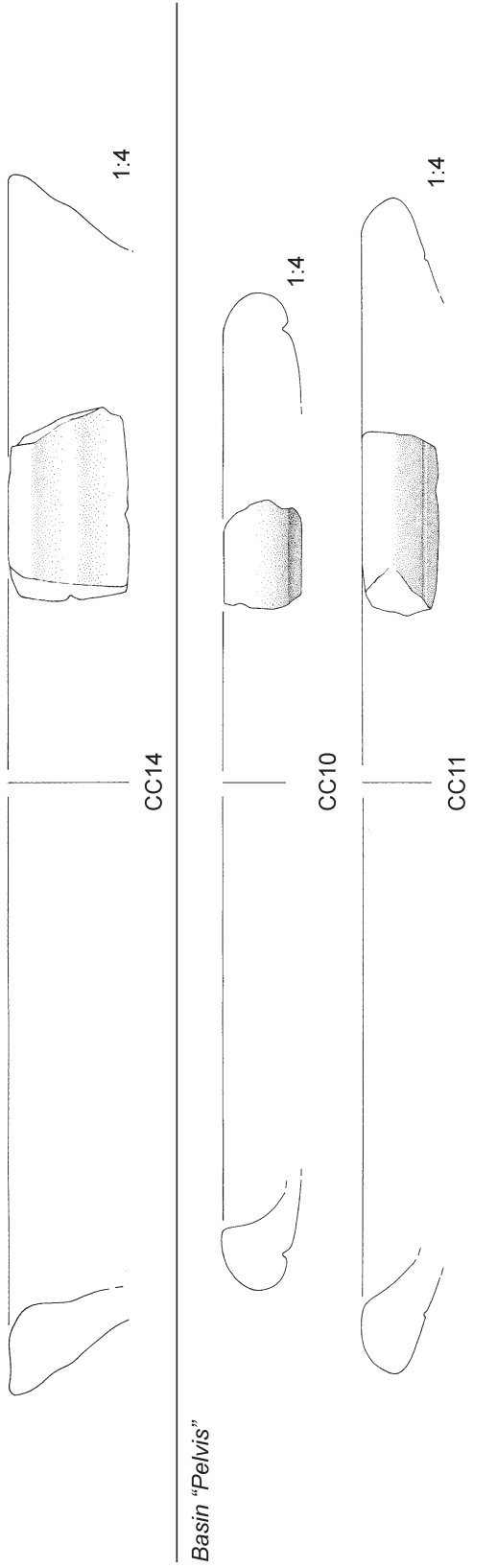

COARSE WARE CLAY

Miscellaneous

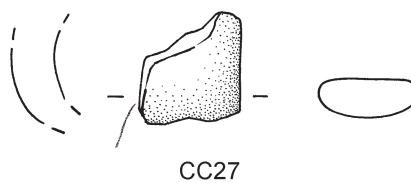
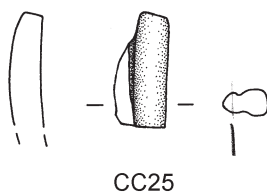
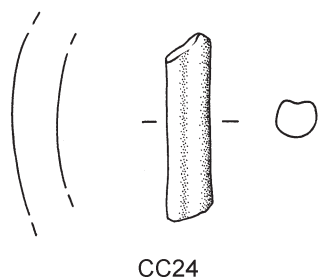
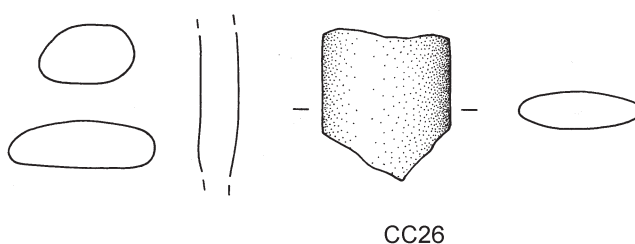
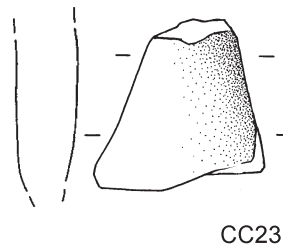
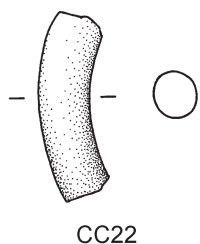
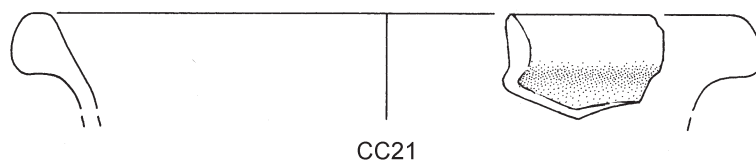
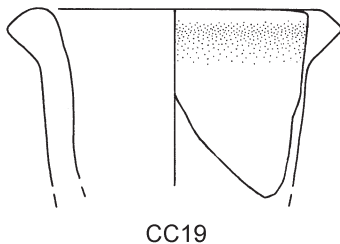
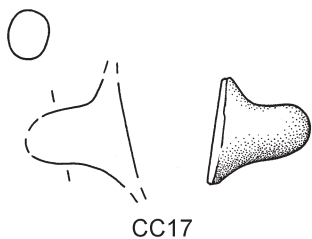
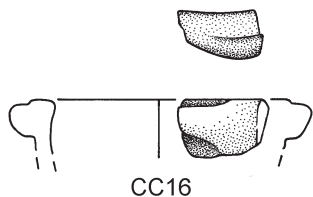
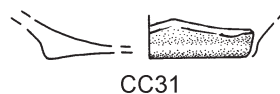
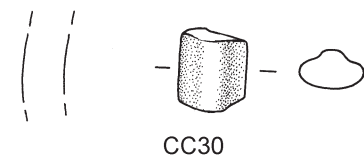
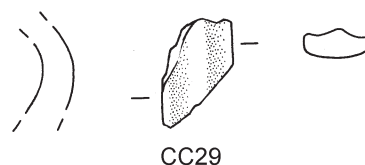
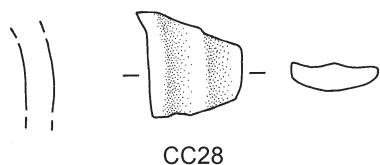
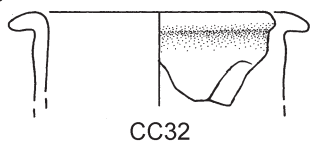

Plate XVIII



Cooking pot  
Chytrai



Pentola

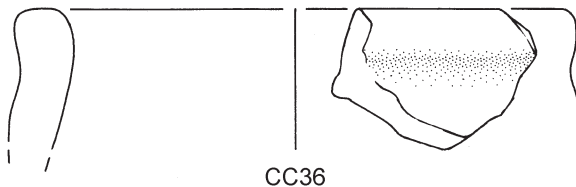
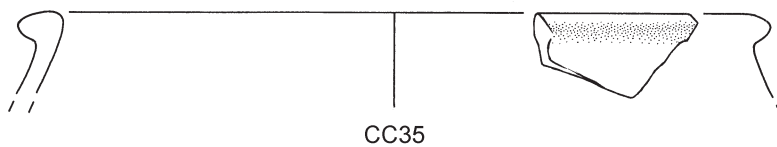
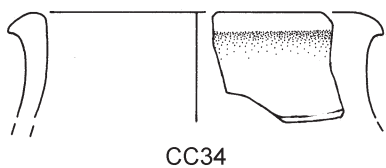

Casserole

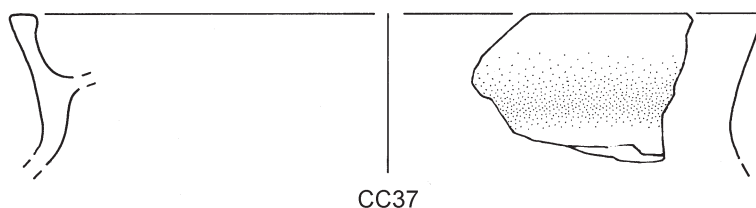

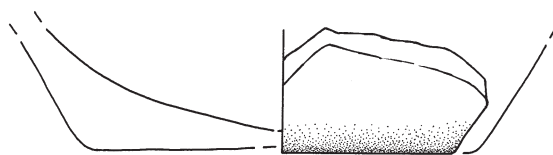

CC39

---

*Storage vessel*

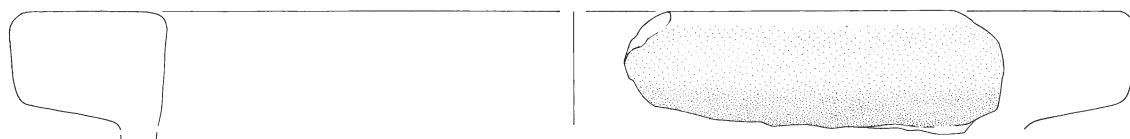

CC40

1:4

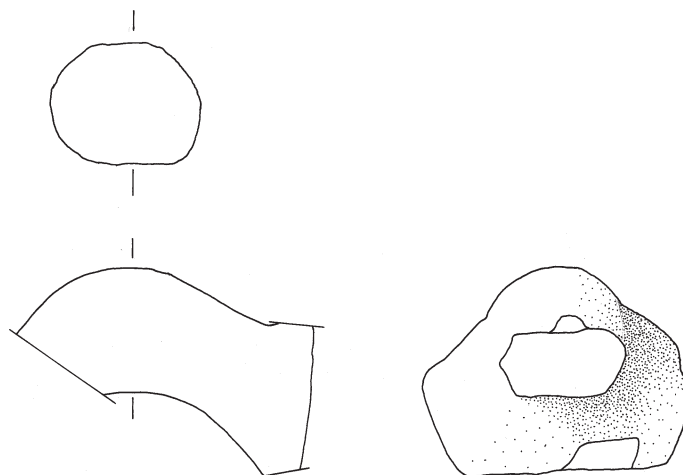

CC41

BUILDING MATERIAL

Plate XX

Tile

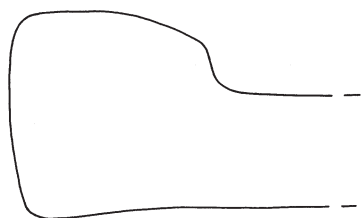

BM1



BM2

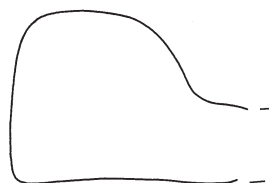

BM3

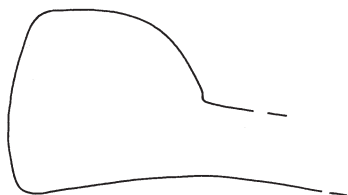

BM4

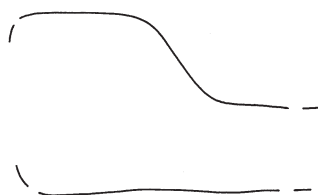

BM5

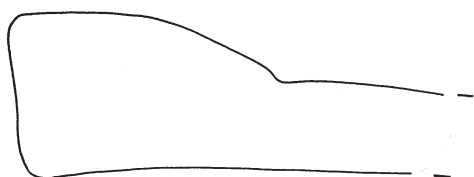

BM6

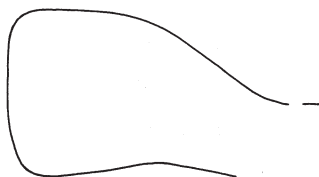

BM7

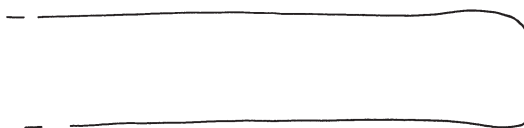

BM8

---

Imbrex

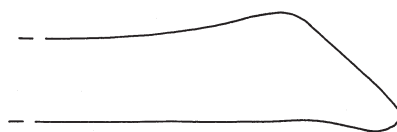

BM9

---

---