

THE DESTROYED *HUNEVED* O2 AND THE ADJACENT TRB FLAT CEMETERY
AT MANDER (*GEM. TUBBERGEN*, PROVINCE OVERIJSSSEL)

J.N. LANTING & A.L. BRINDLEY

Groningen Institute of Archaeology, Groningen, Netherlands

ABSTRACT: In 1957 Dr C.C.W.J. Hijzeler excavated the remains of the destroyed megalithic tomb O2 near Mander. Apart from a few short notes the results have not been published. In 1995 the provincial archaeologist, A.D. Verlinde, re-excavated the site, in order to locate the destroyed tomb precisely prior to the construction of an oblong earthen mound on the site, and to establish the quality of any remaining evidence. Both authors participated in the excavation. The 1995 excavation enabled the complete reconstruction of the ground plan of the megalithic chamber, due to the discovery of the foundation pit of the eastern end stone, and the elucidation of the character of some sub-recent features recorded in 1957. An unexpected discovery was that of a number of TRB flat graves and of pits with TRB pottery adjacent to the megalithic tomb. The finds from the destroyed *hunebed* have been sorted and described, but unfortunately not illustrated either as drawings or as photos due to a lack of manpower and finance. The finds from the flat graves and pits containing pottery excavated in 1995 are illustrated here, however. The decorated pottery from the *hunebed* belongs largely to Brindley's Horizons 3 and 4, but two typical Horizon 5 pots are preserved as well. In the spread of sherds in front of the entrance to the tomb Horizon 2 pottery was discovered, suggesting that the *hunebed* may have been constructed during that Horizon. The pottery from the flat graves next to the *hunebed* belongs partly to Horizon 4, but largely to Horizon 5, indicating that this flat grave cemetery started during the last phase of use of the *hunebed*, but stayed in use for some time after the last burial in the *hunebed*.

KEYWORDS: Netherlands, Overijssel, Neolithic, TRB culture, *hunebedden*, flat graves, pottery, typochronology.

1. INTRODUCTION

In October 1995 an archaeological excavation was undertaken in a field near the Manderstreu northeast of Mander (figs 1 and 2) which was initially meant only to identify the site of the 1957 excavation by the Rijksmuseum Twente, under the direction of Dr C. C. W. J. Hijzeler, of the levelled *hunebed* O2 and to assess the quality of any remaining features. These aims co-incident with the plans of the owner of the land, J. Booiijk of Mander to rebuild the destroyed *hunebed*. He was dissuaded from this by the ROB (*Rijksdienst voor het Oudheidkundig Bodemonderzoek*) because of the costs, safety *etc.* but as an alternative the raising of a long mound on the site had been proposed. Furthermore, the ROB wanted to establish what remains of the site still required protection. (Verlinde, 1995/ 96). The excavation took place under the direction of Dr A.D. Verlinde, and under the on-site supervision of K. Greving, both of the ROB. The two authors of this article were invited to take part because of their expertise in the areas of destroyed *hunebedden* and TRB pottery.

The 1995 excavation showed that, as expected, very little of the ground plan of the 1957 excavation still existed. This was not surprising, as the site of the

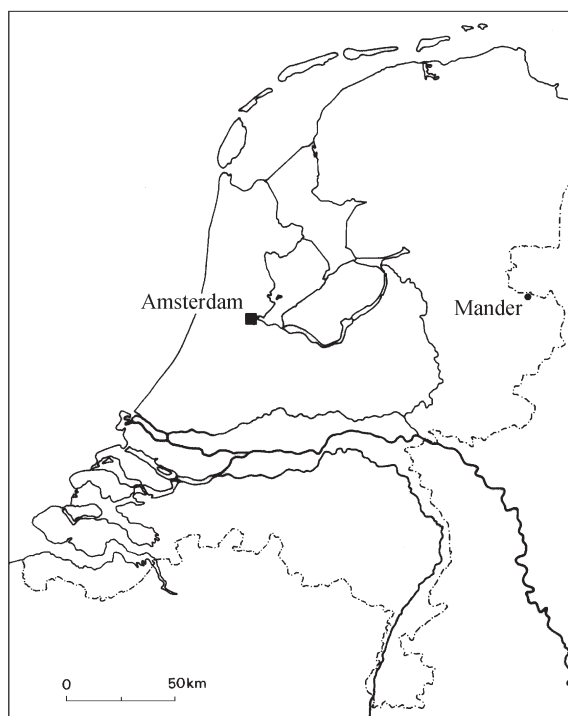

Fig. 1. Situation of Mander.



Fig. 2a. Map of Mander and the Manderstreu (drawing J.H. Zwier).

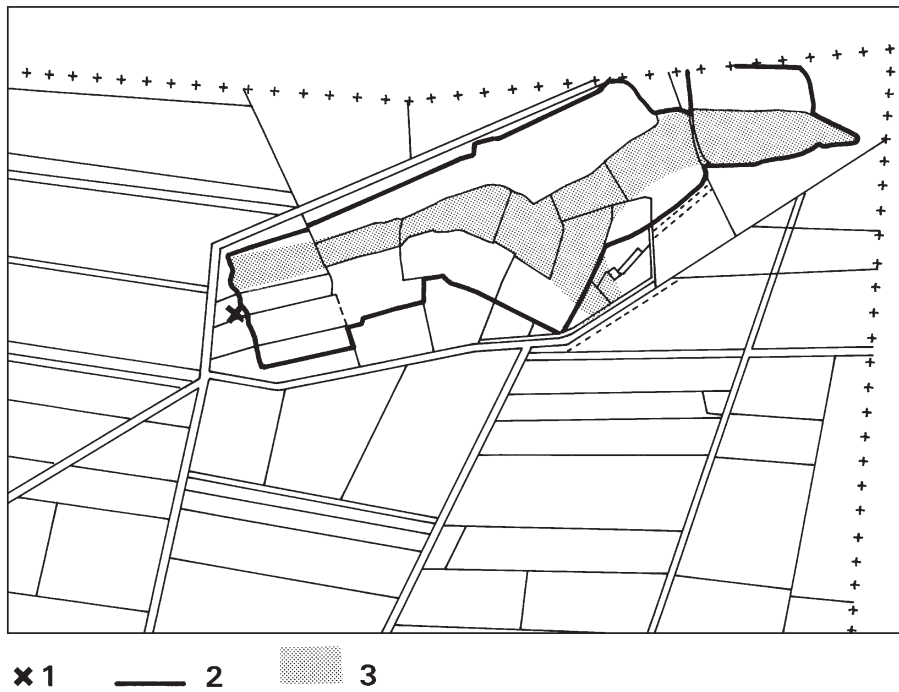

Fig. 2b. Cadastral map of the Manderstreu. Legend: 1. Situation of destroyed Megalithic tomb O2; 2. Outline of the cultivated fields indicated on the Hottinger map of 1790; 3. Remains of the pleni-glacial erosion gully and valley of the Eendenbeek (drawing J.H. Zwier).

excavation had always been visible as a clear yellow patch immediately after the field was ploughed. Furthermore after 1957 it had been possible to plough deeper in that area because the remains of the stone floor were no longer a hindrance. But the 1995 excavation also produced some new information. The character of the 'ditch' which according to Hijzeler cut the east end of the site was resolved and the foundation pit for the end stone was also located. Furthermore, sufficient details of the 1957 excavation were rediscovered to link the previous excavation to the present excavation.

The excavation took an unexpected turn when the owner of the adjacent field on the south side, G. Mensen of Mander, informed us that the 1957 excavation had also extended into his property. In order to check this statement, a trench was opened in this area. This led immediately to the discovery of a large number of sherds in the undisturbed subsoil in an area of 3×2 m at about the site of the entrance through the mound to the former burial chamber. Further excavation revealed a pit with a decorated TRB bowl at a deeper level. When following this, the whole area was cleaned to a deeper level, a deposit of two undecorated TRB bowls was uncovered. At the same time, the trench in Booijnck's field was extended eastwards in order to examine an area of subrecent disturbance in greater detail. To everyone's surprise a well-defined flat grave with a decorated TRB amphora and a possible second grave which had been partially dug away some time in the past, were revealed. As a result it was decided to extend the trench in Mensen's field to the same length as that in Booijnck's field and during this work six other graves and two largely destroyed graves or pottery deposits were discovered. All of these features were excavated. Only a summary of the 1995 excavations has so far been published (Lanting & Verlinde, 1996).

This report describes the ground plan of the former *hunebed* O2, in so far as it can be reconstructed from the photographs of the 1957 excavation in combination with the field drawings and some brief published notes. The finds from the excavation have in the meantime been largely sorted and described but have not been drawn due to lack of resources (Verlinde, 1995/1996: p. 24). It is possible to date the use of the burial chamber (Ufkes, 1993). In addition, this article will deal with the features and finds from the additional excavation of 1995. Fortunately, it has been possible to have this material drawn.

2. LOCATION

Hunebed O2 and the adjacent flat grave cemetery are located on the western slope of a north-south oriented part of the Ootmarsum-Uelsen-Itterbeck ice-pushed ridge (Van den Berg & Den Otter, 1982: fig. 1), immediately south of a narrow elongated valley-like area, the so-called Manderstreu (Hijzeler, 1966: pp. 18–21). A small stream, the Eendenbeek, previously ran through this area. This had its source higher up on the ridge, across the German border. Nowadays, the stream is practically dry (fig. 2a). The geology and morphology of this part of the ridge are well known (Stapert, 1982; Van den Berg & Den Otter, 1982). It consists of marine deposits of Tertiary age which were pushed up by a glacier during the last stadial of the Saalian glaciation. While the ridge was being pushed up, an outwash fan formed on its western flank. Later, the ice also spread out over the ridge, partially eroding the pushed up deposits. When the ice retreated, it left behind glacial till (*keileem*) on both the flanks and the top of the ridge (Van den Berg & Den Otter, 1982: fig. 3). Further erosion took place, especially during the Weichselian. During the pleniglacial phase of the Weichselian deep erosion gullies in the flanks of the ridge were formed (Stapert, 1982: fig. 2; Van den Berg & Den Otter, 1982: fig. 4). The lower parts of these are often filled with younger sediments but they are easily recognisable higher up. The small valley of the Eendenbeek at Manderstreu is the remains of such an erosion gully. The boulder clay deposits which were left behind by the glacier were heavily eroded, so that the clay was largely washed away leaving the sandy stony soils (*keizand*) behind. The solifluction fans are also important. These had formed on the lower parts of the slopes (Van den Berg & Den Otter, 1982: fig. 3). In the vicinity of the *hunebed* and the flat grave cemetery there appear to be deposits belonging to both the outwash fan which formed during the pushing up of the ridge and to the solifluction fans that were formed during the Weichselien. The stones used for building the *hunebed* were undoubtedly found in the direct neighbourhood and were remnants of the boulder clay layer which had disappeared completely.

Because of its wetness the Manderstreu was probably an attractive locality in the Neolithic for grazing while on the higher ground cultivation was possible. The Manderstreu seems to have been an attractive area during later periods as well. According to the *Markeboek of Mander, Vasse and Geesteren* (1498–1647) which was cited by Hijzeler (1966: p. 21) two pieces of land were sold in 1576, undoubtedly for reclamation. It is not clear whether reclamation had only just started or

whether it had been going on for some time, but it is a fact that Hottinger's map of c. 1790 (Versfelt, 2003: map 53) shows both the erosion gully as well as several adjacent fields in cultivation on its higher south side (given together under the name 'Mandersche Streu'). The same fields can still be recognised by their shape on the cadastral map (fig. 2b).

The *hunebed* lay just outside the area which had been brought into cultivation. Hottinger's map shows no trace of the *hunebed* or of a mound on the site. It is not clear how much value can be attached to this. On the maps of southeast Drenthe which were made by the same military surveyors at the same time, most of the *hunebedden* are shown. We are inclined to conclude that the *hunebed* O2 was levelled shortly after 1734, as a result of the great demand for stone for the protection of the new sea dikes which was also the cause of destruction of many German *hunebedden* (see Bakker, 1979: p. 20 and note 2:10). Unfortunately the *Markeboek of Mander* covering this period is no longer in existence. The sale of the stones from the *hunebed* would undoubtedly have been recorded.

3. THE EXCAVATION OF THE DESTROYED HUNEBED O2

3.1. Background to the excavation of 1957

When Hijzeler was investigating a number of burial mounds in the summer of 1957, in the southern part of the 'Noordelijke Mander Heide' (see *Archeologisch Nieuws* 1957: *107, *130, and *225–226) according to Stroink (1962: p. 48) he was informed by one of the labourers of sherds being found in a small potato field near the Manderstreu. On closer inspection, it appeared that these were TRB sherds (see Dingeldein, 1964 of which chapter 19, 'Langs de heuvelen der heidenen' had undoubtedly been edited by Hijzeler to include the latest excavation results). Further questioning revealed that the owner (since identified as Jens Blokhuis, thanks to the fact that his nephew, Jan Blokhuis, worked on the 1995 excavation) had reclaimed the area himself shortly after the end of the Second World War, and at that time had found sherds and field stones which he had thrown away, and three large boulders which he had taken away and used in the floor of a pig sty. He had not thought it necessary to inform the museum in Enschede of these discoveries (Hijzeler, 1966: p. 24, note 36).

Already in the late summer of 1957 (see *Archeologisch Nieuws* 1957: *225–226) Hijzeler had the opportunity to carry out an excavation which showed

that this was the site of a former *hunebed*. Very little was published about this work other than a few short summaries and notes in journals and books, either written by Hijzeler or based on information from him (*AN* 1957 *225–226; Jaarverslag Oudheidkamer Twente (OKT) 1957: p. 3; Hijzeler, 1966: p. 24, note 36; 1970: p. 44; 1980: p. 66; 1981: p. 27; Stroink, 1962: p. 48; Dingeldein, 1964: pp. 233–234; Bakker, 1979: pp. 155 and 174, note 7:5). The excavation documentation is equally scanty; nothing more than three field drawings and a hand-full of photos appear to exist nor does there appear to be an excavation diary. However, thanks to the photos it is clear how the excavation was carried out and how the field drawings should be interpreted. The photos also show the shape of the excavation trench and even make it possible to reconstruct its dimensions to a certain degree. They even make it possible to fit in a drawing of a pit with stones whose location is not indicated on the field plan itself.

According to oral information from the former Dr. A.L. Hulshoff (per 1–1–1956 keeper and from 1–9–1967 director of the Rijksmuseum Twente) and the first named author (autumn '83/spring '84), the excavation was carried out by museum personnel. Indeed there is no reason to believe that the ROB provided assistance in the form of the field technician and draughtsman A. Bruijn as Bakker (1979: p. 155) has suggested. Bruijn had assisted in the excavation of the burial mounds earlier that year and had been responsible for the excavation plans. The field drawings of the *hunebed* excavation are sketchy and not coloured and do not bear comparison with Bruijn's other field drawings and furthermore, the notes on the excavation plans are not in Bruijn's handwriting. According to Hulshoff the soil from the levelled burial chamber was collected in wheel barrows and then sorted manually for sherds, flint *etc.* Although this allowed in principal for the material to be collected by grid, this was apparently not done on a systematic basis. No grid is indicated on the field drawings for instance. The find spots of four axes are recorded on the ground plans but the impression is that these were added later because those from level 1 and level 2 seem to be interchanged. The depths of the pits must also have been added later.

3.2. The 1957 excavation

The ground plans of 1957 show three levels of excavation within the destroyed burial chamber. These are recorded on a single piece of graph paper, beside each other, with the complication that the second level is turned at 180° in relation to the other two plans and also has been given a wrongly orientated north point.

Drawn on a separate sheet of paper are the three corresponding levels of a feature on the west side of the chamber, which we interpret as the extraction pit of the western end stone. These plans can be reconciled with the large general ground plan. This is not the case, however, with the plan of a pit with stones and several concentrations of field stones whose grid does not coincide with that of the other plans. The plan of the second level shows the northern and eastern edge of the excavation trench and of seven pits outside the burial chamber on the north side. Luckily good photos exist of the three excavation levels and of the pit with stones. These make it possible to reconstruct to a large extent the boundaries of the excavation trench, to locate fairly precisely the pit with stones and a photo showing the detail of a section through an extraction or foundation pit, and furthermore to show what was recorded on the ground plans and what was not.

The first level was photographed immediately below the plough soil. The photo (fig. 3) is taken from the east, and shows an excavation trench with a stepped edge on the north side and an extension in the middle of the south side. On the west side the excavation surface had not been fully cleaned. On the east side a narrow ditch is to be seen which runs at right angles to the long axis of the destroyed *hunebed* and across its eastern end. There are indications that a side trench joined the northwest corner of the main trench. The destroyed *hunebed* shows up as oblong dark area with many field stones and pieces of stone, on either side edged by irregular bulges of a darker colour which have clearly less stone in them. On the west side approximately on the long axis but separate from the remains of the chamber are a pair of irregular shaped pits close together, possibly the remains of a single large pit at a higher level. For someone who has seen destroyed *hunebedden* before (the first named author excavated the remains of the *hunebedden* G2 and G3 on the Glimmer Es *gemeente* Haren, D32a and D36b at Odoorn and D43a on the Schimmer Es at Emmen and was present during part of the excavation of D32d at Odoorn and is familiar with the documentation of the excavations of the levelled *hunebedden* of D6a at Tinaarlo (Brindley, Lanting & Neves Espinha 2001/2002) and D54a a Spier and D54 b and c at Hooghalen) the remains are easily understandable. The field stones and pieces of stones are not *in situ* but originated from destroyed parts of the chamber floor and from dry-stone walling between the side stones. The bulges are the extraction pits of the missing side stones, the separate pit on the west side is the remains of the extraction pit of the western end stone. Extraction pits are recent pits which were dug when

the side stones were removed and should not be confused the original foundation pits of the side stones. Experience at the sites of other levelled *hunebedden* has shown that the foundation pits of side stones are in general either not visible or only barely visible but that the chocking stones at the bases of these pits are usually still recognisable. Extraction pits lie approximately on the sites of the foundation pits and are usually larger and also more irregular in shape than the foundation pits themselves, depending on the method with which the stone was extracted/removed. An extraction pit may even lie beside the original foundation pit.

The plan of the upper level (fig. 4) only shows the outline of the burial chamber and the extraction pits but the plan is incomplete on the south east side. Apparently Hijzeler found this part too unclear to be planned. The edges of the trench and features in the soil outside the burial chamber were not recorded except for the patches which according to us are the remains of the extraction pit of the western end stone. Hijzeler was puzzled by the identity of these pits, and wrote in one of his brief notes (Hijzeler, 1970: p. 44) that the site of this end stone had been destroyed by the reclamation works. Several levels are given on the ground plan which in part must have been added later. The levels are relative to an unknown point in the neighbourhood. Furthermore, twice the term *second floor* ('*tweede vloer*') is recorded, which could only have been added after the discovery of the original chamber floor. In almost every short note mention is made of these two floors, although according to us this is incorrect. This second floor consists of the dispersed stones in the disturbed filling of the chamber immediately above the remains of the actual chamber floor and in part consisting of the stones of the destroyed part of this floor. Hijzeler was clearly of the opinion that a second floor had been present because Van Giffen claimed to have found second floors on several occasions, for example in D21 and D22 at Bronneger, D30 at Exlo (Van Giffen, 1925/27, text part II: pp. 231–259, resp. 207–229, and pls. 144–146, resp. 135–136). The so-called second (or higher) floor in these *hunebedden* are no more than the dispersal of stones and pieces of stones which were all planned together although the actual heights varied. There is no question of floors over the full length and width of the chambers (see also Bakker, 1992: p. 29).

The photo of the second level (fig. 5) is also taken from the east, from a slightly higher view point and from further away. More of the surrounding area is visible. It is clear that the excavation took place in a field of potatoes which had not yet been lifted. The



Fig. 3. Excavation level 1 (photo OKT, Enschede).

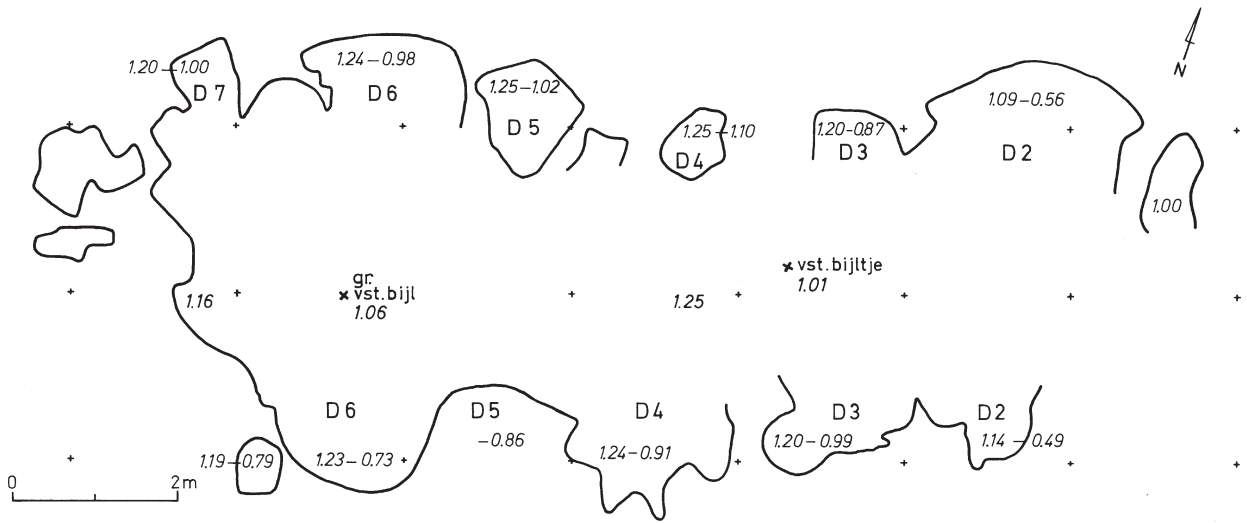

Fig. 4. Excavation level 1, after field drawing of 1957 (drawing J.H. Zwier).



Fig. 5. Excavation level 2 (photo OKT, Enschede).

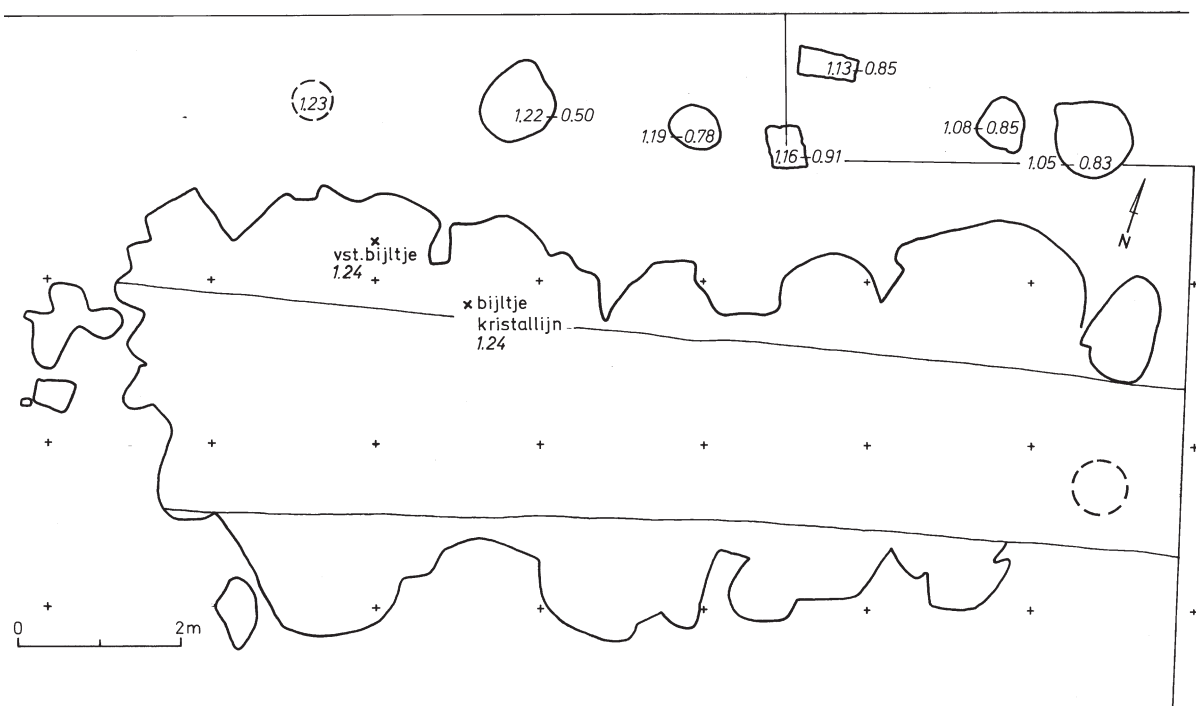

Fig. 6. Excavation level 2, after field drawing of 1957 (drawing J.H. Zwier).

potatoes in the field on the adjacent south side had also not been lifted. The northern edge of the excavation trench is now straight, on the western side the surface of the trench has now been cleaned and in the northwest corner has even been deepened. There are two piles of loose earth however. In the northwest corner parts of the side trench running at right angles can be seen. The whole of the extended part in the middle of the south side is now visible. It appears that this extension lay in the adjoining field. The reason for the extension of the excavation trench was probably to document the surfacing of the layer of iron pan under the edge of the former mound. The narrow ditch at right angles to the long axis of the *hunebed* is still present at the east of the trench. It is now clearly visible that this is dug into a dark-coloured, approximately north-south running disturbance. This is apparently the trench (Dingeldein, 1964: p. 233) or ditch (Hijzeler, 1970: p. 44; Bakker, 1979: p. 174 note 7:5, where this ditch is incorrectly referred to as being on the west rather than on the east side, possibly because of the wrongly positioned north point on the plan of the second level), which must have destroyed the remains of the *hunebed* on its east side. The photo shows portions of the floor still intact in several places, especially in the western half. Elsewhere the stones are more spread out and it is questionable whether they are still *in situ* in all cases. The extraction pits show up more clearly at this second level, but on the south east side an extraction pit appears to be missing at the point where the ditch starts. On the north side of the *hunebed* seven features, some with dark fill and others with pale fill are visible. These are apparently the pits that Hijzeler (1970: p. 44) had in mind when he suggested that old grave gifts had been removed from the burial chamber and buried in pits outside the *hunebed*. In a letter of 29-1-1973 quoted by Bakker (1979: p. 174, note 7:5) Hijzeler rejects the idea that these were traces of a stone kerb. The photo suggests that only the chamber itself was excavated down further and the edges of the excavation trench remained unaltered. Notes such "top of as second floor, 1.25", and "small flint axe 1.01" only 0.5 m apart, make it clear that locally a difference in height of up to 20 cm or more existed between the first and second level, although it could be different in other places.

Only the outline of the chamber and the extraction pits are shown on the field drawing of level 2 (fig. 6). The stones of the chamber floor are not shown individually but two lines on the plan appear to indicate the edges of the floor. The seven pits north of the chamber which are visible on the photo are shown and the edge of the excavation trench is indicated, prob-

ably to the beginning of the side trench in the NW corner. The edge of the trench on the east side is also shown probably coinciding with the western side of the narrow ditch over the east end of the chamber. No contour line is drawn in the southeast corner east of D2 (south), as was also the case with level 1. It is obvious that Hijzeler could not make up his mind as to whether there was an extraction pit here or not. A fair number of scattered field stones are visible here on the photo (fig. 5). The straight line which is shown on the field drawing as marking the edge of the floor does indeed continue to the edge of the excavation cutting. It is far from clear, however, that east of D2 (south) the field stones are *in situ*. In our opinion these could be floor stones in a secondary position obscuring an extraction pit. Hijzeler did record a small round area of disturbance with a dotted line and a question mark. This certainly lies too far inside to have been an extraction pit. This disturbance is not visible on the photograph. The levels and the depths of the pits north of the burial chamber have been indicated. Other levels were not recorded with the exception of those of two axes but these could have been found during the excavation of the chamber, and do not necessarily indicate an excavation surface.

On the next photo (fig. 7) the chamber floor has been removed and the surface between the extraction pits has been lowered in relation to the adjacent areas. This photo had been taken from the northwest. The excavation trench appears to have been partly back-filled on the west side in the meantime.

There are two photos from the final stage in the excavation, both taken from the northeast. The only difference is the presence of stakes in the extraction pits in one photo which are missing from the other. As this gives an idea of Hijzeler's interpretation, the photo with the stakes is reproduced here (fig. 8). The level inside and outside the extraction pits is now approximately the same. Several of the extraction pits have been sectioned. Most remarkable is that in the section of the trench through extraction pit D2 (south) and north of extraction pit D3 (south) a pit is visible that is not indicated on the field drawing and that almost certainly is the foundation pit of D3 (south). The photo is also important because it gives a better view of the ditch on the east side, which is now broader and deeper than it was earlier. At the base of the ditch a division between two recent areas of disturbance has now become visible which at least partly seem to be two extraction pits. The southerly of the two must be the until now unrecognised extraction pit for D1 (south), which is visible both in the main excavation surface and in the base of the ditch. The northern pit

co-incides partly with the smaller extraction pit D1 (north) of the field drawings. In the base of the ditch both pits join up with the at this level narrower remains of the 'trench' or 'ditch'. On the southwest side of the chamber and west of the easily recognisable extraction pit D6 (south), a strangely shaped cutting with edges at right angles is visible. Fortunately, there is also a detailed photo of this feature (fig. 9). It consists of a group of field stones which is not shown on the plans which are apparently in the undisturbed subsoil or in a faintly coloured pit. These are almost certainly the chocking stones in the foundation pit of what Hijzeler would have called D7 (south). No clear extraction pit was visible in the uppermost excavation surface. In the second excavation surface there is a small bulge in the southwest corner of the destroyed chamber which may have been the extraction pit of this stone. Hijzeler apparently did not recognise the chocking stones for what they were because he did not place a stake in this feature when taking the photo of level 3 (fig. 8). With the help of the features which can be recognised both on the photo and on the plan of level 3 (the straight section face through the extraction pits D2 and D4 (south) and the unmistakable shape of D6 (south, in particular) it is possible to establish the approximate site of the foundation pit for D7 (south), and to indicate it on the plan (fig. 14).

The field plan of level 3 (fig. 10) apparently corresponds with the excavation surface of the last taken general photo (fig. 8), to judge from the manner in which the edges of a number of the extraction pits is shown in places with a dashed line. These parts were apparently already dug away before the excavation surface was drawn. The plan gives no additional details, apart from a few stones in and beside extraction pit D4 (south). The depth is given for the small area of disturbance shown with a broken line in the southeast corner of the chamber which shows that this disturbance was fairly shallow. The clearly visible extraction pit in the south-east corner on the photo is not recorded.

Finally the documentation includes a couple of photos and a field drawing of a pit with stones and a few concentrations of stones in the immediate neighbourhood. The site of the pit and the stones cannot be established on the basis of the drawing but they can be with the help of the photos, or at least approximately. On the photos (fig. 11a and b) the face of the north side of the excavation trench, the side trench which runs off the northwest corner at right angles, the deeper part of the excavation surface along the western edge of the excavation trench and also the western extremity of the chamber is visible. From this it is clear that

the pit and the concentrations of stones lay northwest of the destroyed *hunebed* and that the most easterly field stones were roughly north of the extraction pit of the western end stone. In figure 14 field drawings and evidence from photos have been combined to an overall plan of the 1957 excavation.

3.3. The excavation of the remains of the *hunebed* in 1995

In 1995 a large part of the 1957 excavation trench was opened again, but adjacent areas were also examined along the west side but especially on the east and southeast sides (fig. 12). Scarcely any traces of the *hunebed* remained although after the 1957 excavation extraction pits which had been dug out and backfilled were left. There appeared to be traces of only the three deepest pits, namely the extraction pits for D2 (north) and D2 (south) and from the easternmost of the seven pits north of the *hunebed* (fig. 12). In addition, there was a large rectangular pit of c. 6.5×3.5 m which largely corresponded with the broader and deeper ditch on the east side of the former *hunebed* as was visible on the photo of level 3 (fig. 8). But apparently this ditch was extended towards the north and east after the photo was taken. The fact that within this rectangular area of disturbance a smaller right angled area of more recent disturbance (at the base of which lay a large quantity of building rubble) was present caused some difficulties. At first the smaller disturbance was considered to be Hijzeler's trench and the larger one as Hijzeler's ditch but that did not fit in with the details on the photos and the distances to Hijzeler's dug out extraction pits. It has to be assumed that some time after 1957 by pure chance a square hole was dug on the same spot as Hijzeler's trench to bury building rubble. The rediscovery of the three extraction pits and the right-angled, flat-bottomed pit made it possible to tie the excavation of 1957 into that of 1995. What is also important in this respect is, that the reconstructed southern edge of the 1957 excavation trench appears to coincide approximately with the boundary between the two fields as it was surveyed in 1995, and the extension of the 1957 excavation cutting was indeed situated in the neighbouring plot of Mensen. When the rectangular disturbance (Hijzeler's deepened area or broad trench) was dug out and cleaned, it turned out that the extraction pit or probably even the foundation pit of the eastern end stone was still preserved in the subsoil (fig. 13). This feature had a deepest point of 41.55 m +NAP, or in Hijzeler's terms c. 0.15+. This foundation pit was therefore deeper than any of the other extraction pits. Why Hijzeler did not see

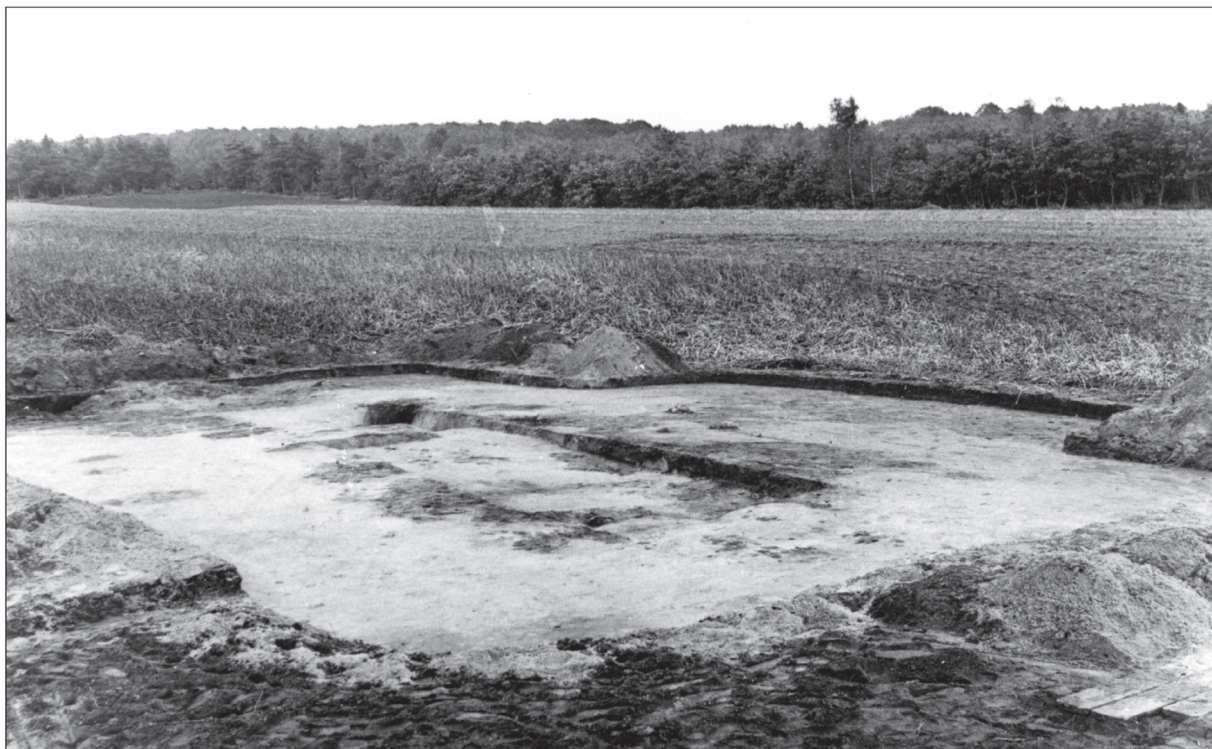

Fig. 7. Excavation level 3, first stage (photo OKT, Enschede).



Fig. 8. Excavation level 3, second stage (photo OKT, Enschede).



Fig. 9. Section through pit with stones, the location of which is visible in figure 8, in the background (photo OKT, Enschede).

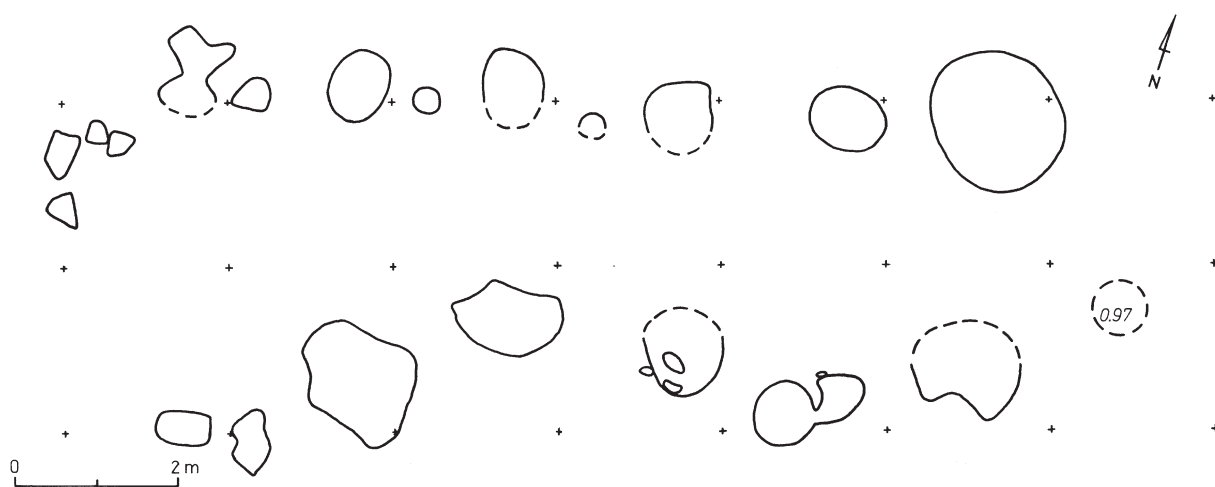

Fig. 10. Excavation level 3, after field drawing of 1957 (drawing J.H. Zwier).



Fig. 11a. Pit with stones, and stone concentrations NW of destroyed chamber, seen from the southwest (photo OKT, Enschede).



Fig. 11b. The same area, seen from the west. The northern edge of the excavation trench and the NW-corner of the destroyed chamber are visible (photo OKT, Enschede).

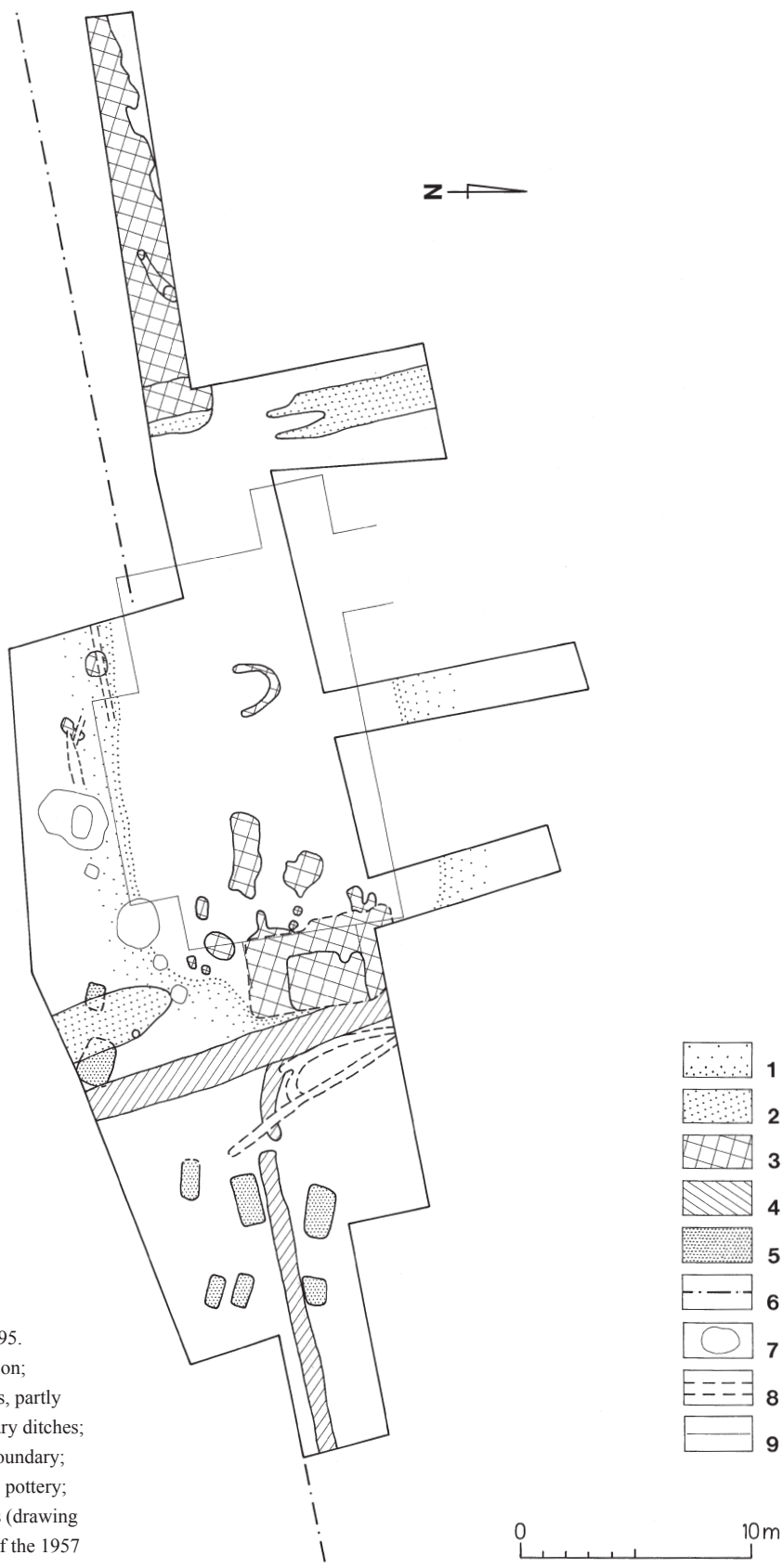

Fig. 12. The excavation trench of 1995.
 Legend: 1. Edge of iron pan infiltration;
 2. Cart tracks; 3. Recent disturbances, partly
 caused in 1957; 4. Subrecent boundary ditches;
 5. TRB flat graves; 6. Recent field boundary;
 7. Outline of invisible pits with TRB pottery;
 8. Plough marks and animal burrows (drawing
 K. Greving/J.H. Zwier); 9. Outline of the 1957
 excavation trench.

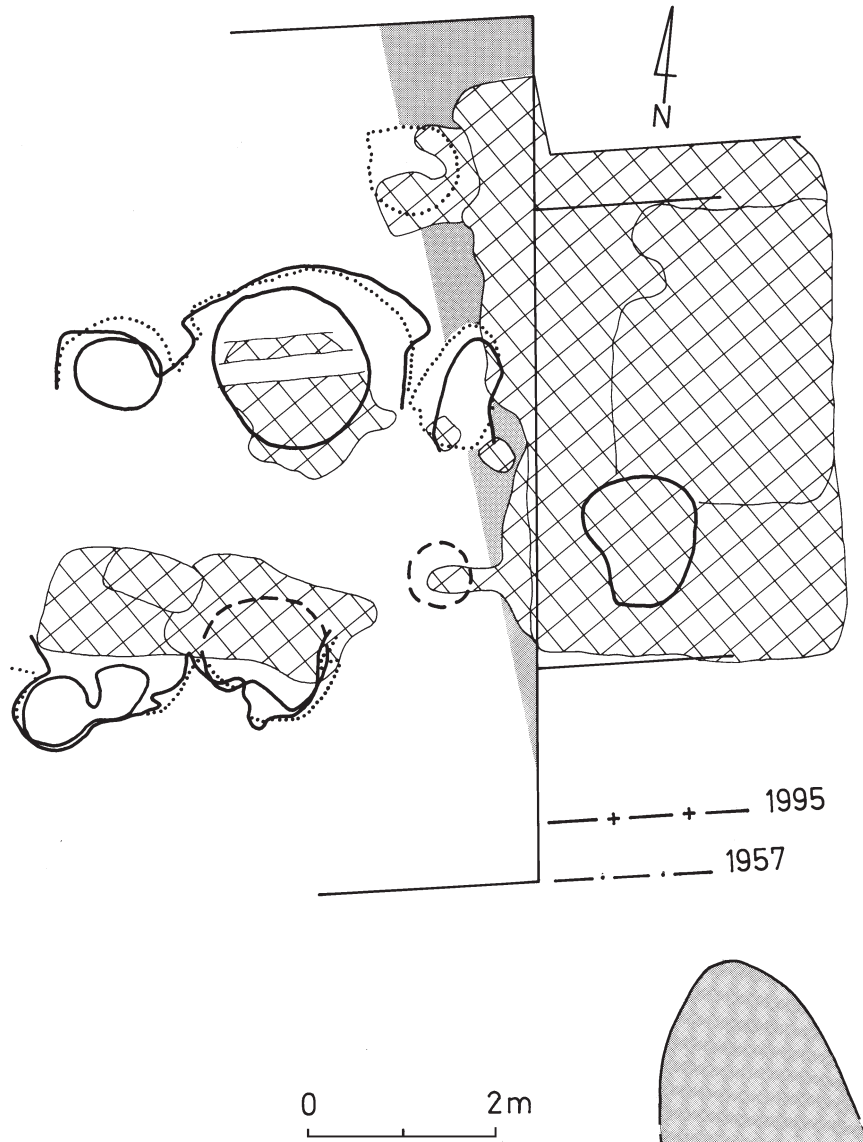

Fig. 13. Combination of soil traces and field boundary recorded in 1995, and of soil traces and field boundary recorded in 1957 (see also fig. 14). In the large rectangular disturbance the remains of the extraction/ foundation pit of the eastern endstone of the destroyed megalithic tomb, found 1995, have been indicated (drawing J.H. Zwier).

these traces in 1957 or did not record them is not clear.

3.4. The combination of the ground plans of 1957 and 1995

With the discovery of the extraction pit/foundation pit on the eastern end stone the ground plan O2 can be completed. Figure 14 shows the results of the 1957 and 1995 excavations combined. The locations of the foundation pit of D7 (south), of the extraction pit of D1 (south) as can be seen in the photos, and of the pit

with stones and the concentrations of field stones in the northwest corner of the excavation are also shown. The length of the floor was about 13 m and the width about 2 m. The *hunebed* had seven pairs of side stones and was orientated east-west. It is noticeable that the extraction pits on the north side are in a line but that on the south side the extraction pits for D3 and D6 lie outside the line indicated by the extraction pits of D2, D4 and D5, and the foundation pits of D3 and D7 as visible on the photos. The positions of the foundation pit of D6 (south) is given in broken line. The entrance to the chamber will have been in the middle of the south side,

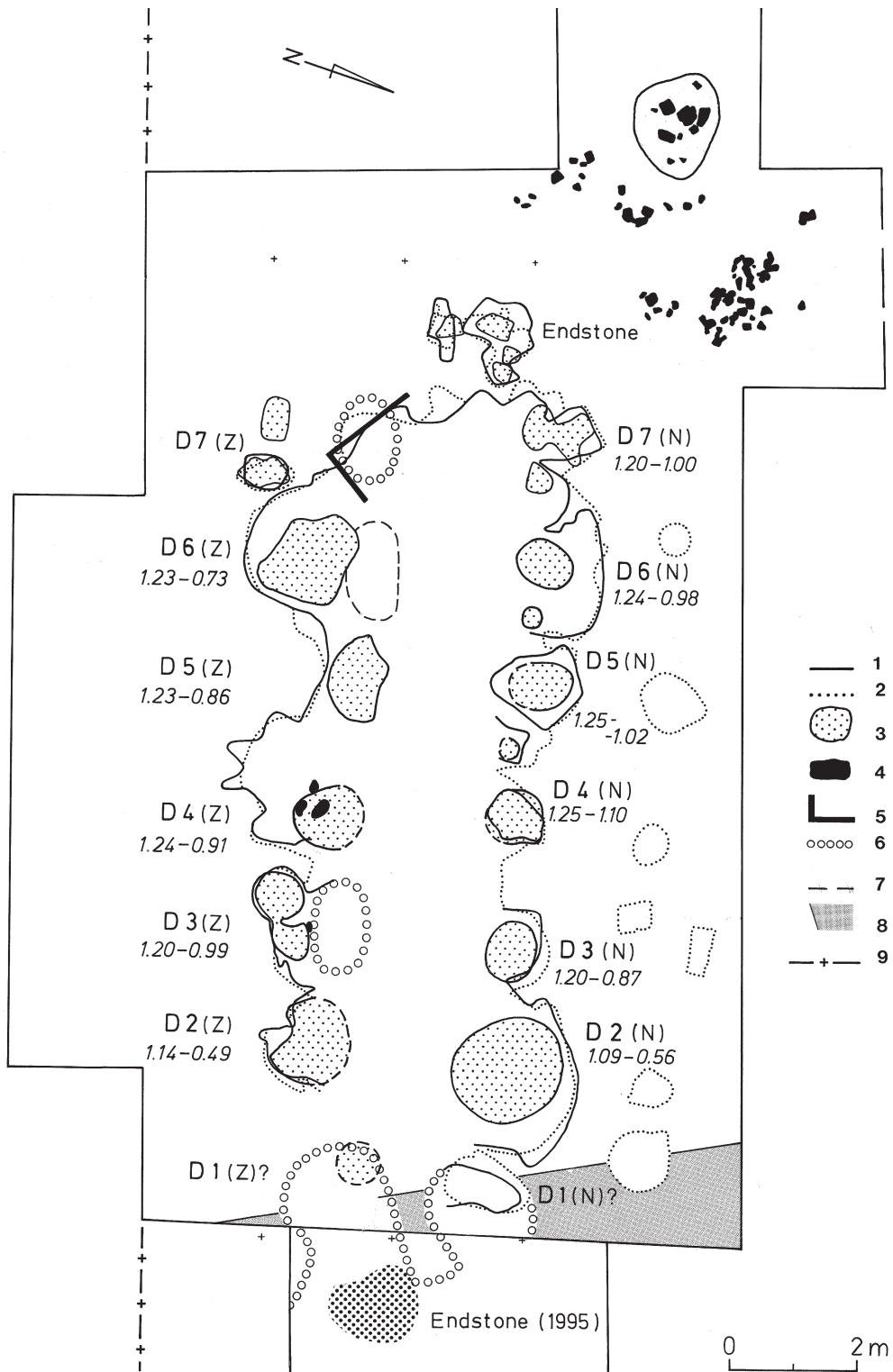

Fig. 14. Plan of the destroyed megalithic tomb O2, based on field drawings and photos of 1957. The place of the extraction/ foundation pit of the eastern endstone, found in 1995, has been indicated as well. Legend: 1. Outline of chamber area and pit outside chamber at level 1; 2. Outline of chamber area and pits outside chamber at level 2; 3. Extraction pits at level 3; 4. Field stones; 5. Situation of section through pit with stones of figure 9; 6. Locations of foundation/ extraction pits visible on photos; 7. Most likely place of foundation pit of D6 (z); 8. Cart tracks; 9. Field boundary (drawing J.H. Zwier).

between D3 and D4 or D4 and D5. No evidence, in the form of a sill stone or portal stones, was found which would support one or other location. A *hunebed* of this length would certainly have had portal stones but these have left no extraction pits behind.

The edge of the former mound should be looked for about 3 metres outside the side stones. The photos of 1957 suggest that this was indeed the case, on the south side in the extension of the excavation in Mensen's land. In the other parts of the 1957 excavation the iron pan is not easy to see. In 1995 a faint boundary between light yellow sand and a more brownish sand was recorded along the south, east and north side. This boundary is certainly somewhat further out than expected and in particular lies a metre further out on the south side the edge than in 1957. This is probably the result of deep ploughing of the area since 1957 and because the *hunebed* lies on a small ridge. The cutting off of the top of the ridge through excavation and deeper ploughing has led to the shifting outwards of the surfacing iron pan layer. The stones which Hijzeler discovered in 1957 in the northwest corner of his excavation lay approximately at the edge of the former mound and it is in our opinion possible that these stones had something to do with a stone kerb but we agree with Hijzeler (letter of 29-1-1973, cited by Bakker) that the seven pits north of the site of the burial chamber have no connection with a stone kerb.

We can estimate how much subsoil has been ploughed away from the site of the burial chamber since 1957. Feature S025 of the 1995 excavation corresponds with extraction pit D2 (south) of 1957. Assuming that Hijzeler sectioned this feature not deeper than 5 cm below its deepest point, the zero point of the 1957 levelling system can be calculated as c. 41.36 m +NAP. For S011/D2 (north) and S007/ 'the most easterly pit from the line of pits north of the *hunebed*' the same assumptions result in 41.43 and 41.42 m +NAP respectively. We assume therefore the 1957 zero point to be at 41.40 m +NAP. In 1957 the undisturbed subsoil outside the *hunebed* was reached at c. 1.20 m +, that is, about 42.60 m +NAP. In 1995 levels of c. 42.20 m +NAP were recorded immediately under the plough soil. Therefore since 1957 about 40 cm of subsoil has disappeared from the site of the *hunebed*, and this explains the absence of the remains of the shallower features found in 1957. Part of this is of course the result of the excavation itself. The third level of the 1957 excavation was a good bit deeper than the first level, at least in the area of the burial chamber. In the absence of levels on the field plans it is difficult to estimate how great the difference in height

was, but it may have been as much as 30–35 cm. The excavation trench was not deepened along its edges as far as can be seen from the photos. Furthermore, a change in ploughing after 1957 also played a significant role, namely the change from horse to tractor. In 1995 the plough soil appeared to be 40–45 cm thick and in places even thicker. The 1957 photos show a much thinner plough soil with an estimated thickness of 15–20 cm along the edges of the trench and possibly thinner in the area of the cobbled floor of the destroyed burial chamber. In 1957, the surface of the field above the stone-rich area lay 42.70 to 42.75 m +NAP. In 1995 the surface at the same spot was found to be at 42.60 to 42.65 m +NAP. Therefore a certain amount of levelling has taken place since 1957 but not much.

Another problem which was solved by the 1995 excavation is the identity of the 'trench' or 'ditch' on the east side of the former *hunebed*. This was apparently a 2.5 m wide, deeply cut system of wheel tracks which indeed in 1995 were not visible in the area of previous excavation due to the fact that about 40 cm of soil had disappeared, but which was visible in the adjacent and previously not excavated area (fig. 13). Apparently these wheel tracks ran north-south and penetrated less deeply in the area of the *hunebed*, possibly because the mound was still present when the wheel tracks were being formed. In 1995 the tracks reached a depth of 0.8 m below the present field surface in the field belonging to Mensen. But it should be pointed out that the fill of the wheel tracks immediately under the plough soil was made up of pure clean sand which gave the impression that they had been deliberately filled in, perhaps with sand from the former mound (fig. 15). As the extraction pits D1 (north) and D1 (south) and the eastern end stone lay in part or wholly under the wheel tracks these must have been made after the destruction of the burial chamber. Another set of deeply cut tracks was discovered west of the former *hunebed* running about the same direction. This track lay further away from the chamber, about 8 m west of the western end stone (fig. 12).

The tracks on the eastern side ran parallel to a ditch which at this level was 1.5 m wide and was undoubtedly the western boundary of the fields shown on the *Hottingerkaart* of c. 1790 and which is also recognizable on the cadastral map that Hijzeler (1966) reproduced (fig. 2b). At right angles to this ditch, another small ditch was discovered running eastwards, parallel to the present boundary division, but a metre north of it and therefore on Booijnk's property. This is undoubtedly the original land division which in the course of the time has gradually moved southwards.

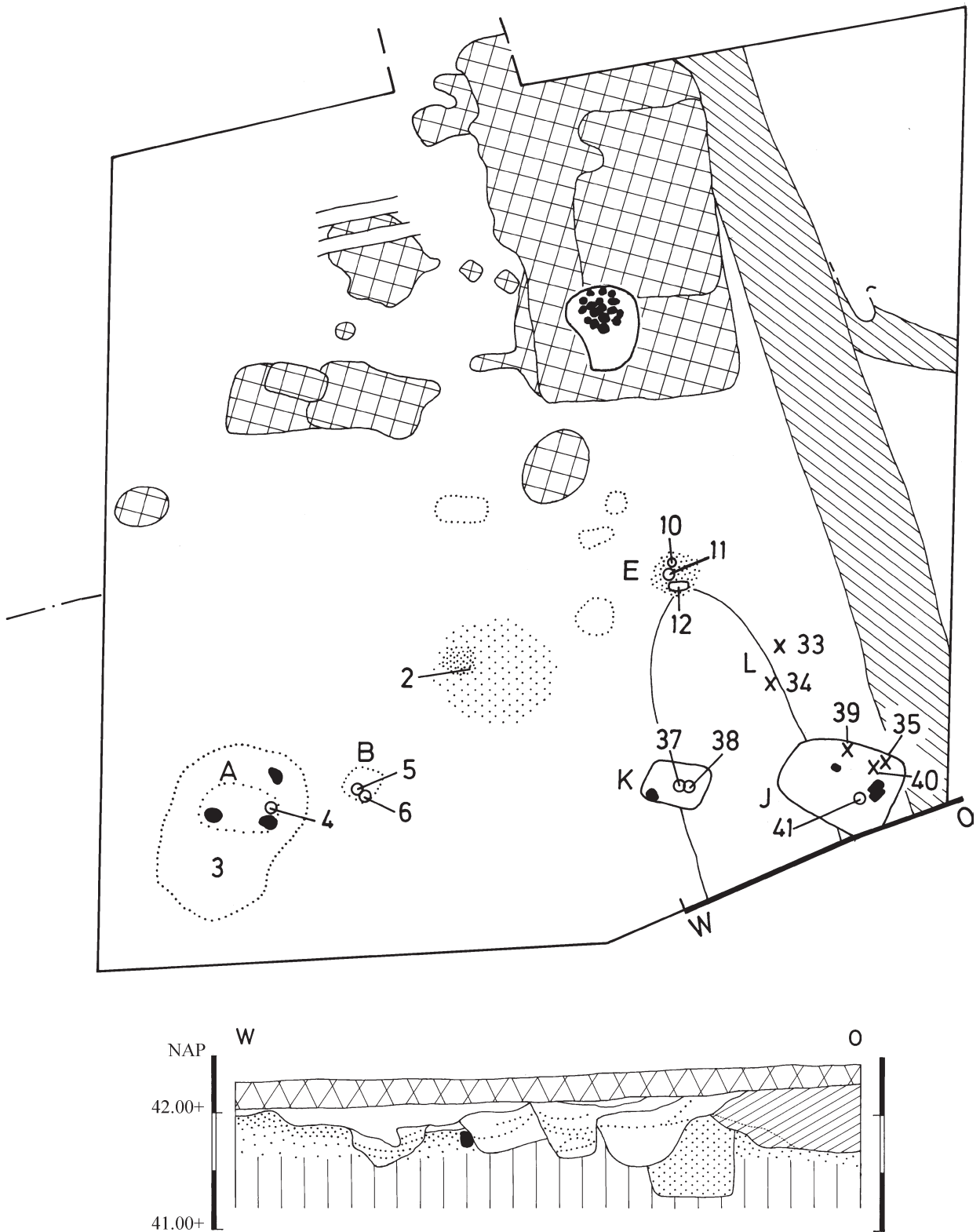

Fig. 15. Detail of the 1995 excavation trench and section of the cart tracks (drawing K. Greving/J.H. Zwier).

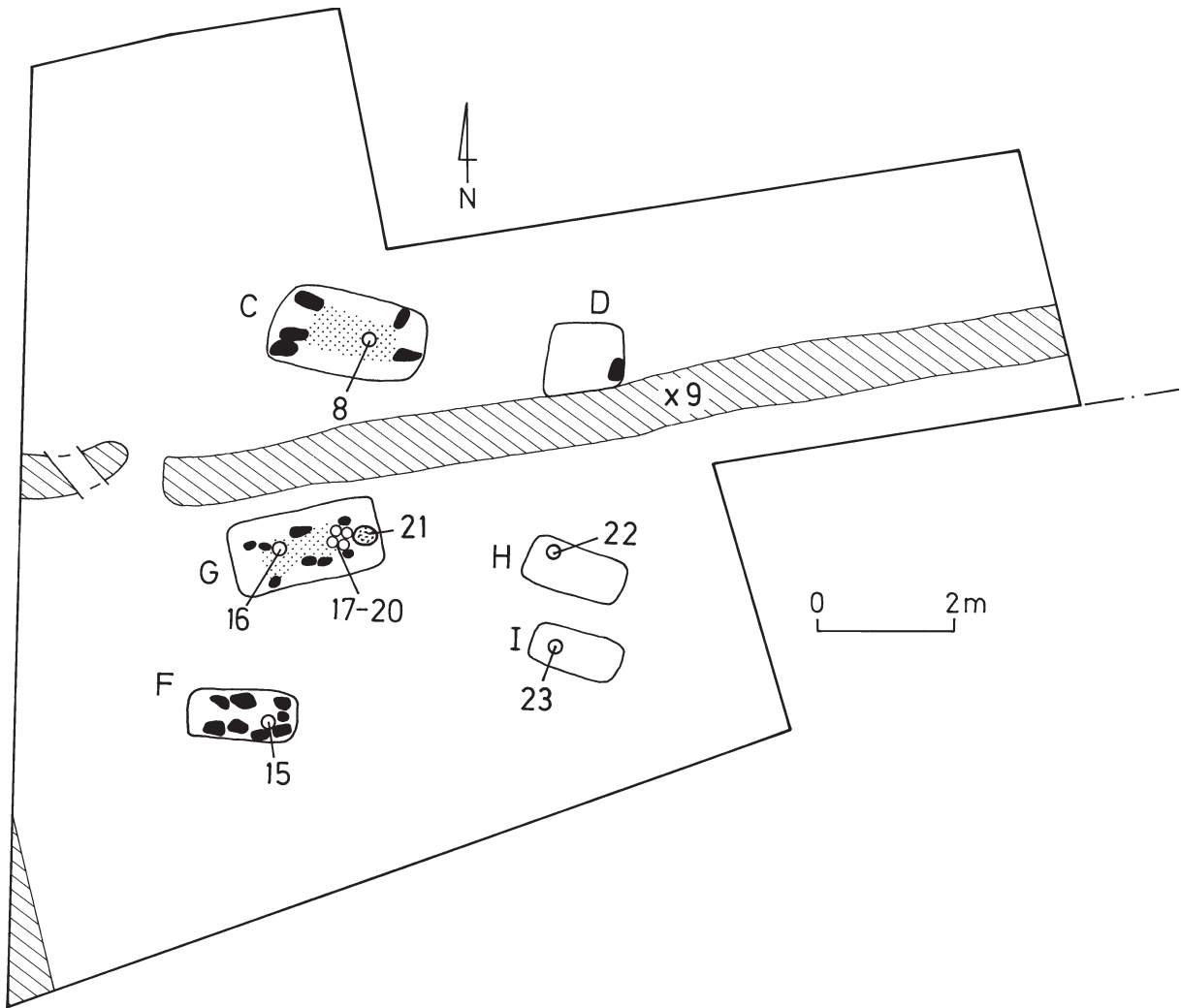

Fig. 16. Detail of the 1995 excavation trench (drawing K. Greving/J.H. Zwier).

In the fill of the east-west running ditch four sherds of red fabric with lead glaze were found (find no. 9: see fig.16). These belong probably to a dish with small feet, glazed on the inside and under the rim on the outside, of the type that Van Gangelen & Helfrich (1992: afb. X-6) date to the second half of the 17th century, but which was probably already in use before. According to the finds record in Amersfoort the sherds were identified by S. Ostkamp as 16th century ware.

3.5. The finds from hunebed O2

Large quantities of finds were discovered during the 1957 excavation, thanks to the fact that the soil from the destroyed burial chamber was sorted by hand. The finds were then stored in small cylindrical cardboard

boxes of the type used by chemists, on the lid of which notes were written in pencil about the location of the finds in the excavation. Unfortunately, it later appeared that some of these boxes had been used previously at the excavation of the *Federmesser* site of Usselo and that the previous and no longer relevant notes had not been cancelled or erased. A small number of finds were exhibited in the Rijksmuseum Twente. In February 1978 the construction of a new wing to the Rijksmuseum Twente was started. During the night of 21–22 March a waterpipe burst on the edge of the building trench. As result, not only the building trench but also the boiler room and the store room housing the prehistoric collection were flooded (to a depth of 80–100 cm). Part of the documentation, inventories and registration material were soaked, together with part of the correspondence archive, photographic collection and negatives. Part of

the archaeological collection disappeared under water, as well. Luckily it was possible to remove and treat this material the same day. About fifty vessels fell apart as a result of this (*Jaarverslag OKT over 1978: pp. 2 and 3*). The boxes of finds from Mander were also saturated. The wet boxes were packed into wooden cases, but because the boxes had been made using a water solvent glue, as they dried out they started to stick together and furthermore, they became mouldy.

In 1984 the wooden cases with the boxes were sent to Groningen. An attempt was made to separate the boxes but this was only partly successful. In many cases, the labels remained stuck to the bottom of the boxes which had been placed on top. All 334 boxes were given a consecutive number. The material was then removed from the boxes and cleaned and numbered, with the inventory number of the Oudheidkamer Twente for the finds from O2 (1112) and the number of the box, eg. 1112/1 to 1112/334 inclusive. In July 1985 the finds and the numbered boxes were passed to Dr J.A. Bakker of the IPP in Amsterdam and the material used over a period of two years for student practicals. The flint material was studied by H. Peeters who also wrote a report on it. The pottery was partially sorted; the decorated and undecorated sherds were separated and an attempt was made to identify individual decorated pots. The notes on the boxes were recorded also. In so far as these related to the *hunebed*, they produced some additional information. First of all, a small number of dates on the boxes showed that the excavation had taken place between 13th September and 4th October 1957. The excavation must have started before this, possibly on the 9th September (13th September was a Friday). The excavation must also have lasted longer beyond the second date because the finds with this date are from level 2. But the excavation cannot have lasted much longer than another week (4th October was also a Friday). It is also clear that an attempt was made to collect the finds by square, or by feature. The squares had a length of 2 metres and were as wide as the burial chamber, to judge from the notes such as '12–14 new level', 'square 4–6, base of chamber' etc. The collection by feature appears from notes such as 'DII', 'DIV North', 'side stone II', etc. It should be noted that the extraction pits on the field drawing have Arabic numbers instead of Roman ones and that no difference is made between north and south. Whether a lot of information was lost because of the flood is questionable. Many boxes appear to have had little or no information about the find spot. Furthermore, it is doubtful whether the collection of finds in such large squares is really useful, if the original distribution is to be reconstructed. The chamber area would have been divided into only

six squares. As previously said, the find spots of four axes are recorded on the ground plan.

In the spring of 1989 the more-or-less pre-sorted material was once more sent to Groningen. In the summers of 1989, 1990 and 1991 Adrie Ufkes used the lecture room of Poststraat 6 to lay out the decorated sherds, for sorting and to describe them. It soon became clear that the sorting of the pottery by teams of students had not been very successful and that a large number of the groups of sherds considered as unique pots had to be broken up. This is not surprising. The experience in Groningen has shown that the sorting of *hunebed* inventories is only successful if the entire assemblage can be seen. After the excavation of 1995 the flint material from O2 and from the flat graves was lent to Annelou van Gijn for use-wear analysis (see Van Gijn, 2002). The authors have not been able to examine this material so far. Ufkes (1992; 1993) was able to identify from the decorated sherds eventually 267 pails, bowls and dishes, tureens, and amphorae, of which 229 could be placed in one of Brindley's Horizons (1986). The funnel beakers sherds were not sorted nor were sherds of collared flask. It is clear that more than 60 funnel beakers were present. The undecorated pottery was not examined. On the basis of the study of the material in Amsterdam it appears that none of the undecorated pottery belongs to Horizon 7 (Late Havelte). Of the pottery which can be assigned to a horizon according to Ufkes, 36 pots belong to Horizon 3, 125 to Horizon 4 and 66 examples have characteristic of both horizons. Finally, two pots belong to Brindley's Horizon 5. This suggests that the use of the burial chamber dates to c. 3300 and 3000 BC (Brindley, 1986).

For an account of the flint and pieces of natural flint one can refer to Peeters (1986). According to this report based on the material studied in Amsterdam in 1985/86, 149 transverse arrowheads and three partly finished arrowheads were present. It is known that a further five arrowheads remained behind in the exhibition in Enschede. In total therefore 157 transverse arrowheads were found. Peeters also recognised thirty strike-a-lights, thirteen complete picks and three fragmentary examples (flint artefacts with an irregular triangular cross section and pointed end without traces of wear. In other publications these are usually described as strike-a-lights or *bikkels* one borer, eight scrapers, five flint knives of which four have wear polish along the working edge (sickle blades), one truncated blade, five unretouched blades/flakes, three small *beitels* (what these are is not clear from the description), eighteen worked pieces and eleven fragments of polished flint axes. These last derive, according to Peeters, possibly from five different axes.

On the basis of the polish, one fragment had been used as a sickle blade (this piece is not included in the list of blades with polish) and another fragment has been re-worked to a small axe with a length of 5.7 cm. The remainder of the flint material is made up of a large number of unretouched flakes, about fifty cores and many unworked pieces with natural surfaces. The use wear analysis of the flint tools/artefacts revealed little surprising results. In fact, an unusually number of tools showed no traces of use whatsoever (Van Gijn, 2002).

According to the *Jaarverslag OKT 1957* (p.3) five axes were found, but that is a mistake. In the OKT only four axes were registered, undoubtedly the axe 'of crystalline stone' and the three flint axes that were discovered during the excavation of the burial chamber and recorded on the field drawings (Nos 532–535). The 'crystalline' stone turns out to be quartzite. Furthermore, a small disc-shaped amber bead, a small flat stone with a perforation, a hammer stone, two fragments of a burnt skull and a small piece of cremated bone were found. In the notes made by Bakker of the practicals in Amsterdam a small sherd of red-baked pottery with greenish-yellow glaze is mentioned. Ufkes mentions in her thesis a *Pressblechfibel*, a lead point covered with sheet bronze (possibly part of a spur), and a flat piece of iron measuring 7×1 cm. It is not impossible that these finds do not come from the *hunebed* but from the 1964 excavation of the early medieval settlement of Hezingen (see AN 1964, *329–330), which by mistake became mixed up with the finds from Mander after the flooding of 1978 because they had been kept in similar chemist boxes.

Unfortunately, it is not possible to present either drawings or photographs of the finds from 1957. In Groningen, man power is not available and an attempt by the Oudheidkamer Twente to get money for a freelance draughtsman was unsuccessful (Verlinde, 1995/1996: p. 24).

4. THE ADJACENT FLAT GRAVE CEMETERY

4.1. The excavation

As has already been stated in the introduction, the excavation of 1995 took an unexpected turn when the owner of the property bordering the south side of the site, G. Mensen of Mander, informed us that excavation had also taken place on his land in 1957 and when a decision was taken by the directors of the excavation to extend the trench already opened in Booijnck's property, in an easterly direction in order to get a better in-

sight into the sub-recent features on the east side of the *hunebed* (see fig. 12). An analysis of the photographs from 1957 makes clear that the report of an excavation on Mensen's property is indeed true. But it is also clear that Hijzeler had in fact not done more than remove the plough soil from an area of 8×3.5 m to get an impression of the surfacing iron pan layer. Features and finds were apparently not discovered. Initially in 1995 it was planned to dig by machine two bucket-wide trenches at right angles to the long trench on Booijnck's land in order to document the iron pan once more. These trenches were 8×2 m (western trench) and 9.5×2 m (eastern trench). The first two metres were on Booijnck's property. Several features were uncovered in these trenches which had not been dug out previously and therefore had not been examined in 1957. For this reason, it was decided to clean a larger area between the two trenches. This resulted in an open area of 13×5.5 to 7 m (fig. 12).

Feature A

During the cleaning down of the opened area TRB sherds (find no. 3) were found in the subsoil in an oval area 3×2 m (fig. 15). As this area was deepened, the sherds continued to appear, although the area itself gradually became smaller. Almost 40 cm below the excavation surface the rim on a complete decorated TRB bowl (find no. 4) appeared. With the help of the digger, the soil in the neighbourhood was carefully lowered to the same depth. With some difficulty a small pit could be seen at this level but more because of the absence of infiltration than because of soil colour differences. The bowl stood on the base of the pit about 50 cm under the excavation surface and about 80 cm beneath the present field surface. It is clear that the small sherds were scattered in the fill of the pit which had been dug for the decorated vessel. This pit must have been approximately bowl-shaped. The sherds therefore pre-date the bowl and apparently belong to a much larger group of pottery fragments which lay originally outside the entrance to the *hunebed* near the foot of the mound, of which only those in the filling of the pit have been preserved. The rest has been ploughed away.

Feature B

After a phone conversation with Verlinde who was in Amersfoort at this time, it was decided to deepen the entire trench in Mensen's property so that any other deposits in unrecognized pits would not escape attention. This was done with the help of the machine whose driver was able to remove the soil in very thin layers.

About 1.5 m east of the first pit two undecorated TRB bowls (find Nos 5 and 6) were found standing beside each other, again in an ill-defined small pit, which was about 35 cm below the surface of the cutting and 65 m under the surface of the field (fig. 15). A number of other faint traces in this cutting turned out to have no finds and may have been of natural origin. Several of these included TRB sherds (find Nos 1, 2 and 5). The latter sherds are mentioned in the Amersfoort finds list as belonging to Feature B, but it is more likely that these were collected during cleaning).

Feature C

The next surprise came when the trench in Booijnck's property was extended towards the east in order to get a better impression of the recent and sub recent features east of the former *hunebed*, in particular the tracks and ditches (fig. 12). Between 9 and 14 m from the eastern end stone a flat grave and a possible but partly destroyed flat grave appeared (fig. 16). The flatgrave was roughly east-west in orientation (deviation 10° in direction WNW-ESE), subrectangular in shape and was recognized by its pale orange-coloured fill which was clearly distinguishable from the surrounding light yellow subsoil. The dimensions were 2.25×1.25 m. In three of the four corners was a stone and there were two in the fourth. These stones probably supported the coffin. A small decorated amphora (find no. 8) was discovered in the grave standing upright slightly to the east of its centre. The grave pit reached to 0.25 m under the surface of the cutting and 0.65 to 70 m under the present ground surface. Neither cremated bones nor a body silhouette were present. The dimensions of the pit were large enough for an extended adult inhumation and certainly for a crouched one.

Feature D

Several metres to the east of this grave an identical orange-coloured feature was discovered against the east-west running former boundary ditch, and partly cut away by it (fig. 16). Furthermore, in the orange stained ground was a stone. The orientation and dimensions cannot be given because part of the grave had been dug away. It was probably a roughly rectangular pit of about 1×1 m. Because neither cremated bones or a silhouette, nor pottery or flint was found it is not certain that this is a grave. However given the discovery of at least six flat graves in the adjacent area to the south (see below) and the flat grave west of it, it is likely to have been a partially dug-away grave. Any possible grave gift could have disappeared during the digging of

the ditch. The pit was large enough for the burial of a child, and reached to about 10 cm below the surface of the cutting and about 55 cm below the modern ground surface.

Following this, it was decided to extend the excavation on Mensen's land towards the east, to just beyond the possible flat grave on Booijnck's land which has just been described. Here, sub-recent features were documented such as the extension of the boundary ditch running in a NNW-SSE direction and the broad and deep cut track way which had already been described in paragraph 3.4. In addition a surprisingly large number of TRB features were uncovered (fig. 12). When it comes to attribution of finds to features, there are several small differences between the excavation diary of the first named author, the field drawings and the find list as it was later written up in Amersfoort. The excavation diary is here taken to be the more important source of information, followed by the field drawings. A corrected find list is added (see appendix).

Feature E

Where the northsouth running cart track ran out of the excavation pit (fig. 15), three pots were found together in sherds (find nos 10, 11, 12). According to the excavation diary, no pit was visible. The field drawing records a rectangular feature 0.6×0.6 m, probably the type of faint discolouration that is present in many places in an excavation but is only recognizable as an archaeological feature if a find is made within it. The base of this feature, or rather, the bottom of the pots lay c. 10 cm below the surface of the excavation trench, and an estimated 60 cm below the present day ground surface. The pots consisted of two decorated amphorae and a small undecorated bowl. It is not clear whether this is a small grave or a small pit with pottery similar to Features A and B.

According to the field plan, sherds of these pots were found in the fill of the track way south of Feature E. These sherds were given the find number 13 on the field plan. In the finds list which was made in Amersfoort, the find number 13 is described as "dispersed sherds, restored as an undecorated bowl (40% plaster)". This undecorated bowl in fact comes from the flat grave Feature G (to be described), and has on the field drawing the number 16. In the finds list, 16 is described as "several small TRB sherds and flint". It is therefore clear that after the excavation the find labels of the finds 13 and 16 were interchanged. It is extremely likely that the sherds which form a portion of the rim of an early Horizon 4 bowl (fig. 20) also

belong to the find number 13. These sherds have no number now. These are the only sherds which could have been described as TRB sherds, not the insignificant fragments which now have the number 16 (but should have number 13). The decorated rim sherd cannot be connected with the pots from Feature E, however.

Feature F

About seven metres east of Feature E a clearly definable grave pit was discovered, of which only the short west side was not fully recognizable because the traces were so shallow in relation to the planned surface (fig. 16). The grave pit was at least 1.7 m long and 0.75 m wide, and approximately east-west orientated. Along both long sides and the short east side lay fairly large stones (up to 35 cm in length), which probably supported a coffin. The grave pit reached about 7 cm under the level of the excavation surface and was an estimated 55–60 cm deep in relation to the modern ground surface. Within the stones on the east side of the grave pit stood a decorated amphora (find no. 15). The area between the stones was not wide and probably not long, so this may have been a child's grave.

Feature G

About 1.5 m to the north of this grave another clearly definable grave pit with stone supports was discovered (fig. 16). The pit had well-defined corners, was 2.20 m long and 1.5 m wide at the level at which it was planned and was orientated approximately east-west (with a deviation of 13° towards ENE-WSW). There were two rows of four large stones in the fill of the pit, along its sides. According to the excavation diary, there was a clear difference between the fill, with pale orange coloured sand outside the stones and grey sand inside the lines of stones. The stones and the colour of the sand indicate the former presence of a coffin, of which no other traces survive. The depth of this pit was not easily established because of the patchy grey sand in the subsoil, but it appears that in the central part the base was lower than it was along the edges. The pit reached a depth of about 20 cm below the planned level and 60–70 cm the present ground surface. Inside the line of stones at the eastern end of the grave pit four pots stood close together, two decorated amphorae, an undecorated amphora and an undecorated collared flask (find nos 17–20). During the machining of the excavation cutting, an undecorated bowl had already been discovered along the west side, which had stood somewhat higher up in the filling of the grave. This pot was no longer

complete. This pot was given the number 16 on the field drawing, but now bears the number 13. This is the bowl which was already mentioned in connection with Feature E as consisting of 40% plaster, which in the Amersfoort finds list is described as having been found in the cart track. It is clear however that the labels for the number 13 and 16 became mixed up after the excavation. No cremation or body silhouette was found this grave. Just above the base of the pit at the east end a grey area with small fragments of charcoal (find no. 21) was discovered, the purpose of which is not clear.

Feature H

Feature H was discovered two metres east of Feature G (fig. 16), and was a sharp rectangular pit with a pale orange fill with dimensions of 1.55×0.6 m, roughly aligned WNW-ESE (with a deviation of 18° from E-W). The pit reached a depth of about 10 cm below the planned surface and about 55–60 cm below the present ground surface. Near the northwest corner of the pit a decorated funnel beaker (find no. 22) was found. Although there were no traces of a corpse silhouette, this was undoubtedly an inhumation burial.

Feature I

Half a metre south of Feature H a sharply rectangular pit with light orange filling and dimension of 1.3×0.7 m was found (fig. 16). This had almost the same orientation as Feature H (deviation of 15° from E-W). The pit reached to about 15 cm below the level of the field plan, and c. 60–65 cm below the present ground surface. In the centre of the western half stood an undecorated bowl (find no. 28). This was also undoubtedly an inhumation grave, despite the absence of a corpse silhouette.

During the continuing lowering of the surface of the excavation in the vicinity of the cart tracks and the NNW-SSE boundary ditch two more graves were discovered.

Feature J

This feature lay along the southern edge of the excavation trench, between the cart tracks and the boundary ditch (fig. 15). It was a rectangular pit with a somewhat odd looking rounded-off NW corner, with dimensions of 2.0×1.35 m and an approximately WNW-ESE orientation. The southeast corner of the pit ran under the edge of the excavation trench, and was not investigated. The pit reached a depth of 50 cm under the level of the field plan and 105 cm below the present ground

surface. The fill was a uniformly grey colour and in the deeper parts fairly gritty. Although no trace of a cremation or an inhumation was discovered, it was certainly a grave. At the base lay three stones without any obvious function. Several grave gifts were found: a large decorated bowl standing upright near the middle of the south east side (find no. 41), a small tightly packed group of nine flint flakes in the east corner (find no. 40) (three of these flakes fit together and are from the top of a large thin-butted flint axe), a transverse arrow head at the centre of the long north east side (find no. 39) and a complete thin-butted thick-bladed flint axe which was found some 40–45 cm above the base of the grave pit, in the east corner of the pit and against its side (find no. 35). It appears that this axe was added to the grave gifts at the very last moment.

There is unfortunately some confusion because the field drawing notes stray sherds with the field number 36 from the fill of this pit. According to the inventory list drawn up in Amersfoort, these consisted of about 30 sherds of largely undecorated pottery, and pieces of stone and flint. Both authors excavated this grave and do not remember sherds in the filling of the grave. The diary also does not record this either. We assume that find number 36 in fact is made up of sherds that were discovered during the cleaning down of the area, as is also the case with the sherds of find number 24.

Feature K

This was discovered about 1 metre west of the previous flat grave, under the cart track (fig. 15). It was a rectangular pit of 1.0 m×0.7 m, approximately eastwest (deviation of 10° towards WNW-ESE) which reached a depth of 22 cm below the level at which it was planned and some 100 cm below the modern ground surface. High up in the fill a field stone was found in the south west corner, whose function is unknown. On about the long axis, slightly east of the centre, stood two undecorated pots beside each other (find nos 37 and 38). Despite the dimensions this seems to have been an inhumation grave. The grave pit was long enough for a young child or for an adult in a crouched position.

Feature L

During the cleaning down of the cart track two other finds of large fragments of pottery were made (fig. 15): a large body sherd of a pot with a sharp carination and half of an undecorated bowl, certainly TRB (finds nos 33 and 34). The diary records both pots, “during the cleaning down (of the cart tracks) pottery was found almost immediately, consisting of a pot lying on its side,

of which 2/3rds had already disappeared, probably as a result of the traffic along the track way. Immediately north of this a large sherd appeared, probably the last piece of a second pot. No trace of a pit was found”. This account suggests that at the time of discovery, the excavators assumed that the carinated body sherd and the fragmentary bowl were associated and that they had been discovered in the contact zone of the cart-wheel tracks. The remains of the small bowl could indeed be a grave gift but of a grave of which no trace remained. The sherd with the angled body cannot be categorically identified as a TRB sherd of this period. Given its manufacture and shape it could be a fragment of a much younger pot, which purely co-incidentally ended up in the same area as the TRB bowl. However, we should not be too dogmatic, but allow the possibility that the pot with the angled belly is a TRB product and we in fact do have here the very last traces of a small grave, or a pit with pottery such as Features A and B, with two pots.

To summarise then, the discoveries made on the south and southeast of the destroyed *hunebed* O2 are:

- I. A spread of pottery sherds approximately in front of the entrance, but well outside the foot of the mound. These sherds were preserved in the fill of a pit (Feature A), but it is possible that they are the remnants of a much more extensive spread which has been ploughed away;
- II. Seven pits which on the basis of shape, colour differences in the fill, and/or chocking stones at the base of the pit, and on the basis of the pottery (and in one case, flint objects) can be identified as flat graves (Features C, F, G, H, I, J and K);
- III. A partly dug away pit without finds which on the basis of the colour of the fill and the location is almost certainly a flat grave (Feature D);
- IV. Two scarcely visible pits, approximately in front of the entrance of the *hunebed* with complete TRB pottery, which appear to have been offering pits rather than flat graves (Features A and B);
- V. Two finds of TRB pottery below a shallow cart track without visible pit at the level at which the pottery was discovered. In these two cases, it was not possible to decide whether these are grave finds or pits with offerings of pottery (Features E and L).

Furthermore, it is not possible to exclude the possibility that the cart track or the sub-recent field boundary ditches destroyed other flat graves or pits for offerings. It is not known how far the flat grave cemetery extend-

ed outside the excavated area. Since 14–9–1999 a large area round the former *hunebed* has been placed under the protection of the Monuments Act. But it is clear that protection on paper is not enough. A number of the pottery finds were discovered very close to the base of the plough soil, and would in the coming years have been ploughed away if they had not been excavated in 1995. Several other graves were very deep and would in the short term have been quite safe. It is therefore important that the area is not ploughed more deeply than it has been up to now and that can only be achieved if the soil level is raised by additional soil brought in from elsewhere.

Several months after the excavation of 1995, an oval mound of 19×11 metres was placed over the former *hunebed* to a height of 1 m which approximated to the original size of the mound. The entrance to the chamber is indicated by a depression in the centre of the south side. The soil that was used for the mound became available as a result of the reconstruction of two fields known as the ‘Circles of Jannink’, west of the Getelo-Mander road, immediately south of the Dutch-German border (fig. 2a).

4.2. The finds from the features

The finds from Features A-K are described in this section. The few remaining finds either comprise stray sherds or stones and are not relevant to the dating of the site.

Feature A

About 250 sherds (find no. 3) were found in the filling of this feature; in fact, it is the distribution of the sherds which define the feature itself as no pit edge or cuts were visible. The pottery consists of sherds of various sizes and three handfuls of crumbs and fragments, derived from a large number of pots, at least thirty of which can be recognized either by distinctive sherds or reconstructed portions while another thirty appear to be represented amongst the featureless sherds. The following list is only of those vessels where a description is possible. The pottery is listed by Horizon and numbered as per illustration (fig. 17).

Horizon 2

Find no. 3-1. Open straight-sided dish on footring. *Tiefstich* and *tvaerstik*. Decoration in two undefined zones, the upper zone consisting of a band of broad vertical *Tiefstich* and the lower one of alternating defined panels of vertical broad *Tiefstich* lines and panels of horizontal *tvaerstik* lines. The undefined zonal layout indicate Horizon 2,

as does the relatively simple lower decoration.

Find no. 3-2. Open bowl, represented by three sherds only, two of an upper zone consisting of an undefined band of vertical *Tiefstich* similar to 3-1, and a body sherd showing inverted ‘V’ or ‘M’ motif.

Find no. 3-3. Pail. *Tiefstich*. Two undefined zones, the upper consisting of two widely spaced zigzag lines and the lower of vertical lines and strips of inverted ‘V’. Fragments of one lug show traces of a former perforation.

Horizon 3

Find no. 3-4. Thick-walled tureen with a wide shoulder represented by a group of sherds. One neck sherd only, with vertical *Tiefstich* lines. The shoulder sherds show a large zigzag or probably empty triangle pattern on the neck. There are indications of some form of decoration at the junction of the neck and shoulder.

Find no. 3-5. Thin-walled tureen with a tall, slightly conical neck. The shoulder is represented by several small fragments which suggest that it was comparatively short. *Tiefstich* and *tvaerstik*. Two *tvaerstik* lines under the rim, blocks of vertical *Tiefstich* and horizontal *Tiefstich* zigzags on the neck. There is a broad *Tiefstich* groove at the junction of neck and shoulder, and the few fragments of shoulder show filled triangles.

Horizon 4

Find no. 3-6. Bowl, fairly open with slightly curved sides and low, decorated lugs. *Tvaerstik*. At least four lines under the rim, a narrow band of horizontal zipper-like ornament, and in the lower zone at least some horizontal lines with vertical lines under the lugs. No sherds of the lower body.

Find no. 3-7. Bowl with low, decorated lug. The decoration is basically horizontal with *tvaerstik* lines under the rim and shorter lengths of lines making up some of the decoration. The uppermost lines include sections which are oblique.

Find no. 3-8. Bowl with horizontal lines of deep *tvaerstik* under the rim.

Find no. 3-9a and b. Bowl(s) represented by two sherds, each with *tvaerstik* lines and a horizontal band of incised chevron. Possibly but not certainly from the same pot.

Find nos 3-10a-d. Group of sherds of fairly similar paste and finish representing possibly four tureens, although the number of vessels is unclear. The relevant sherds are: two neck sherds of different pots with *tvaerstik* arranged as horizontal lines and blocks or shorter lengths of horizontal lines (one illustrated, a); two sherds from different pots from a plain area between the decorated neck and the shoulder decoration (one illustrated, b); one shoulder sherd and four joining sherds of a body, all from a tureen with a small shoulder with broad impressions and some vertical *tvaerstik* lines on the upper body (illustrated c and d); one sherd from the edge of junction of the shoulder and body showing traces of shoulder decoration similar to the previous mentioned shoulder but with at least one vertical line on the body; three further sherds from two tureen bodies which have

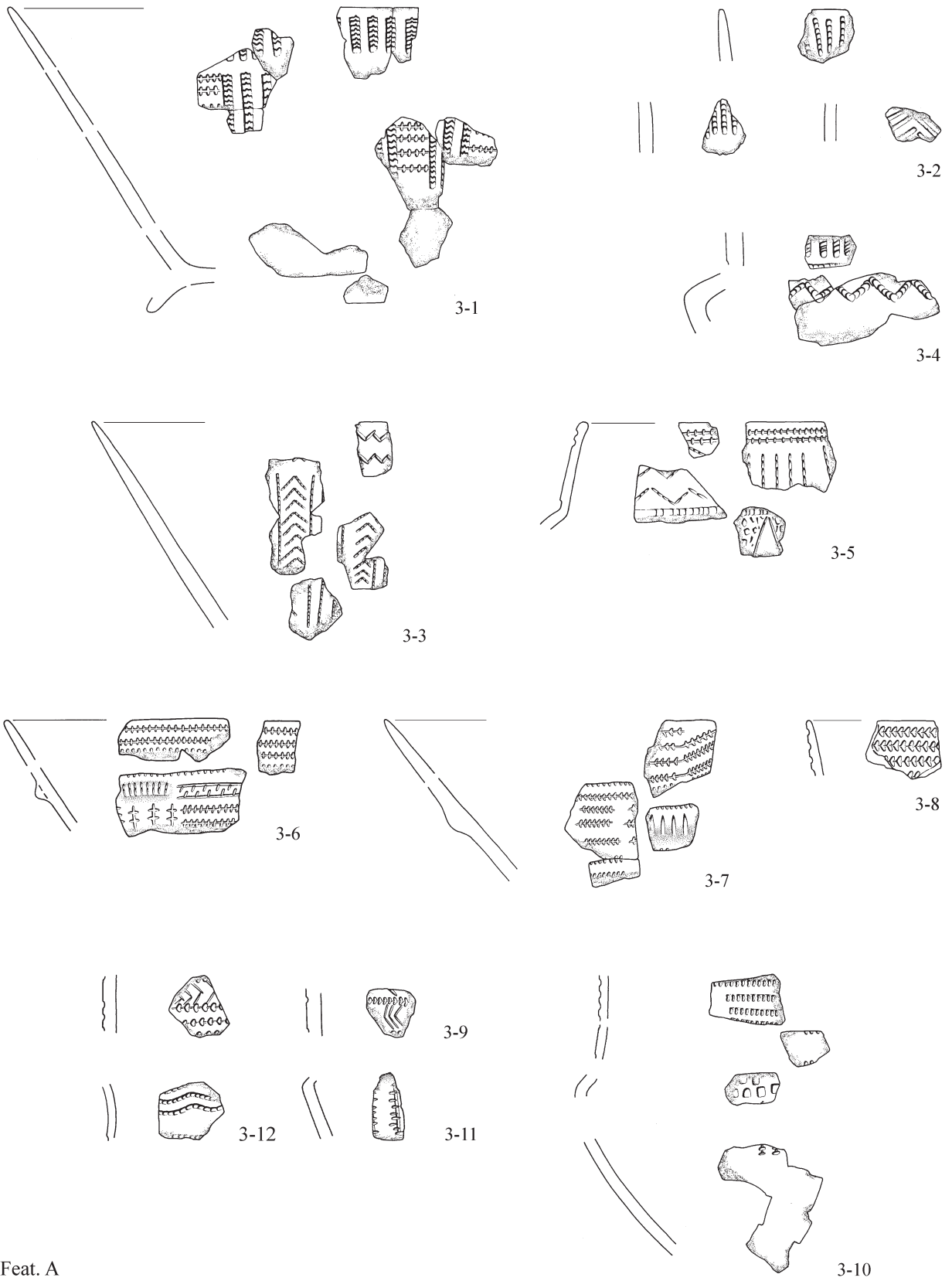

Feat. A

Fig. 17. TRB sherds from Feature A, scale 1:3 (drawing M.A. Los-Weijns).

some form of vertical decoration on the body, probably under the handle. There is a group of undecorated lower body sherds of similar fabric and finish.

Find no. 3-11. Tureen with irregularly executed *tvaerstik*, represented by a fragment of the rim and a sherd from the junction of shoulder and body showing at least two lines of vertical *tvaerstik* below the shoulder.

Bowl, two small sherds. Deep *tvaerstik* lines under the rim (not illustrated).

Tureen with *tvaerstik* decoration. At least three lines under the rim and groups of arches on the neck and the small lug. There is also one small piece from the body with vertical lines (not illustrated).

In addition to these vessels which can be approximately identified, there are sherds of two funnel beakers which cannot be placed in specific Horizons.

Find no. 3-12. Neck sherd from a funnel beaker with a widely flaring neck with at least three lines of *Tiefstich* zigzag lines on the middle of the neck and a horizontal *Tiefstich* lines at the base of the neck. Probably Horizon 3 or 4. Undecorated rim sherd of the upper part of a funnel beaker with a widely splaying mouth (not illustrated)

There are undecorated rim sherds of possibly twelve vessels, most probably either undecorated bowls or funnel beakers. Most are from poorly finished irregularly-shaped vessels. Four are likely to be funnel beakers. One vessel is represented by a number of featureless sherds (none illustrated). The remaining featured sherds are small. There are sherds of three separate bases, and several groups of featureless sherds are probably from the same pots (none illustrated).

In summary, the filling of Feature A includes sherds of a large number of pots, possibly as many as sixty, most represented by single or few sherds, from Horizons 2, 3 and 4. In addition to these, Feature A contained a complete pot:

Find no. 4 (fig. 18). Slightly globular bowl with extremely close-set *tvaerstik* impressions. Four lines under the rim, band of horizontal blocks of six lines terminating in two of short lengths of *tvaerstik*, with vertical blocks of eight lines below. The pot is smoothly finished, both inside and out. Although the slightly globular shape and the closely set impressions suggest Horizon 5, *tvaerstik* is not a common constituent of the Horizon 5 repertoire. Both the *tvaerstik* impressions and the type and quality of finish are very similar to the tureen-amphora find No. 17 from grave Feature G.

Feature B

This barely visible pit beside Feature A contained two complete pots (fig. 18):

Find no. 5. Bowl, damaged during discovery. Undecorated, the outer surface has been smoothed and the bowl appears to have been fairly symmetric.

Find no. 6. Small shallow bowl, probably a scoop. Irregularly shaped and finished.

Feature C

This flat grave was discovered unexpectedly by machine when digging a trench east of the *hunebed*. It contained one vessel (fig. 18).

Find no. 8. Tureen-amphora, chiefly *Tiefstich* decoration. Horizontal lines under the rim, horizontal blocks of eight and nine lines, the lowest two being of short horizontal stabs. There are very short vertical *tvaerstik* lines (two impressions) on the shoulder, similar to those occurring on the tureen-amphora find no. 18 and short vertical blocks on the upper body. This vessel has a raised foot ring and two horizontally pierced lugs on the surviving side and is fine-walled. Horizon 5.

Feature D

contained no finds.

Feature E

This feature was either an almost completely destroyed flat grave or a pit with pottery similar to Features A and B. Three pots were found close together, in fragments (fig. 18).

Find no. 10. Small, thin-walled but not highly finished bowl or scoop.

Find no. 11. Small tureen-amphora, similar to but with more slender proportions than find no. 8. It has a single small, unperforated horizontal lug with a block of inverted 'V' below on the body. The foot ring is very low and has been simply formed simply by pinching the edge of the base. *Tiefstich* ornament. Horizontal line under the rim. The neck is fully decorated with a broad band of four zigzag lines. The very slight shoulder is marked by a horizontal line and the body has groups of vertical *Tiefstich*. The vessel is thin-walled and regularly shaped but the surfaces are not as smooth as some of the other decorated pots and has a gritty texture. Horizon 5.

Find no. 12. Amphora type 2 with smoothly flowing junction between neck and well-rounded body, two opposing lugs and a small raised foot. *Tiefstich*. Three horizontal lines under the rim, the lowest consisting of short lengths of two stab *Tiefstich*, and horizontal blocks of five or six lines on the neck. There is no line marking the junction of neck and body and the vertical blocks of lines form a chequer pattern with the neck decoration. Below the lugs are vertical chevrons. The surfaces have not been well-smoothed and the pot has a roughish texture. The ornament is somewhat unevenly executed. Horizon 5.

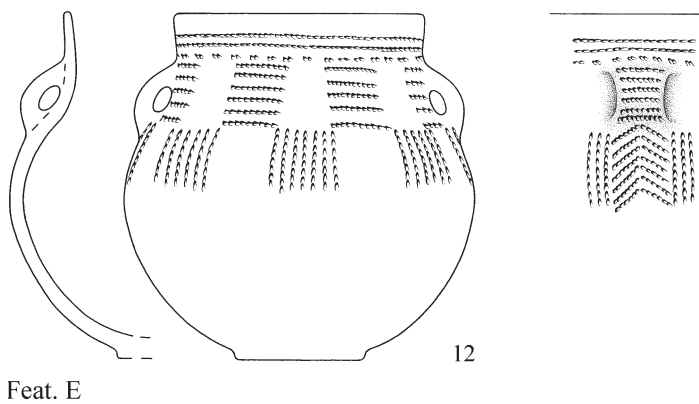
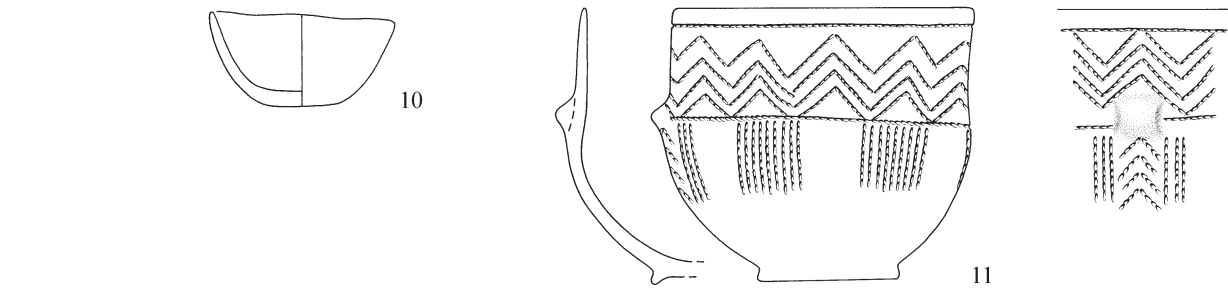
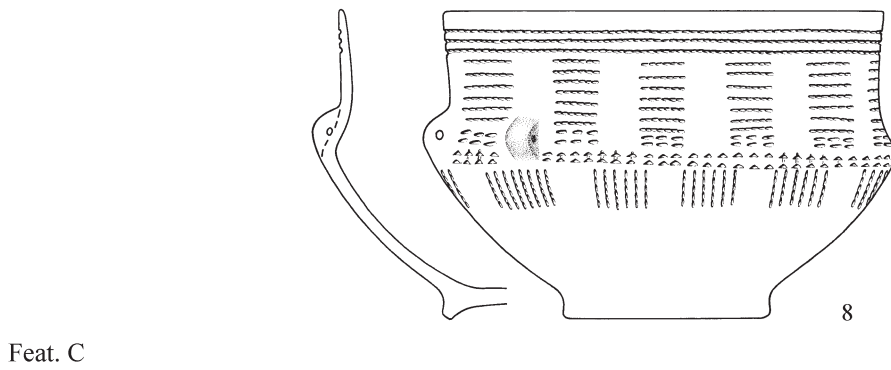
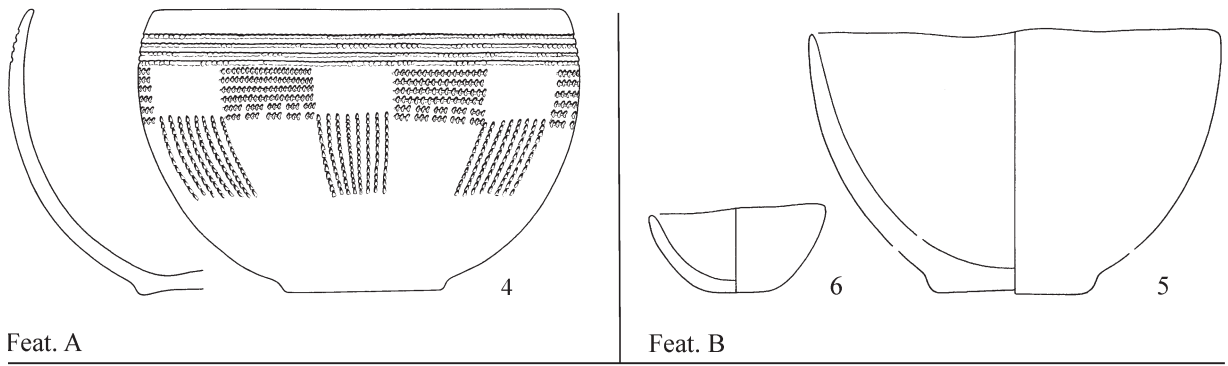

Fig. 18. TRB pots from Features A,B,C and E, scale 1:3 (drawing M.A. Los-Weijns).

Feature F

This flat grave with two rows of large stones contained one pot (fig. 19).

Find no. 15. Tureen-amphora with proportions similar to find nos 17 and 18. The vessel was damaged during discovery and about half the upper part is missing. Slightly conical neck and small shoulder with the remains of two small, perforated lugs on the damaged side and a small foot ring. Although the pot is thin-walled, it is not as carefully smoothed and finished as find nos 4 and 17 and the decoration is irregularly executed. The pot was smoothed after decoration and some of the impressions are partly closed as a result of smearing of the surface. The decoration is executed chiefly in *tvaerstik* but in places is practically indistinguishable from *Tiefstich*. The impressions vary widely even within the same piece of decoration and are not completely horizontal. The ornament consists basically of three lines under the rim, with vertical blocks of five to seven lines on the neck. On the shoulder there is a single line of vertical stabs and on the body are groups of vertical lines. These have from four to nine lines and vary in length. Horizon 5.

Feature G

This flat grave also contained stone supports for a coffin. Unfortunately, after excavation, the finds label of one of the finds was changed accidentally with the label of a handful of stray finds, but thanks to the excavation diary, the attribution to this grave is clear. This grave contained five vessels (fig. 19):

Find no. 16 (corrected). Slightly open, undecorated bowl on a small pedestal. Not well-shaped or finished. This bowl was damaged during discovery.

Find no. 17. Tureen-amphora with closely set, very regular *tvaerstik* ornament. Band of six lines under the rim and blocks of five, six (once only) or seven horizontal lines on the neck, the lowest two consisting of short lengths of line. The shoulder is marked by a line of horizontal chevrons. The body decoration consists of groups of lines, starting a short distance below the shoulder itself. The vessel is remarkable for having two lugs on the same side of the vessel, each with a pair of chevrons. The vessel has a very low footring. The use of *tvaerstik* and the chevrons on the shoulder are reminiscent of Horizon 4 and suggest an early stage in Horizon 5 for this vessel. The form of the *tvaerstik* impressions and the careful finish of the vessel are very similar to bowl find no. 4 and it is likely that both were made at the same time or by the same person.

Find no. 18. Small tureen-amphora with *tvaerstik* ornament. Four lines under the rim, band of blocks of five (one example), six, or seven horizontal lines on the neck. The shoulder is marked by short vertical lines of *tvaerstik* (two impressions only). The body has blocks of eight, nine (one only) or ten vertical lines. There are two small, undecorated, perforated lugs on one side of the vessel. As the vessel is complete, it is clear that no counterparts existed on the opposite side. The raised footring is neatly made. The vessel has a smooth

finish inside and out. Horizon 5, the *tvaerstik* ornament suggests an early stage.

Find no. 19. Undecorated shouldered flask, with a comparatively short neck, well-rounded body and two well-marked opposing lugs on the shoulder, not symmetrically placed. The lugs are on the shoulder rather than on the base of the neck, but otherwise the shape is similar to a type 2 amphora (see Brindley, 1986: fig. 1).

Find no. 20. Collared flask, undecorated. The flask is round-based, and has an asymmetric, spherical body. The well-marked but low collar occurs midway along the neck and has not been well-finished. The inside of the neck has been smoothed with a finger. The vessel cannot stand upright on a hard surface.

Feature H

This flat grave contained only one pot (fig. 20):

Find no. 22. Small funnel beaker with *Tiefstich* decoration. The neck is very slightly open and undecorated. At the base of the neck is a line of zigzag. The body has a short high shoulder, and is decorated with alternating vertical groups of long and short lines, the number of lines varying considerably. The vessel is not well smoothed and the ornament is irregularly executed. Funnel beakers are a constituent of Horizon 4 and fell out of use in early Horizon 5.

Feature I

This feature was another well-defined flat grave, containing only one pot (fig. 20):

Find no. 23. Bowl, undecorated. Damaged slightly during discovery. Well-smoothed on outside,

Feature J

This well-preserved flat grave contained one pot and several flint objects (fig. 21).

Find no. 35. Flint axe, trapezoidal in shape with lenticular/lentoid long section. The two faces are well-polished. The sides are largely flaked but several small patches of polished surfaces are present. An unusual feature is that the flaked areas all show a well-developed gloss, and remarkably, that this is below the level of the polished surfaces. The highly developed gloss on all the unpolished flaked parts is distinctive and unusual. Gloss develops under the haft due to friction but is confined to a band where the former haft was present. In this case, the gloss is distinctive because it occurs on almost all of the flaked surfaces, and occurs below the level of the polished surfaces. This indicates that the axe was originally larger with a broad haft under which gloss developed and it was subsequently remodelled chiefly by shortening its length at the blade end, and extensively polishing the main faces. In its present form, it shows no or signs of damage, use or re-sharpening. The flint is grey with a small amount of cortex.

Find no. 39. Small arrowhead made on a small flake. Grey flint, similar to the flint of axe find no. 35

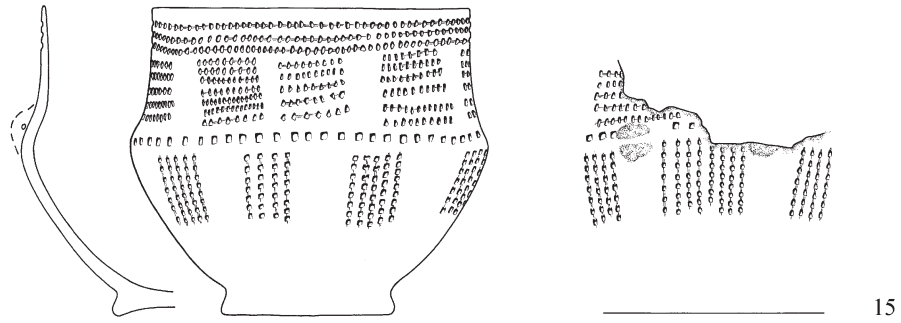

Feat. F

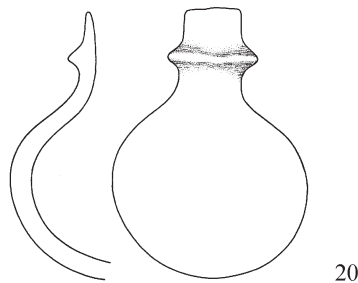
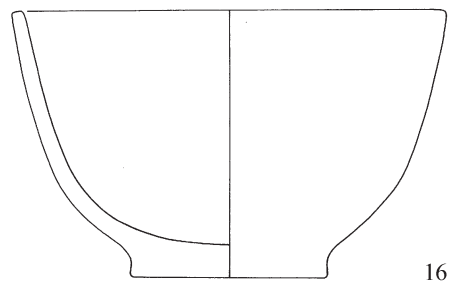
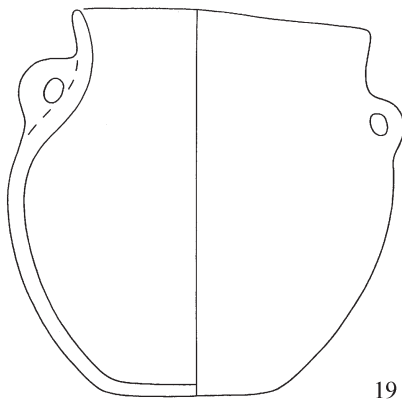
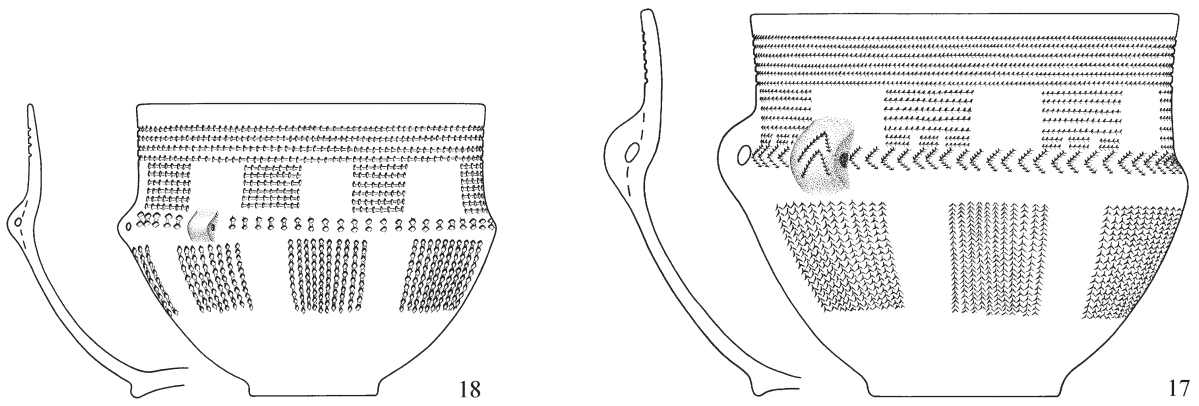

Feat. G

Fig. 19. TRB pots from Features F and G, scale 1:3 (drawing M.A. Los-Weijns).

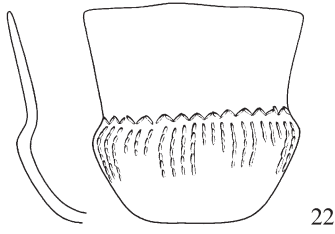

Feat. H

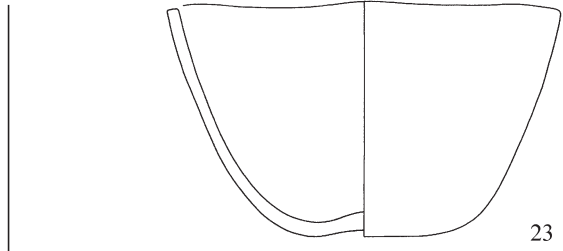

Feat. I

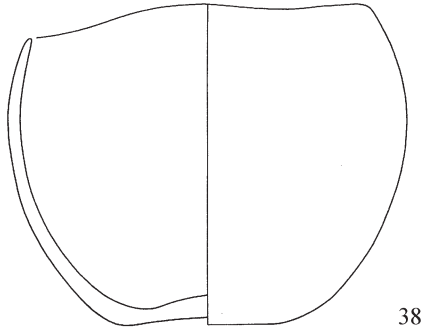

Feat. K

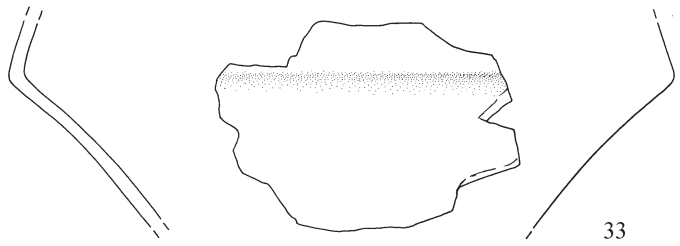
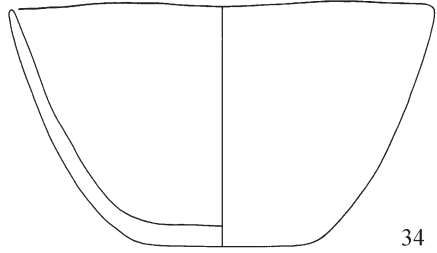
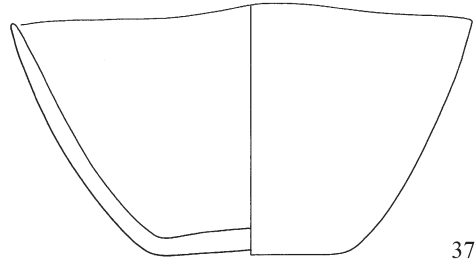

Feat. L

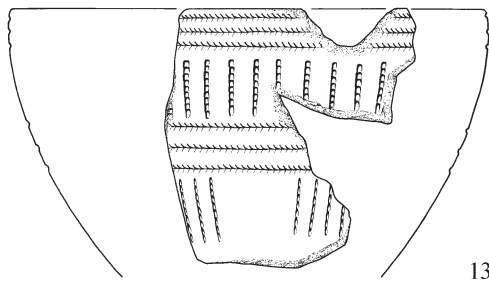

Find nr. 13

Fig. 20. TRB pots from Features H, I, K, L and find no. 13, scale 1:3 (drawing M.A. Los-Weijns).

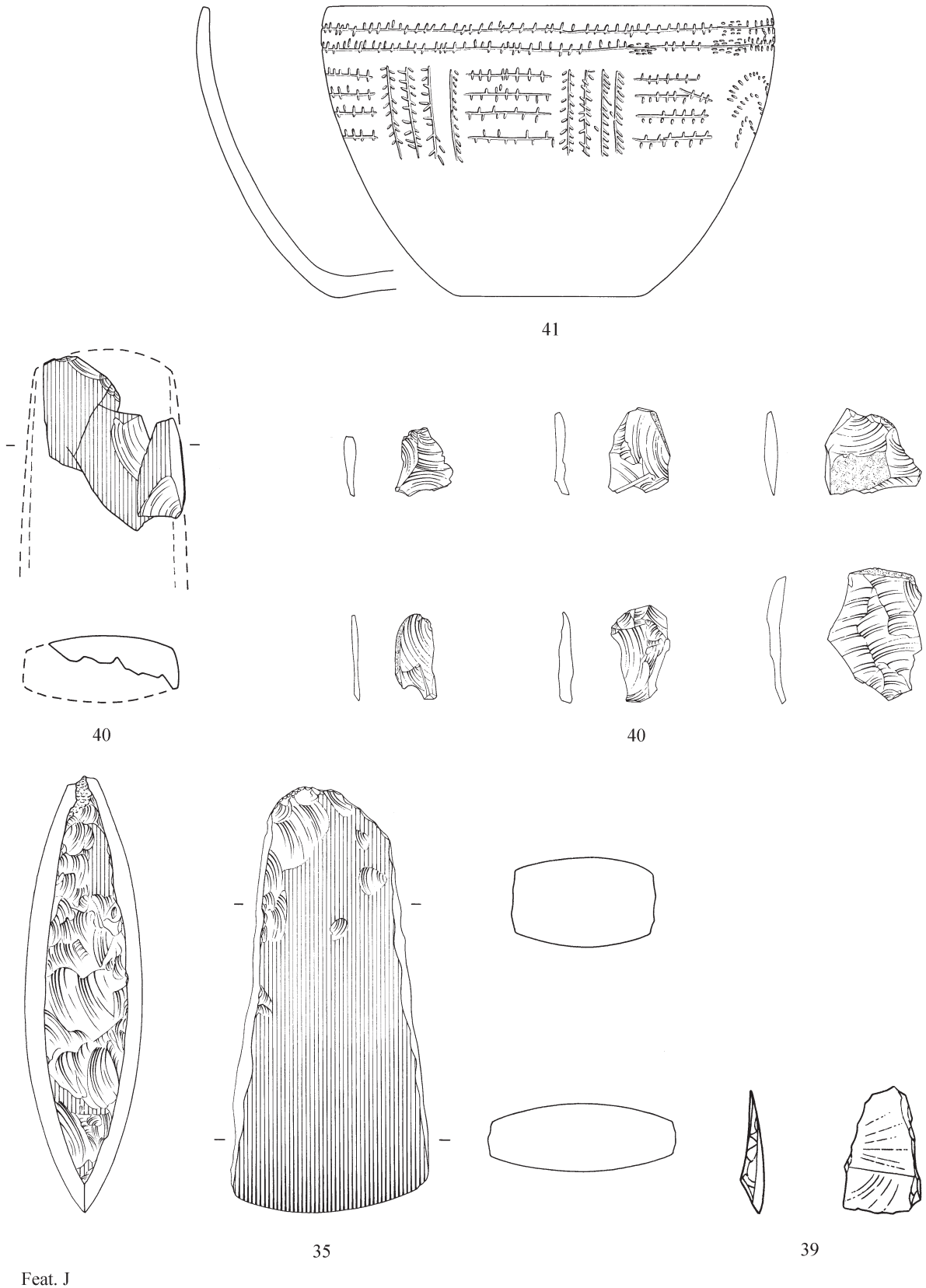

Feat. J

Fig. 21. TRB pot and flint artefacts from Feature J, scale: ceramic 1:3, flint 1:2, but flint arrowhead 39 1:1 (drawing M.A. Los-Weijns).

Find no. 40. Nine flint flakes found close together. Three of these flakes fit together and are part of the top of a polished flint axe with polished sides.

Find no. 41. Large, slightly open bowl. *Tvaerstik* decoration. The ornament is confined to the upper half of the vessel and consists of two horizontal lines and alternating blocks of four horizontal and four vertical lines with a single block of inverted 'U'. The *tvaerstik* is loosely and irregularly executed. Horizon 4, late.

Feature K

Despite its dimensions this feature must be a flat grave. It contained two pots (fig. 20).

Find no. 37. Bowl, undecorated, slightly open, asymmetrical and not well-finished.

Find no. 38. Bowl, slightly-closed mouth, undecorated, well-smoothed.

Feature L

This feature consists of fragments of two pots, found close together under the sub-recent track (fig. 20):

Find no. 33. Large sherd of a biconical vessel

Find no. 34. Undecorated bowl represented by about half the pot. The bowl is slightly open, and is neither well-shaped nor finished.

In addition to this material, sherds of a bowl with *Tiefstich* and *tvaerstik* ornament were found almost certainly south of Feature E, in the fill of the sub-recent track. Although unnumbered, these fragments belong to find no. 13 (fig. 20). The sherds (all joining) represent the continuous profile from rim to the junction with the base. The decoration is in two zones, the upper consisting of a band of broad, vertical *Tiefstich* lines between two bands of three horizontal *tvaerstik* lines. The lower zone consists of vertical groups of fine *Tiefstich* lines. Horizon 3/4.

4.3. Discussion

Although the general development of West Group TRB pottery is well-known by now, it is likely that more limited local typologies and styles remain to be documented. The richly decorated pottery, large numbers of different forms, the development of the different types and ornament coupled to two important aspects of this material, the very large quantities of pottery that occur on single sites and the occurrence of these over a large geographical area, suggest that it should be possible to trace some of these more local developments. Mander is situated in an area where few other finds of TRB pottery have been made. The closest large assemblage was excavated by Schlicht at Uelsen in 1955. This site lies

approximately four kilometres north of Mander. It is published in only a very summary fashion. The pottery from Mander O2 itself remains unpublished and unillustrated.

The pottery from the flat grave cemetery shows some interesting features. The occurrence of two lugs on one side only of several of the tureen-amphorae (find Nos 15, 17 and 18, also probably No. 8) is remarkable. As this feature can only be recognized from complete or near complete vessels it may be more widespread than now appears. The small foot rings and the use of a very tight form of *tvaerstik* may also be a regional preference. The earliest grave (on the basis of the pottery) is Feature J, which contained the Horizon 4 bowl, the flint axe, the arrowhead and the fragments of a second flint axe. This grave may well have been used while the chamber was still in use. The grave Feature H which contained a small funnel beaker may also be early in the sequence. The other graves with pottery may all have been used in a relatively short period, with burials taking place at short intervals. All the decorated pottery and probably the undecorated pottery as well are of the same style (shape, finish and decoration) and it is not possible to suggest the order in which they may have occurred.

The pottery from Feature A consists of two elements: the filling of the pit and the complete bowl. The filling of the pit contained pieces of some sixty vessels, many represented by single sherds. These stem from an extended period; pottery of Horizons 2, 3 and 4 are all present, but apparently no pottery of the same horizon as the complete pot. The origin of the sherd material is not clear. It was obviously in a fragmented state when it became incorporated in the pit fill. The mixture of styles points to it either coming from a midden where refuse was mixed or that it originated as broken material taken from the *hunebed* chamber which was within a couple of metres of the pit. This last appears the more likely as the older pottery did not appear to have suffered more damage than the younger pottery. However, Ufkes only recognized Horizon 3, Horizon 4 and a small amount of Horizon 5 pottery in the chamber. All the pottery in the filling of the pit is older than the intact bowl and with the exceptions of the bowl in Feature J and probably the funnel beaker in Feature H, pre-dates the pottery in the other graves.

The consistency of the pottery from the flat graves (late Horizon 4 but especially early Horizon 5 pottery) indicates a short period of activity. This seems to have occurred at the time that the final deposits were placed in the chamber and possibly for a brief period thereafter. Later, or indeed other, burials may exist outside

the limited extent of the excavation. Activity within the two centuries between 3100 and 3000 BC could encompass easily both the range of pottery styles and the amount of activity discovered. This bracket is based on the suggested dating of the typo-chronology of the TRB pottery sequence (Brindley, 1986).

5. MANDER IN ITS WIDER CONTEXT

Hunebed O2 of Mander was, as far as is known, the most southerly in the Netherlands, but even when we look across the border and take into account the distribution of megalithics in Germany, O2 remains in a fairly isolated position. The *hunebed* of Mander lies some 40 kilometres south of the nearest *hunebed* in Drenthe. The other *hunebed* in the province of Overijssel, O1 at De Eese, lies even further away. There are no other *hunebedden* in Twente. However, there are two curious references in the literature. According to Benthem (1920: p. 3) “the *hunebed* on the southern slope of the Vriezenberg near Rijssen, although badly damaged, was still recognisable in 1856”. This *hunebed* is not mentioned by any other writer, not even by Count F. Van Bijlandt (1839) who described in great detail his visit to the Vriezenberg and Herikerberg. Neither the Hottingermaps of c. 1790 (Versfelt, 2003), nor the military and topographical map of c. 1850 show any trace of this site. Because Benthem does not give any references, it must be assumed that the account is his own. He was born in 1844 in Markelo (Benthem, 1920: p. 503 foot note) and must have lived there until he went away to study and could therefore have seen the *hunebed* in his youth. The question is how much weight can be given to the memories of a twelve year old, recorded sixty-three years later when even professional archaeologists seem to be unable in some cases to distinguish the difference between a *hunebed* and a very large boulder split into pieces by natural forces (Huisman & Van der Sanden, 2003). Equally doubtful is the reference cited by Bakker (1988: p. 70) that De Clercq mentions a ‘*hunebed*’ between Wierden and Hoge Hexel in a diary of 1812–13. In fact, De Clercq saw a mound and was told that it was “a *hunebed* like those that are found in Drenthe”. Ter Kuile (1938: p. 7) was completely unconvinced that this was a *hunebed*. It was undoubtedly nothing more than a burial mound.

If we look across the border, it appears that O2 was not completely isolated. Bakker (1977/78: pp 23–24) has already made clear that Sprockhoff (1975: p. 106) misunderstood Picardts account of the number of *hunebedden* in the county of Bentheim (a few, instead of many), but *hunebedden* had certainly existed

there. Visch (1820: p. 17, footnote) described how in August 1819, together with other antiquarians, he had discovered “a *hunebed* (like the ones known in the province of Drenthe) between Ulzen and Getelo”. According to Schlicht (1956: p. 87) Picardt had already described this *hunebed* and did Visch only refer to a destroyed *hunebed* whose location he himself did not know, but this statement is based on nothing and must be a mistake. Furthermore, Visch (1820: pp. 128–129) mentions that in *Kerspel* Ulzen a number of *hunebedden* were destroyed for the building of houses and sheds. Schlicht discovered the remains of two destroyed *hunebedden* in April 1955 east of the Uelsen-Getelo road, 4 kilometres north-northeast of Mander O2 (for an account, see Schlicht, 1956). These also lie on the west slope of the ice-pushed ridge, but higher up, at about 60 m +NAP. It is interesting that the local toponym *Steenebarg* (dialect) or *Steinberge* (high German) had already been mentioned by Specht (1935) as evidence of a possible destroyed *hunebed*. (The occurrence of this toponym makes it very likely that just as in Drenthe (see Huiskes, 1985) *hunebedden* were known in Twente as *steenbergen* which can be important for field name research and when looking for information about lost *hunebedden* in the *markeboeken*).

The more southerly of Schlicht’s destroyed *hunebedden* was excavated in the same year. Although the ground plan was far from clear because of extensive destruction, it is very likely that a large burial chamber, possibly with eight pairs of side stones stood here formerly (Schlicht, 1957). Unfortunately, the artefacts from this site have not been published. According to Schlicht (1957: p. 21) about 100 pots could be recognized but she only illustrated a small selection of these. The illustrated material belongs to Horizons 3, 4, and 5. It appears that the second *hunebed* of Uelsen-Steenebarg was not examined. Furthermore, it is far from certain that one of these two *hunebedden* is the megalithic tomb discovered by Visch in 1819. The location of the remains that were discovered by Schlicht are more accurately described as ‘near Uelsen’ than between ‘Uelsen and Getelo’.

The nearest *hunebedden* appear to be the three destroyed sites near Nordlohne, *Gem.* Wietmarschen, *Kr.* Gr. Bentheim (Fansa, 1984), lying some 30 km distant to the east, but these belong in fact to the much larger group of megalithic tombs between Lingen and Rheine, which are mostly on the east side of the river Ems (see the distribution maps of megalithic graves in Schlicht (1979) and Günther (1970)). The reason for the isolated situation of Mander O2 and the two *hunebedden* of Getelo-Uelsen becomes clear if we

look at the map of the higher lying and for the TRB more important sandy areas which Bakker (1976: fig. 6) has compiled. Northern Twente is separated from Drenthe on one side and from the Hümmling and the Ems area on the other by lowlying wet and probably at that time already partly peat covered areas. Connections with Drenthe must have been via the valley of the Vecht. The most westerly extension of the ice-pushed ridge of Itterbeck-Uelsen-Ootmarsum stretched almost to the Vecht. Communication was easier towards Westphalia.

In addition to the *hunebedden* we can also look at flat graves. In this, Mander also appears as to be fairly isolated. The only other flat grave that we know of in Twente is Denekamp-Klokkenberg with Late Havelte pottery (Bakker & Van der Waals, 1973). In addition to this, in 1991, the Twente Oudheidkamer was presented with a funnel beaker which had been discovered in the 1960s near Denekamp and which undoubtedly came from a flat grave (Verlinde, 1992).

About 4 km north of Mander O2, Schlicht excavated the remains of a flat grave near Uelsen which had been discovered by children when they found sherds of pottery and a complete pot together with some field stones. The pots were a pail and amphora of early Horizon 4. The stones were described as coming from a cobbled floor, but were probably rows of stones which supported the coffin as was found in Mander. An interesting aspect is that Schlicht found the two destroyed Uelsen-Steeneberg sites as a result of this discovery (Schlicht, 1963; 1967).

The nearest flat grave cemetery is at Baalder Es, northeast of Hardenberg, about 21 km northwest of Mander-O2. This cemetery was dug away in 1937 when the *es* was excavated for sand in order to fill in ancient Vecht meanders. A retired school teacher from Hardenberg collected the finds for the *Vereeniging Overijsselsch Regt en Geschiedenis* which, thanks to a system of rewards for the labourers, was very successful but he forgot unfortunately to record where the different artefacts/objects were found. In total, 35 pots were found, 6 polished axes and about 25 pieces of worked flint in an area with a diameter of about 20 metres (Ter Kuile, 1938; Knöll, 1959: tables 41 and 42). The pottery belongs mainly to Horizon 4. Further away, about 30 km, are the flat graves of Dalen-Huidbergsveld (Kooi, Delger & Klaassens, 1989), while the flat grave cemetery of Heek (Averbeck I and II, Ammerter Mark, see Finke, 1983: *Neujahrgruss Münster* 1987: pp. 30–32 and 1988: pp. 26–28) are about 40 km distant from Mander, just as the small flat grave cemetery of Zuidwolde (Van Giffen, 1937; Bakker, 1979: pp. 187–188 and figs B16 and B17).

The extent to which the isolated position of Mander-O2 and the *hunebedden* of Uelsen-Getelo had an effect on the local development of the decoration of the pottery cannot be established here. Ufkes (1993) indicated that she could distinguish something of this, but without adequate drawings of the pottery from O2 and from the *hunebed* of Uelsen-Steeneberg excavated by Schlicht it is difficult to check this. The second author would have liked to have examined the pottery from both *hunebedden* and to have compared the material with her better known Drentse TRB pottery. It has not yet been possible to establish the present location for the finds from Uelsen-Steeneberg, let alone arrange for the material to be loaned for examination!

6. REFERENCES

- BAKKER, J.A., 1976. On the possibility of reconstructing roads from the TRB period. *Berichten van de Rijksdienst voor het Oudheidkundig Bodemonderzoek* 26, pp. 63–91.
- BAKKER, J.A., 1977/78. Nordwestdeutsche Megalithgräber in niederländischen. *Berichten des 17. bis 19. Jahrhunderts. Die Kunde* NF 28/29, pp. 21–31.
- BAKKER, J.A., 1979. *The TRB West Group*. Amsterdam, Subfaculteit der Pre- en Protohistorie.
- BAKKER, J.A., 1988. A list of the extant and formerly present *hunebedden* in the Netherlands. *Palaeohistoria* 30, pp. 63–72.
- BAKKER, J.A., 1992. *The Dutch hunebedden*. Ann Arbor, International Monographs in Prehistory.
- BAKKER, J.A. & J.D. VAN DER WAALS, 1973. Denekamp-Angelslo. Cremations, collared flasks and a Corded Ware sherd in Dutch final TRB contexts. In: G. Daniel & P. Kjaerum (eds) *Megalithic graves and ritual*. Moesgård, Jutland Archaeological Society, pp. 17–50.
- BENTHEM Gz, A., 1920. *Geschiedenis van Enschede en zijne naaste omgeving*. Enschede, Van der Loeff. Tweede druk.
- BERG, M.W. VAN DEN & C. DEN OTTER, 1982. Geology and morphology of a part of the Ootmarsum ice-pushed ridge. *Palaeohistoria* 24, pp. 35–40.
- BRINDLEY, A.L., 1986. The typochronology of TRB West Group pottery. *Palaeohistoria* 28, pp. 93–132.
- BRINDLEY, A.L., J.N. LANTING & A.D. NEVES ESPINHA 2001/2002. Hunebed D6^a near Tynaarlo. *Palaeohistoria* 43/44, pp. 43–85.
- BIJLANDT, GRAAF F. VAN, 1839. Verslag van een uitstapje naar de Heriker Bergen. *Overijsselsche Almanak voor Oudheid en Letteren* 5, pp. 145–153.
- DINGELDEIN, W.H., 1964. *Het land van de Dinkel*. Amersfoort, Roelofs van Goor. Vierde druk, verzorgd door Dr. C.C.W.J. Hijzeler.

- FANSA, M., 1984. Wiederentdeckung und Untersuchung eines Grosssteingrabes in Nordlohne, Gemeinde Wietmarschen, Ldkr. Grafschaft Bentheim. *Archäologische Mitteilungen aus Nordwestdeutschland* 7, pp. 1–9.
- FINKE, W., 1983. Ein Flachgräberfeld der Trichterbecherkultur bei Heek, Kr. Borken. *Ausgrabungen und Funde in Westfalen-Lippe* 1, pp. 27–32.
- GANGELEN, H. VAN & K. HELFRICH, 1992.. De keramiekvondsten vanaf circa 1550. In: P.H. Broekhuizen *et al* (eds) *Van boerenref tot bibliotheek*. Groningen, Stichting Monument & Materiaal, pp. 293–345.
- GIFFEN, A.E. VAN, 1925/27. *De hunebedden in Nederland*. Utrecht, Oosthoek. Twee tekstdelen + Atlas.
- GIFFEN, A.E. VAN, 1937. Een grafveld uit de hunebeddientijd op de ‘Ekel(en)berg’ bij Kerkenbosch, gem. Zuidwolde. *Nieuwe Drentse Volksalmanak* 55, pp. 71–74.
- GIFFEN, A.E. VAN, 1943. Het Ndl. hunebed (D XXVIII) te Buinen, gem. Borger. *Nieuwe Drentse Volksalmanak* 61, pp. 115–136.
- GÜNTHER, K., 1970. *Steinzeit und Ältere Bronzezeit im Landesmuseum für Vor- und Frühgeschichte Münster*. Münster, Landesmuseum für Vor- und Frühgeschichte.
- GIJN, A.L. VAN, 2002. Het vuursteen uit het hunebed van Mander. In: A.D. Verlinde (ed.), *Archeologische Kroniek van Overijssel over 2001*, *Overijsselse Historische Bijdragen* 117, pp. 225–253, spec. pp. 229–232.
- HUISKES, B., 1985. Van veldnaam tot vindplaats? Een onderzoek naar het verband tussen hunebedden en ‘steennamen’ in Drenthe. *Driemaandelijke bladen voor taal en volksleven in het oosten van Nederland* 37, pp. 81–94.
- HUISMAN, H. & W.A.B. VAN DER SANDEN, 2003. Kolossale steenen’ onder het veen. Het vermeende hunebed van Nieuw-Dordrecht. *Nieuwe Drentse Volksalmanak* 120, pp. 129–137.
- HIJSZELER, C.C.J.W., 1966. Mander en omgeving, gem. Tubbergen. *Verslagen en Mededelingen van de Vereeniging tot Boefening van Overijsselsch Regt en Geschiedenis*, 81, pp. 1–50.
- HIJSZELER, C.C.J.W., 1970. De pre- en protohistorie van Twente. In: B.H. Slicher van Bath *et al* (eds), *Geschiedenis van Overijssel*. Deventer, Kluwer, pp. 37–50.
- HIJSZELER, C.C.J.W., 1980. De oudheidkundige onderzoekingen in Twente in de loop der tijden. *‘t Inschrien* 12, pp. 63–67.
- HIJSZELER, C.C.J.W., 1981. Graven in historie In: H. Schelhaas & B. Molenaar (eds), *Graven en begraven in Overijssel* (serie: Jaarboeken Overijssel). Zwolle, Waanders, pp. 19–37.
- KNÖLL, H., 1959. *Die nordwestdeutsche Tiefstichkeramik und ihre Stellung im nord- und mitteleuropäischen Neolithikum*. Münster, Aschendorff.
- KOOI, P.B., G. DELGER & K. KLAASSENS, 1989. Vlakgraven en grafheuvels op het Huidbergsveld bij Dalen (Dr.) *Paleo-Aktueel* 1, pp. 40–44.
- KUILE, G.J. TER, 1938. De praehistorische vondsten te Hardenberg 1937. *Verslagen en mededelingen van de Vereeniging tot Boefening van Overijssels Regt en Geschiedenis* 54, pp. 7–17.
- LANTING, J.N. & A.D. VERLINDE, 1996. Heropgraving hunebed Mander, 38 jaar later. *‘t Inschrien* 28, pp. 42–47.
- PEETERS, H., 1986. *Hunebed O2 – Mander*, inventarisatie van het lithisch materiaal. Intern rapport IPP, Amsterdam.
- SCHLICHT, E., 1956. Steingraber in der Grafschaft. Gedanken zu den Ausgrabungen bei Uelsen. *Das Bentheimer Land* 46 (= Jahrbuch des Heimatvereins der Grafschaft Bentheim 1956), pp. 84–89.
- SCHLICHT, E., 1957. Die Untersuchung eines zerstörten Steingrabes bei Uelsen. *Das Bentheimer Land* 47 (= Jahrbuch des Heimatvereins der Grafschaft Bentheim 1957), pp. 15–23.
- SCHLICHT, E., 1963. Ein Flachgrab der jüngeren Steinzeit bei Uelsen. *Das Bentheimer Land* 55 (= Jahrbuch des Heimatvereins der Grafschaft Bentheim 1963), pp. 103–106.
- SCHLICHT, E., 1967. Drei nichtmegalithische Gräber der Trichterbecherkultur im Emsland. *Die Kunde* NF 18, pp. 16–29.
- SCHLICHT, E., 1979. Die Grosssteingraber in nordwestlichen Niedersachsen. In: H. Schirinig (ed.), *Grosssteingraber in Niedersachsen*. Hildesheim, Lax, pp. 43–58.
- SPECHT, H., 1935. Das Geheimnis des ‘Steenebarges’ bei Uelsen. *Das Bentheimer Land* 11, p. 72.
- SPROCKHOFF, E., 1975. *Atlas der Megalithgräber Deutschlands Teil 3: Niedersachsen-Westfalen*. Bonn, Habelt.
- STAPERT, D., 1982. A Middle Palaeolithic artefact scatter, and a few younger finds, from near Mander NW of Ootmarsum (province of Overijssel, the Netherlands). *Palaeohistoria* 24, pp. 1–33.
- STROINK, L.A., 1962. *Stad en land van Twente*. Hengelo, Smit.
- UFKES, A., 1992. De inventaris van het hunebed O2 te Mander (Ov.). Doctoraalscriptie Prehistorie, Groningen.
- UFKES, A., 1993. Het hunebed O2 bij Mander (Ov.). *Paleo-Akteel* 4 pp. 31–32.
- VERLINDE, A.D., 1992. Archeologische kroniek van Overijssel over 1991. *Overijsselse Historische Bijdragen* 107, pp. 172–205 spec. pp. 177–179.
- VERLINDE, A.D., 1995/1996. Het voormalige hunebed van Mander: plannen en problemen. *Jaarboekje Historische Kring Vasse Mander Hezingen*, pp. 23–26.
- VERSFELT, H.J., 2003. *De Hottinger-atlas van Noord- en Oost-Nederland 1773–1794*. Groningen, Heveskes.
- VISCH, W.F., 1820. *Geschiedenis van het graafschap Bentheim*. Zwolle, Zeehuisen.

APPENDIX

After the 1995 excavation a finds list was compiled in Amersfoort, based on the information on the finds labels and notes on the field drawings. As already indicated in the main text this compilation contains some mistakes which can be corrected, however, with the help of the information in the excavation diary by the first author. The corrected list is given below. The finds are kept in the *Oudheidkamer Twente* in Enschede, unless stated otherwise.

1. C. 10 TRB-sherds, from faintly coloured soil trace.
2. C. 20 TRB-sherds, from faintly coloured soil trace.
3. C. 200 TRB-sherds, from large, invisible pit (Feature A).
4. Decorated TRB-bowl, from Feature A.
5. Undecorated bowl, from invisible pit (Feature B), together with 6.
6. Small undecorated bowl from Feature B, together with 5.
7. Fragments of granite, from extraction pit/foundation pit of eastern endstone of former *hunebed*.
8. Decorated tureen-amphora, from flat grave/ Feature C.
9. Four red-baked, partly glazed sherds of 16th century pottery, found in E-W running boundary ditch, east of *hunebed*.
10. Small undecorated bowl, from Feature E, together with 11 and 12.
11. Small decorated tureen-amphora, from Feature E, together with 10 and 12.
12. Decorated amphora type 2, from Feature E, together with 10 and 11.
13. TRB-sherds and some pieces of flint, found in the filling of the cart track south of Feature E.
To this number belong the undecorated sherds and pieces of flint now numbered 16, and the large unnumbered fragment of a decorated Horizon 3–4 bowl (see fig. 20), but not the small undecorated bowl, now numbered 13.
14. Stones from flat grave/Feature F (present whereabouts unknown).
15. Decorated tureen-amphora from flat grave/Feature F.
16. Small, undecorated bowl (40% plaster), wrongly numbered 13 at the present. Found in flat grave/Feature G together with 17, 18, 19 and 20.
17. Decorated tureen-amphora, from flat grave/Feature G together with 16, 18, 19 and 20.
18. Small, decorated tureen-amphora, from flat grave/Feature G, together with 16, 17, 19 and 20.
19. Undecorated amphora type 2, from flat grave/Feature G, together with 16, 17, 18 and 20.
20. Undecorated collared flask, from flat grave/Feature G, together with 16, 17, 18 and 20.
21. Sample of charcoal-rich soil in filling of flat grave/Feature G.
22. Decorated funnel beaker, from flat grave/Feature H.
23. Undecorated bowl, from flat grave/Feature I.

24. Eighteen TRB-sherds, recovered during cleaning of excavation surface.
- 25–32 Stones, from flat grave/Feature G.
33. Large wall fragment of sharply carinated pot found close to 34 under the cart tracks between Features E and J.
34. Half of an undecorated bowl, found close to 33.
35. Flint axe from flat grave/Feature J, together with 39, 40 and 41.
36. 35 TRB-sherds and some pieces of stone and flint. In the Amersfoort finds list wrongly attributed to flat grave/Feature J. Probably recovered during cleaning the excavation surface near this Feature.
37. Undecorated bowl, from flat grave/Feature K, together with 38. The Amersfoort finds list mentions a flint flake, as well.
38. Undecorated bowl with inwards turning rim, from flat grave/ Feature K, together with 37.
39. Transverse flint arrowhead, from flat grave/Feature J, together with 35, 40 and 41.
40. Nine flint flakes found together in flat grave/Feature J, with 35, 39 and 41. Three of the flakes fit and belong to the top of a polished flint axe.
41. Large decorated bowl, from flat grave/Feature J, together with 35, 39 and 40.